

COMPUTATIONAL ANALYSIS FOR INDUSTRIAL BRUSH WITH DISCRETE ELEMENT METHOD

Vu Anh Tuan¹, Luong Phu Khanh², Nguyen Huu Hien³, Nguyen Hong Duong⁴,
and Nguyen Thi Phuong Mai⁵

School of Mechanical Engineering, Hanoi University of Science and Technology, Hanoi, Vietnam,

e-mail: gundamomega@gmail.com ¹,
email: hiennguyen.wil@gmail.com ²,
e-mail: phukhanhbk11@yahoo.com.vn ³,
e-mail: nguyenhongduong.hut@gmail.com ⁴,
e-mail: maintp-mcx@mail.hut.edu.vn ⁵

Received Date: July 23, 2012

Abstract

In this study, the discrete element computational method (DEM) is applied to analyze the dynamic problems of an industrial cup brush in cleaning process. At first, the method was created in order to analyze the flows of granular materials, and then it has been developed to be able to model more complex objects like rods or beams of brittle, elastic or composite materials. The recently designed flexible rod model in this research is composed of spherical particles linked together to form an elastic rod-type object. Theoretical model and the simulation model will be expressed to draw out the result as the total slipped length of the brush, the total contact area, and acting forces between rod tips and surfaces in comparison with different rotary speeds. The analyzed results show that the slipped distance of a brush on surfaces and forces between brush tips and surfaces increase when the rotary speed is increased, while the total contact area are smallest at a certain rotary speed of 450 rpm, and this total area is larger when either increasing or decreasing the rotary speed. Hence the most effective cleaning speed in the current research is 900 rpm. It is possible to simulate and evaluate several different types of brushes to find the best model and compatible parameters for surface cleaning and polishing process by applying the DEM flexible rod model.

Keywords: Cleaning process, Discrete element method, Industrial brush

Introduction

Nowadays, industrial brushes play an important role in mechanical processes of surface treatment. The basic structure of industrial brushes contains multiple filaments implanted on a holder. While moving beyond a surface, the resilience of the filaments continuously causes many contacting forces which is the main factor in deburring, cleaning and polishing processes. There are many types of surface treatment in response to the purpose of usage and the characteristics of the surface. Corresponding to them, there are also many kinds of brushes with various shapes, size and materials. Each type of surface and brush has been used with reasonable purpose in particular industrial process. Since dust may affect the perceived air quality of the supply air and cause problems to the occupants [1], the ability of brush should be estimated by simulation before being applied in real life.

However, in order to improve and optimize surface treating activities, it is necessary to understand clearly the process. In surface treating process, the dynamic behaviors of filaments on holders are quite complex because of multiple interactions among filaments and their large deformation, especially that large deformation causes nonlinearity bending

of filaments on the brush. Until now, there are some programs that have been developed to simulate similar cleaning processes [1], [6], [7], [8], [9]. In one experiment using finite element method (FEM), the rotational speed, tilt angle and frictional conditions have significant effects on brush characteristics [9]. However, they are not sufficient in calculating exactly the deformation of each filament, the length of way which filaments scratch on the surface, and the forces acting on filaments. Another characteristic that has not been covered is the total contact area, which is important to evaluate cleaning ability of the brush because of the complexity of non-linear deformation, multiple interactions between filament-filament and between filament-surface. In this case, discrete element method (DEM) has an advantage to solve multiple contacts matter which is still inappropriate in current stimulations using FEM and other numerical simulations. In order to simulate behavior of filaments in surface treating process, a flexible rod model (FR) is developed by connecting many particles based on DEM. The brush model is built with multiple rods which fixed at one end like a cantilever beam. The behavior of filaments in cleaning process is simulated by dynamic behavior of multiple cantilever beams under loading using large deformation elastic theory [1]. The physical phenomena of filament-surface and filament-filament interaction will be considered like particle-particle and particle-wall interaction with the equations described in DEM theory and the particle interactions in each rod is calculated by equations of the FR model.

Finally, using DEM technique and FR model, the behavior of rods in surface cleaning is simulated. The working parameters of rods which affect the cleaning ability of the brush such as total slipped length of rods which sweep on surface, normal forces, tangential forces, and total contact areas will be studied clearly in this paper. Additionally, the total slipped length and total contact area are very essential parameters in evaluating the effectiveness of the brush in the cleaning process. Based on the information from the simulations and further researches, real models with efficient operating parameters can be developed to apply in suitable industries.

Theoretical Model

Flexible Rod Model

The flexible rod model (FR) is composed of a series circular particles linked together to form a rod. The deformation of a rod is due to the forces acting on the intra-rod particles. A linear damped spring is used to model the force between intra-rod particle centers. The total deformation of one rod is calculated from the superposition of the following forces and moments.

The elongation restoring force due to the elongation of the beam is given by [4]:

$$\vec{F}_j^{\text{elong}} = -EA\Delta L \quad (1)$$

where E is the Young modulus, A is the cross section, $\Delta L = (|r_{ij}| - L)/L$, with L is the initial length and r_{ij} is the current length between linked particles.

The bending force Q and bending moment M^z are calculated from the change in the orientation of the connected particles, in different planes [4]:

$$\vec{Q}_j^z = 3EI \frac{(\theta_i^z + \theta_j^z)}{L^2} \mathbf{e}_y \quad (2)$$

$$\vec{M}_j^z = EI \frac{(\theta_i^z - \theta_j^z)}{L} \mathbf{e}_z + (\vec{Q} \times \vec{r}_{ij}) \mathbf{e}_x \quad (3)$$

The torsion M^{tor} due to relative rotation around the particle – to – particle (x axis) [4]:

$$\vec{M}_j^{\text{tor}} = -GI^{\text{tor}} \frac{(\theta_j^z - \theta_i^z)}{L} \mathbf{e}_x \quad (4)$$

Where: e_x, e_y, e_z are the unit vectors of the coordinate system, I is moment of inertia, G is modulus of rigidity, I^{tor} is moment of inertia of the particles linked for torsion, θ_i and θ_j are the orientations corresponding to the two particles.

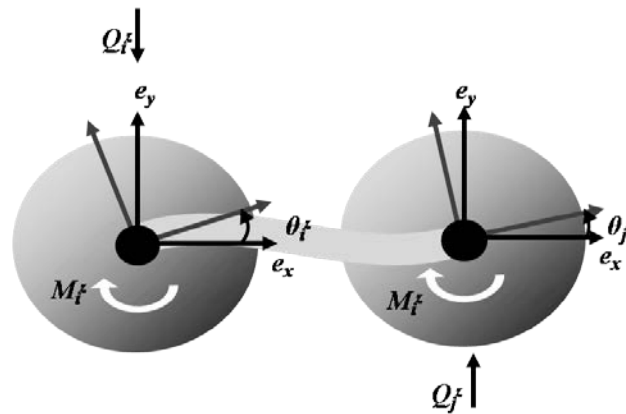

Figure 1. Forces and torques on intra-rod particles

Discrete Element Contacting Model

The chosen model is the dashpot – spring model [2], [3], [5] for all external contacts: between particle – particle (outer contacts of unconnected particles) and particle – surface. The contact model for normal contact force includes a spring and a damper; while in case of tangential contact force, there are a spring and a damper in series with a frictional sliding element.

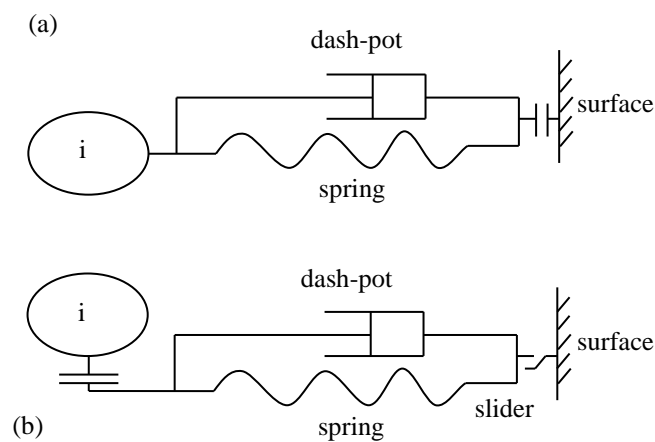

Figure 2. Contact model between particle (i) – fixed planar surface for : normal force (a) and tangential force (b) This model is also used for outer particle – particle contact

The normal and tangential contact force acting on a particle i in a particle - surface contact can be calculated as followed [2], [3], and similar equations are also applied in particle - particle contact case:

$$\mathbf{F}_{\text{normal},i} = (-k_n \delta_n + v_n \Delta \mathbf{v}_{\text{contact}} \cdot \hat{\mathbf{n}}) \cdot \hat{\mathbf{n}} \quad (5)$$

$$\mathbf{F}_{\text{ta.ngent},i} = \min \left\{ k_s \delta_s + v_s \Delta \mathbf{v}_{\text{contact}} \cdot \hat{\mathbf{s}} ; \mu_s \left| \mathbf{F}_{\text{normal},i} \right| \right\} \cdot \hat{\mathbf{s}} \quad (6)$$

Where:

- k_n, k_s : normal and tangential spring constants,
- δ_n, δ_s : normal overlap and tangential displacement,
- v_n, v_s : normal and tangential damping coefficients,
- μ_s : tangential sliding friction coefficient.
- $\Delta \mathbf{v}_{\text{contact}}$: relative velocity
- $\hat{\mathbf{n}}, \hat{\mathbf{s}}$: normal and tangential unit vectors

Discrete Element Model in Simulation

In the simulation program, a cup brush model [10], is created by multiple rods implanted on the cup-type holder. The rods are made from brass 70-30 C2600, a quite soft material that can be used in light deburring, cleaning and polishing surfaces. Normally, the brush has a large number of filaments twisted into tufts which are mounted into the cup. To reduce the simulation time, we design a smaller and simpler model, which has only 36 rods of diameter 0.89mm. They are distributed evenly in circles, and concentric with the cup holder. The diameters for the circles are 5.34mm (inner) and 6.23mm (outer), in order to ensure that 1 rod of the inner circle and 2 rods on the outer circle form a group similar to a tuft of filaments. Each rod is created from 10 particles, and each particle has a diameter of 0.89mm, and 2 particles at one end are fixed on the holder. Currently the real runtime for this model is around 10 hours for 1s of simulation time.



Figure 3. Small cup brush model (left) and real cup brush (right)

The rods of the brush are modeled using large deformation elastic theory [1]. The elastic modulus, E , Poisson ratio, ν , density, ρ are the associated properties defined parametrically. In addition, certain simplifying assumptions are made and these are described more accurately in the reference [1], [9]. First, the rod is considered to obey elastic rod theory so that the deformations are due to the bending moment and normal force, while the deformations due to shearing force are neglected. Second, the contact forces are assumed to act on the central axis of the rod tip. Third, the process is in dry condition, so there are only additional gravity force and air drag force. Fourth, all forces and moments are calculated based on mechanical properties, so any effects of heat or electromagnetic forces are neglected.

The modeling specially consists of generating the contact pairs for rod - rod and rod - surface of work piece. In this study, the work piece is an ultra thin parallel hand - twin cylinder part, HLD-08CS-T2H-D [11] (Figure 4). In a brushing system, the rods tend to undergo large deformations and the surface tends to deform at a micro scale. The physical phenomena of rod - surface and rod - rod interaction is considered as particle - particle and particle - fixed surface interaction [5], and the connected particles interaction in each rod is calculated by equations (1) to (4) of the FR model.

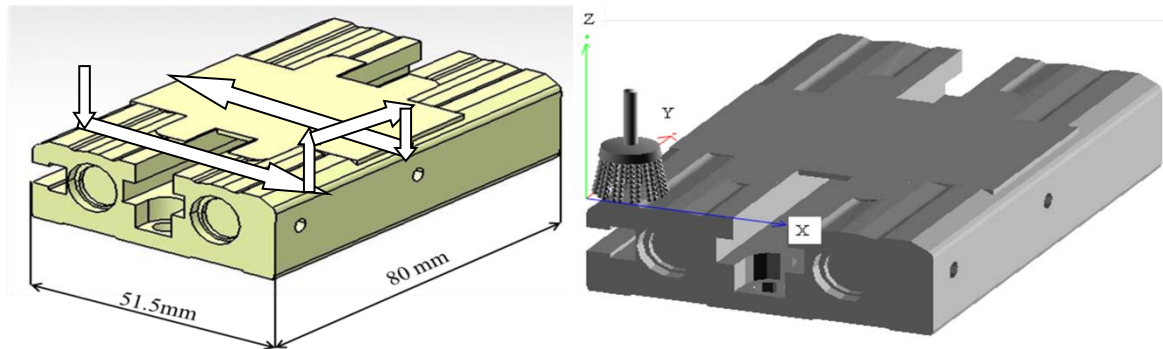

Figure 4. Surface of twin cylinder work piece with brush trajectory (left) and visualized simulation of cleaning process (right)

The materials used for brush and work piece in the simulations are brass and steel, respectively. The properties of these materials are described fully in Table 1, while other parameters for the brush simulations are described in Table 2. During the whole process, the brush only contacts with the upper surface of the twin cylinder, as shown in Figure 4. The cleaning process is separated in 2 parts, and the trajectory is represented by the white arrows in Figure 4.

In the first part, the brush moves down slowly onto the bumpy part of the surface at a corner until the work piece penetrate about 1mm into the brush, then the brush moves horizontally to the other side along the surface width to clean it, and is quickly pulled up at the side end. In the second part, the brush moves to the middle of the long side of the surface, then it moves down slowly to the surface again, and then moves horizontally back to the previous side. The vertical feed rate is 0.01m/s, the horizontal line speed is 0.15m/s, and the rotary speeds of the holder are 300 rpm, 450 rpm, 600 rpm, 750 rpm and 900 rpm.

The units for all quantities in the simulation such as forces, torques, lengths, and areas are SI units. The original sample rate at which the results are printed out is 10.000 instants per second.

Table 1. Material Properties

Material	Brass	Steel	Unit
Elastic Modulus	110	200	GPA
Density	8530	7930	kg/m ³
Poisson's ratio	0.331	0.31	
Coefficient of friction	Brass	0.07	0.44
	Steel	0.44	

Table 2. A Summary of the Parameters Used in Cup Brush Simulations

Parameter Name	Symbol	Value	Unit
Number of particle in each rod	N_p	10	
Number of rods	N_f	36	
Trim length of each rod	L_f	8.9	mm
Inner Diameter	D_{in}	5.34	mm
Rod mount angle	ϕ	10	degree
Diameter of each particle/rod	d	0.89	mm
Width of surface	W	51.5	mm
Line speed	v_x	0.15	m/s
Rotary speed	ω_z	300, 450, 600, 750, 900	rpm
Vertical feed rate	v_z	0.01	m/s
Simulation time step	Δt	39.8	ns

Simulation Results & Discussions

In order to evaluate the cleaning ability of a brush, the parameters such as total slipped length, normal force, tangential force, overlapping area between rods and work piece surface will be investigated, with different rotary speeds and only when the brush is moving horizontally across the surface (one time on the bumpy area, one time on the flat area).

Total Slipped Length

The total slipped length is an important parameter to evaluate the cleaning ability of the brush. It is defined as the total slipping distance occurred in a single rod – surface contact due to tangential forces, and thus can be used to define the work of friction forces. Normally, when the surface is planar, the slipped value is constantly increased because the non-contact phenomena do not occur. However, there are always burrs, holes, or cavities on a machined surface. Therefore, the brush is programmed to run on the bumpy part once and the smooth part of the same work piece model once to study the differences between the rod – surface interactions of these periods.

The total slipped length is calculated for the whole process (Figure 5). Two important time intervals are from 0.121s to 0.404s, when the brush is cleaning the bumpy part of the surface, and from 0.671s to 0.954s, when the brush is cleaning the flat part of the surface.

Firstly, the figure shows that the slipped distances gradually increase during the cleaning intervals, and the slopes seem to be linear in the later interval. The deviations between the slipped lengths increase significantly in the first interval, then level off, and continue to increase in the next interval. At the end of the first interval and the end of the whole process, the values of the total slipped lengths for the slowest speed of 300 rpm and the fastest of 900 rpm are at the ratio of 0.627 and 0.637, respectively. This ratio just slightly increases and it shows that the changes in rotary speed may affect the slipped distances when cleaning a flat surface as much as it does when cleaning a rough surface in this case. Moreover, the values of the slipped lengths increase while raising the rotary speed of the brush, as higher rotary speed helps the brush covers greater length within the same time interval.

In brief, the higher the rotary speed is, the greater the slipped length is, and the deviations do not change much between cleaning a totally flat surface or a rough surface. As a result, the cleaning efficiency of the brush may increase on a surface if the rotary speed is raised.

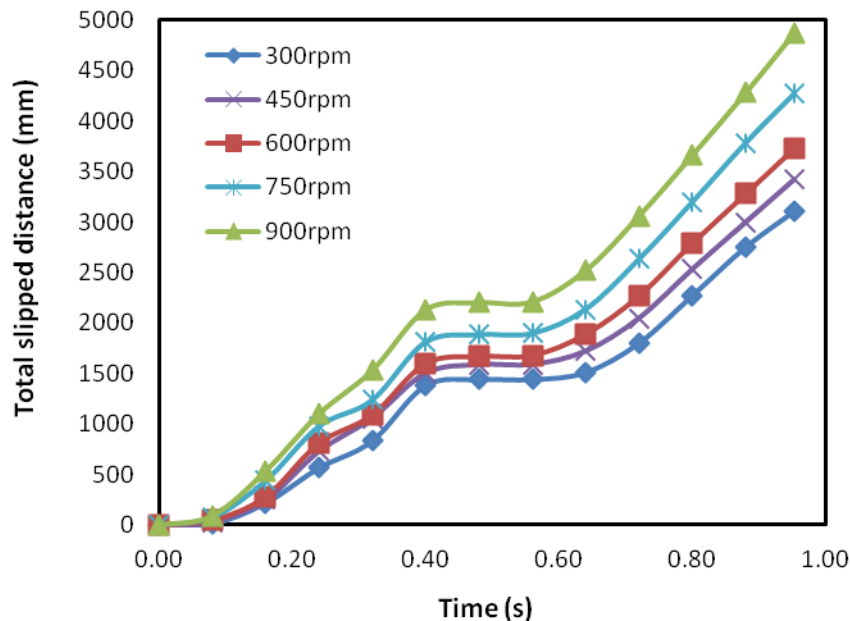

Figure 5. Total slipped distance between brush rods and work piece for the whole process

Total Contact Area

The contact area is calculated from the deformation of the particle, which is based on the overlapping between the particle and the surface. It is important since the larger it is, the more efficient the cleaning is. In this case the total contact area is given by the sum of individual contact areas between each rod and the surface in each time step. The slope of this total area also shows the total magnitudes of the normal forces that press the brush onto the surface, as the more the particles overlap with the surface, the larger these forces are.

The total contact areas are calculated for the whole process, in the same way as the total slipped distance (Figure 6). Two important time intervals are also from 0.121s to 0.404s and from 0.671s to 0.954s, when the brush is sweeping horizontally to clean the work piece.

The graphs for the total contact areas are much more complex than the total slipped distance, as the particles experienced random contacts and deformation during the process, especially on a rough surface. Overall, the total overlap area in most cases has a more stable and steep rise in the second contact interval than in the first interval. This phenomenon may be because the rods contacts with the surfaces more evenly, although the pressing forces may be smaller. It shows that the cup brush works more efficiently on a level surface.

The figure shows that the largest total area at the end of the first interval is covered at the speed of 300 rpm, while the largest total contact area for the whole process is swept at the speed of 900 rpm. In most cases, the total contact area goes up to around 6000 mm², only at the speed of 450 rpm, the brush covers a much smaller, at around only 4000 mm². Even though in the first cleaning interval, the total area is much larger at 450 rpm than at 600 rpm, but in the second interval, the total area at the speed of 600 rpm rises much faster. Hence, the cleaning efficiency of the brush seems to be lower at the rotary speed of 450 rpm. For this work piece, the efficiency seems to be highest when the brush operates at 900 rpm.

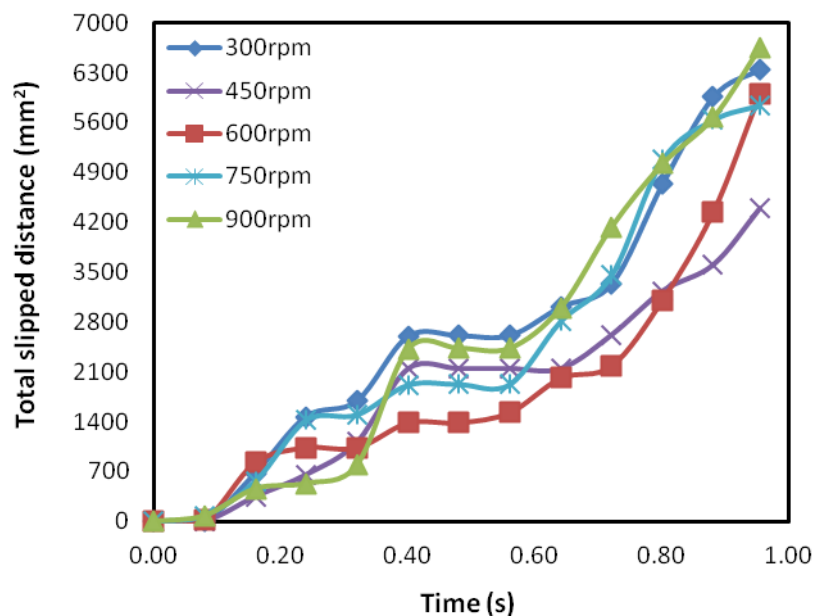

Figure 6. Total contact areas between brush rods and work piece for the whole process

Contour Plot for Normal and Tangential Forces Acting on Rod Tips

In a cleaning process, the rods impinge upon the contaminant and remove it from the surface. The total force acting on a rod tip, delivered in this manner, is divided into two components, one is tangential and the other is normal to the surface. The tangential force is the force that works to remove the contaminant from the surface. The normal force actually works to drive the contaminant into the surface, and also increases the sliding tangential friction. Besides that the normal force causes the rod to bend during the process.

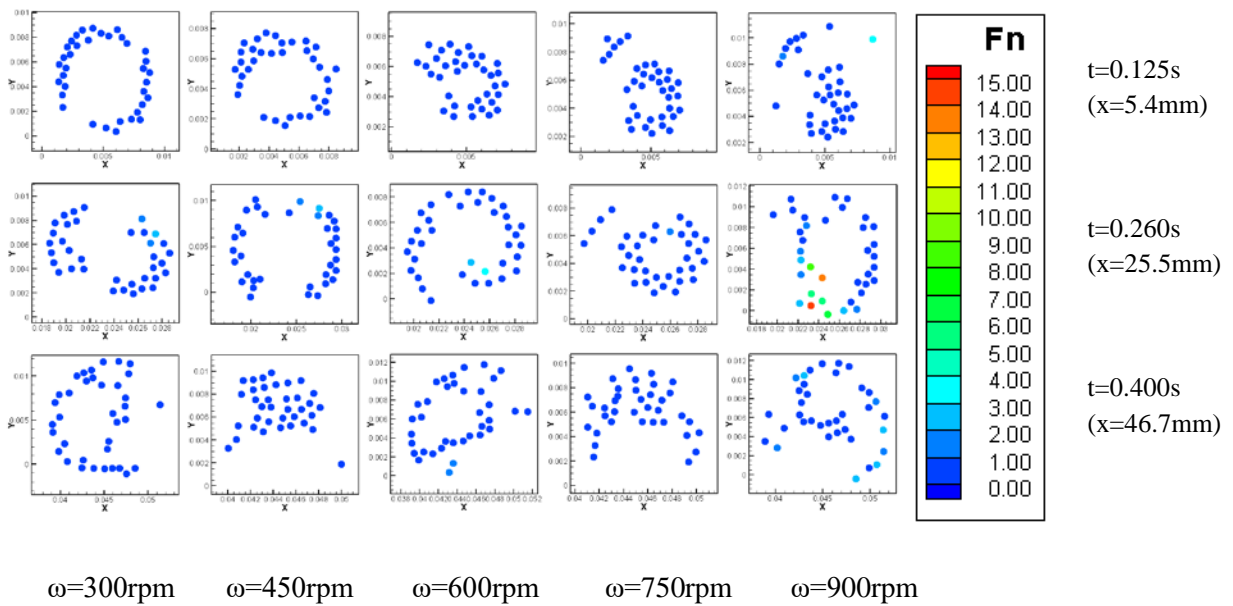

Figure 7. Contour plot of normal forces on brush tips

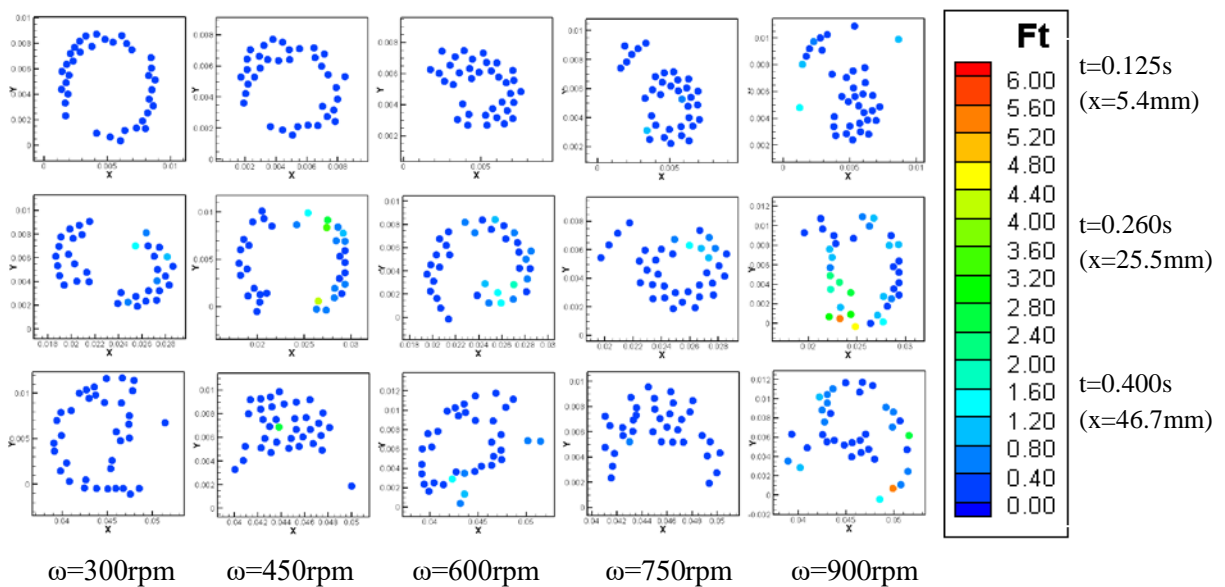

Figure 8. Contour plot of tangential forces on brush tips

The forces are investigated only in the first time interval from 0.121s to 0.404s at 3 time instants: at 0.125s, when the brush starts moving horizontally and interacts with the first groove, at 0.260s, when the brush is at the middle of the bumpy part of the work piece where the brush tips hit the vertical sides of the middle hole, and at 0.4s when the brush is passing the last groove to finish the horizontal path.

The contour plot shows that the normal force and tangential force range from 0 to nearly 15N and 0 to nearly 6N respectively. The forces seem to be smallest at 300rpm, and greatest at 900rpm, at each instant. Comparing the 3 instants, the forces are much greater when the brush is at the middle of the surface, this might be because its rod tips hit the sides of the hole at high speed. In most cases, greater forces are distributed at the right side

(higher x value) and front side (lower y value) of the brush. This may cause uneven cleaning result on the surface, and thus the brush may have to operate on a return path instead of a one-way run.

To sum up, the forces are greatest when the cup brush rotates at the speed of 900 rpm, so this can be the most effective operation speed, but the forces differ a lot at different position which may affect the cleaning efficiency of a one-way operation. Large forces may also result in damaging the work piece.

Conclusions

The discrete element computational method was introduced and applied to dynamic problems of granular materials. In order to simulate the deformation and dynamic of long shaped structures, the flexible rod model has been developed and applied to the analysis of dynamic problems such as the behavior of a cup brush filaments to study the parameters and conditions which affect its cleaning ability. The changes of simulation parameters, such as the rotary speed and the shape of the surface in this research, has showed that the cleaning effectiveness of the cup brush type, which is estimated via several parameters including the total slipped length, the total contact area and the interacting forces, can be improved by increasing the rotary speed and operating on a more level surface. Moreover, although the total slipped length simply increases while raising the rotary speed, the total contact area after the whole process may reduce at a certain speed that is 450rpm for the current simulation setup, which means that there should be a certain operation speed range that we should avoid. The results also show that the forces in the brush rods – surface interaction are not evenly distributed at higher speeds, thus there should be a two-way cleaning operation instead of a one-way run.

These simulations show that the flexible rod model of the DE method is able to predict the dynamic characteristics of brush rods in surface cleaning process. By applying flexible rod model of DEM, we can simulate and evaluate different types of brush model by changing certain input parameters, and it is possible to choose the most proper set of parameters and conditions for the most efficient and effective cleaning.

REFERENCE

- [1] R. Holopainen, and E.-M. Salonen, "Modelling the cleaning performance of rotating brush induct cleaning," *Energy and Buildings*, Vol. 34, No.8, pp. 845–852, 2002.
- [2] P.A. Cundall, and O.D.L. Strack, "A discrete numerical model for granular assemblies," *Geotechnique*, Vol. 29, No. 1, pp. 47-65, 1979.
- [3] D.S. Boyalakuntla, *Simulation of Granular and Gas-Solid Flows Using Discrete Element Method*, Carnegie Mellon University, 2003.
- [4] F.K. Wittel, H.A. Carmona, F. Kun, and H.J. Herrmann, "Mechanisms in impact fragmentation," *International Journal of Fracture*, pp. 154:105-117, 2008.
- [5] T. Pöschel, and T. Schwager, *Computational granular dynamics: Models and algorithms*, Springer-Verlag, Berlin, 2005.
- [6] L.V. Vannegas-Useche, M.M. Abdel-Wahab, and G.A. Parker, "Dynamic finite element model of oscillatory brushes," *Finite Elements in Analysis and Design*, Vol. 47, pp. 771–783, 2011.
- [7] L.V. Vannegas-Useche, M.M. Abdel-Wahab, and G.A. Parker, "Dynamics of an unconstrained oscillatory flicking brush for road sweeping," *Journal of Sound and Vibration*, Vol. 307, pp.778-801, 2007.

- [8] L.V. Vannegas-Useche, M.M. Abdel-Wahab, and G.A. Parker, “Dynamics of a freely rotating cutting brush subjected to variable speed,” *International Journal of Mechanical Sciences*, Vol. 50, pp. 804–816, 2008.
- [9] M. Abdel Wahab, G. Parker, and C. Wang, “Modelling rotary sweeping brushes and analyzing brush characteristic using finite element method,” *Finite Elements in Analysis and Design*, Vol. 43, pp. 521–532, 2007.
- [10] *Tanis Brush Catalogs* [Catalogue], [Online]. Available: <http://www.tanisbrush.com> [Accessed: Jan 2012]
- [11] CKD Company, *Catalog No.CC-925* [Catalogue], 2011.
- [12] “*Engineer’s Handbook*” (n.d.) [Online]. Available: <http://engineershandbook.com> [Accessed: Feb 2012]