

ANALYSIS OF RWANDA'S GRID POINT OF STABILITY LOSS

Silas Bizimungu^{a*}, Francis Njoka^b, Churchill Saoko^{a, c}, Clement Siame^d

^aInstitute of Energy and Environmental Technology, Jomo Kenyatta University of Agriculture and Technology. P. O. Box 62000 – 00200, Nairobi, Kenya

^bDepartment of Energy Technology, Kenyatta University. P. O. Box 43844 – 00100, Nairobi, Kenya

^cDepartment of Physics, Jomo Kenyatta University of Agriculture and Technology. P. O. Box 62000 – 00200, Nairobi, Kenya

^dTransmission Department, ZESCO. P. O Box 33304, Lusaka, Zambia

Article history

Received

19 April 2022

Received in revised form

01 January 2023

Accepted

04 February 2023

Published online

31 August 2023

*Corresponding author

silasb@ieee.org

Graphical abstract

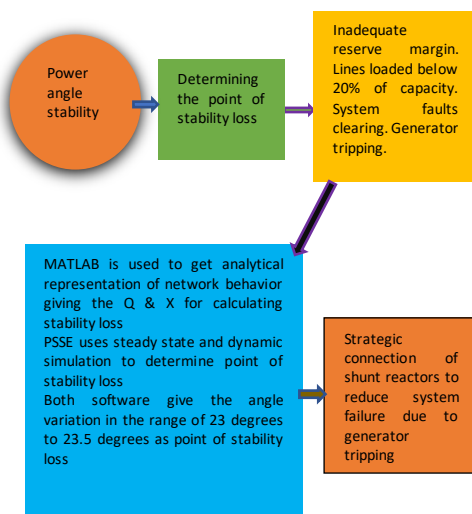

Abstract

Electricity stability is the key component in ensuring reliable power supply which is a major hurdle in most developing countries. Power angle being part of grid stability pillars, this work sought to theoretically and numerically investigate the maximum power angle variation that the power system in Rwanda could experience while maintaining transient stability at an acceptable range beyond which generators lose synchronism affecting overall system stability. A steady state and dynamic stability assessment of the lightly loaded Rwandan grid is conducted using PSS/E while MATLAB is used to obtain input values for calculating the system stability power angle. This involved collecting actual network parameters, creating an accurate model of the entire Rwandan grid and validating the model simulation results using regularly metered values at various critical busbars of the network. Results from the study show that a sudden drop in load of 11 MW and 6 MVar leads to a variation of power angle of the largest power plant by 23° triggering transient stability problems leading to loss of synchronism. Both calculated and simulation results show that, a sudden power angle variation of between 23° to 23.5° at the swing bus power plant, causes the monitored generating units to trip triggering a long-term instability. This was done while also interrogating possible mitigation measures based on the developed and validated model. Based on the system status, the study revealed that the grid point of stability can be determined through simulation using software and to further obtain optimum stability, installation of active devices such as shunt reactors helps the grid to counter sudden variation of power angle due to line and load tripping.

Keywords: Power angle, System stability, lightly loaded, Voltage, dynamic simulation.

© 2023 Penerbit UTM Press. All rights reserved

1.0 INTRODUCTION

In present day times, power systems are operated much closer to their stability limits due to economic and environmental constraints [1]. The operating conditions of a power system should be always stable, meeting the desired operational criteria. It should also be secure in the event of any contingency [2] [3]. The transfer of power through a transmission network and their affiliated transient stability are however, naturally influenced by the power angle variations [4] due to sudden load change, system faults and switching of transmission lines. Under

normal operating conditions, the power angle varies in such a way that the grid elements and applicable parameters remain intact, hence system operators do not recognize such small variations [5] [6]. When a system experiences a sudden disturbance, a new point of stability must be attained failure to which triggers loss of synchronism of generators [7].

In the case of Rwanda, the grid operates with almost no reserve margin, most lines are loaded at only about 20% of their capacity. This makes the grid susceptible to transient stability problems especially power angle deviations. This presents a major challenge to the grid operator in ensuring that the

generating units remain in synchronism at the occurrence of disturbance to strengthen stability [8]. Power angle instability is one of the major threats to system operation in the Rwandan grid, regularly causing generator tripping in a system that is also ridden with generation deficit. With generator instability being one of the major causes of blackouts during system faults, it is important to determine the point at which this happens in a particular network because system strength or inertia differs from one grid to another. As the power angle variation greatly determines stability limits of a grid connected to it and vice versa, knowing these parameters and analyzing them would give an overview of grid behavior and provide for planned system improvements.

The case of Rwanda, unlike many other electricity grids, presents a unique opportunity to determine power angle's point of instability and interrogate appropriate strategies that can be adopted to smooth out and/or minimize such instability problems. This research work sought to numerically and through simulations determine the magnitude of power angle variation that the Rwandan grid can experience while keeping generators synchronized. From the preliminary findings, the developed model is then used to explore a possible trajectory that can be adopted to assure a stable grid in the future.

Data correction of the Rwandan electricity grid parameters was done to the detail. MATLAB is used to obtain values of X , Q and θ used in calculating grid instability point with PSS/E used to model and simulate different scenarios that led to determining point of system stability loss.

2.0 THEORETICAL APPROACH

2.1. Grid Network Setup And Behavior

An electricity grid setup is for purpose of power generation by different generation plants being transmitted and distributed to consumers, often over long distances [9]. It is appropriate to ensure that grid setup takes into account reliability, stability and security. The stability and security of a system are time-varying attributes, which can be judged by studying the performance of the power system under a particular set of conditions. When a system is subjected to a disturbance, whether transmission lines are tripped or not, generators connected to the grid are adversely affected [10]. They may even end up losing synchronism in case the resulting oscillations are not dampened, a phenomenon that results into cascaded loss of generating units in systems with low inertia.

2.2. Simplification of the Grid network

To provide a theoretical analysis while building base for the grid stability simulations, the Rwandan grid is reduced into a single generator of infinite rating, a single line with loads lumped at one substation and connected to the equivalent large generator through a transmission line as shown in an equivalent diagram in figure 1. This was developed considering an equivalent synchronous machine from the network source impedance at Kibuye power plant substation that was taken to be connected to an infinite bus through a transmission line of reactance X (assuming that the resistance and capacitance are negligible) to Shango substation shown in figure 1.

The study is based on an off-peak light loading case of 74.5 MW. The simplification was done based on equivalent parameters of the machines and the lines based on the system source impedances. The reduced network is obtained assuming ideal operating conditions and used to further simulate stability status. Since a network never operates in ideal conditions as it is dynamic in nature, the simulations were hence done under different scenarios.

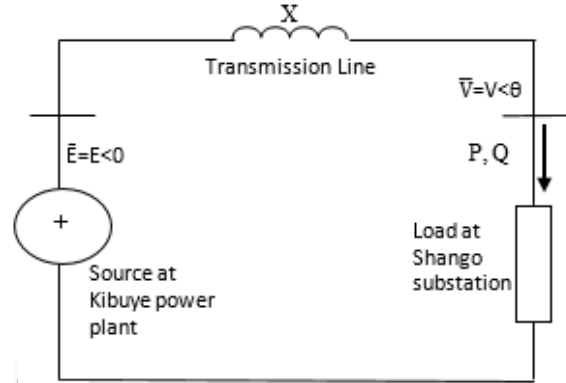

Figure 1: Grid equivalent circuit

From figure 1, E is the source voltage, X the line reactance, V is the load bus voltage, θ is the phase angle difference between the load and the generator buses, P is the active power and Q is the reactive power consumed by the load.

Under balanced three-phase, steady-state sinusoidal conditions, system operation is described by the power flow or load flow as in equations 1 and 2 [11] [12].

$$P = \frac{EV}{X} \sin\theta \quad (1)$$

$$Q = \frac{V^2}{X} + \frac{EV}{X} \cos\theta \quad (2)$$

Solving (1) and (2) with respect to V yields;

$$V = \sqrt{\left[\frac{E^2}{2} + QX \pm \sqrt{\left[\frac{E^4}{4} - X^2 P^2 - XQE^2 \right]} \right]}$$

Assuming a lossless line, V will be equal to E , hence;

$$P = \frac{V^2}{X} \sin\theta \quad (4)$$

$$V = \sqrt{\frac{PX}{\sin\theta}} \quad (5)$$

$$Q = \frac{V^2}{X} + \frac{V^2}{X} \cos\theta \quad (6)$$

$$V = \sqrt{\frac{QX}{1+\cos\theta}} \quad (7)$$

With an ideal case, equation 4 shows that the power angle is dependent on loading, reactance and voltage whereas equation 5 and 7 show that voltage level along an AC transmission line is mainly influenced by the capacitive charging and the loading of the line [13] [14].

2.3 Power Angle Stability

The focus of system stability is the interchange of power between generators/machines in the system acting to keep themselves in step with each other and to maintain a single universal frequency [15], hence retaining equilibrium between mechanical power input and electrical power output through adjustment of system voltage levels and the common system frequency [16] [17].

If the power system is subjected to a disturbance that does not lead to net change in power, machines can easily return to their original state. However, if such a disturbance causes an unbalance between the supply and demand, a new operating state is inevitable and could cause power angle oscillations above and beyond the generating unit capacity to damp [18]. The oscillations are reflected as fluctuations in generation and the power flow depending on the initial operating condition of the system that include the generator capability, line loading and the extent of the impact to which it is subjected.

The single unit generator is taken to be connected to infinite power system as shown in figure 1, with the infinite busbar taken to maintain a constant terminal voltage, frequency and can absorb all the active and reactive power output of the generators.

However, practically, voltage is not infinite, but changes with change in load, network conditions and generation hence resulting in adjustment in generation response. The power system is characterized by significant changes in synchronous generator performance, so that the transition from one to another steady operating condition is often accompanied by significant changes in the dynamic power angle.

Taking the system equivalent circuit shown in figure 1 to analyze the load angular displacement of the generator's rotor in response to system conditions [19] and representing the voltage phasors of the system power grid bus bar voltage at different intervals, the corresponding phasor diagram is shown in figure 2.

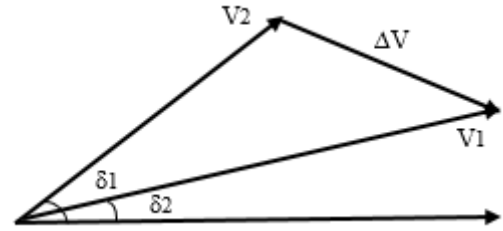

Figure 2: Voltage phasor diagram

Where V_1 is voltage before disturbance, V_2 is voltage after, δ_1 and δ_2 are angles corresponding to V_1 and V_2 , respectively. The angle, δ being the transition between the two states is equivalent to $\delta_1 - \delta_2$.

Using equation 1 and 2, the active power and reactive power at bus 1 are given by;

$$P = \frac{V_1 V_2 \sin \delta}{X_L} \quad (8)$$

$$Q = \frac{V_1 (V_1 - V_2 \cos \delta)}{X_L} \quad (9)$$

Equations 8 and 9 indicate that the active and reactive power flow can be regulated by controlling the voltages, angle, and line impedance of the transmission system.

Whereas the variation of these parameters due to a disturbance or tripping of a major load in a system leads to power angle variation, in practice generators operate with a small angle to keep the system stable from the transient and dynamic oscillations [20]. The stability of generators is highly dependent on status/stability of transmission lines linking these generating units to system loads. Hence, as the active and reactive power flow and fluctuation affect stability of transmission lines, the tolerable power fluctuation depends on the initial operating conditions of the grid such as the line loading and nature of the disturbance [21].

3.0 SOLUTION PROCEDURES

3.1. Grid Off-Peak Loading Status

The Rwandan grid model was built based on light loading characterized, on average, by a 77.2 MW of off-peak generation and a 74.5 MW of off-peak load [22]. Considering the thermal rating of transmission lines under study verses off-peak system load, the 110 kV sub-system loading is considered to be very lightly loaded. Each transmission line has power transfer limits and Surge Impedance Loading (SIL) that must be referred to for stable system operation. These limits depend on the thermal resistance of the line, the voltage limits, and the stability limits of the network. An initial verification was conducted on the Rwandan sub-system loading as shown in figure 3. Looking at the load flow on different transmission lines in figure 3, it can be deduced that almost all the 110 kV lines in the system are lightly loaded, with load percentage under 20% of their rated capacity. Such system light loading gives rise to over-voltages at busbars due to capacitive behavior of the network (Ferranti effect)

coupled with under-excitation limiters preventing generators and/or synchronous compensators from absorbing the excess reactive power beyond their capacity [23].

Having established the status of the network, a more detailed preliminary analysis of reactive power generation and consumption, and its effect on generator angle point of stability is done.

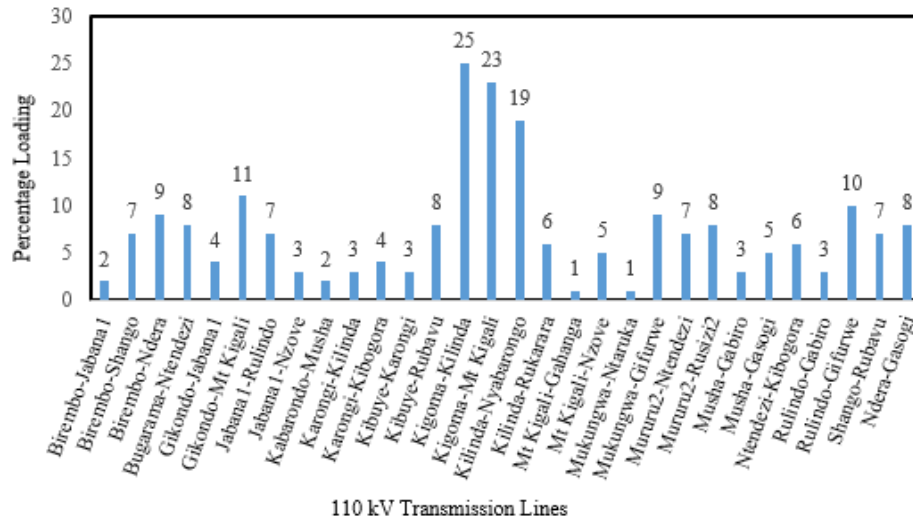

Figure 3: Loading of 110 kV lines in Off-Peak regime.

3.2. Theoretical Solution Parameters

To interrogate the situation more technically and based on the actual recorded values from Rwanda’s National Electricity Control Center, measurements of the reactive power arising from changes in *P* were taken then using the Power angle equations, the corresponding angles were calculated. Equations 4, 5 and 7 are plotted in MATLAB software using equivalent parameters of the grid presented in Table 1. All the results are in per unit values with 100 MVA as base MVA and 110 kV base voltage. The obtained equivalent values in Table 1 are used to plot power – angle, reactive power – voltage graphs.

Table 1: Grid equivalent parameters

Parameter	Value	Unit
X	0.4	Ohms
Q	0.01 to 0.07	p.u
θ	11	Degrees

The theoretical analysis of the Rwanda grid created the basis to determine power angle variation that make the Rwandan grid unstable and the need to come up with proposed remedial measures when the instability can lead to total system collapse. As experienced on the Rwandan grid, this network study is based on power angle stability as it relates to the phenomena of increased under excitation and significant changes in power angle. An important issue in this time frame is the behavior of the major generator and other generation units, and the ability of the grid to withstand the change in operating conditions.

3.3. Model Setup And Procedures

Using the updated data of 2020 from the database of the Rwandan grid, the power system master plan for 2016, substation equipment data from the planning department and measurements from the SCADA, the model was built into PSSE raw data. The actual setup of the Rwandan network (as shown in Figure 4) is such that generation is more concentrated in one zone compared to other zones [24]. Generated power is then evacuated through long transmission lines delivering it to load centers. The setup presents unique operational challenges that require modeling using engineering simulation tools to determine steady state and dynamic system behavior.

To develop a model in PSSE, data from transmission line impedances and charging admittances, busbar voltages, transformer impedances and tap ratios, admittances of shunt-connected devices such as static capacitors and reactors, load-power consumption at each bus of the system, real power output of each generator or generating plant and either voltage magnitude at each generator bus or reactive power output of each generating plant, are required. Maximum and minimum reactive power output capability of each generating plant and single line diagrams of the substations are also used as inputs to the model [25].

To simulate system behavior under different operation scenarios, parameters of the entire Rwandan network are used in setting a power system model in the working file. This comprised the 121 busbars of which 29 make up the 110 kV transmission subsystem, 34 are 30 kV distribution subsystem, 8 form 15 kV distribution sub-system and 50 forms the generation subsystem ranging from 0.4 kV to 11 kV [22]. The 110 kV subsystem being the backbone of the Rwandan network, its

loading status is of focus to fully comprehend the subsequent effect it would have on the entire grid.

To ensure that the system is balanced and converges, a power flow raw data simulation is done by solving the model in steady state mode. Dynamic system behavior is determined by simulating different scenarios including tripping of generator units, loads and transmission lines, while monitoring variation of active power, reactive power, voltages, machine angles, and

system frequency plotted from output files. The per-unit (p.u) values are then used to give representation of results in a more meaningful and correlated data. The selected base MVA is used to obtain a constant throughout the system and is 100 MVA for this case. The largest power plant in the system is set to be the swing bus to make up for the power difference between the scheduled loads and generated power due to losses in the network [26].

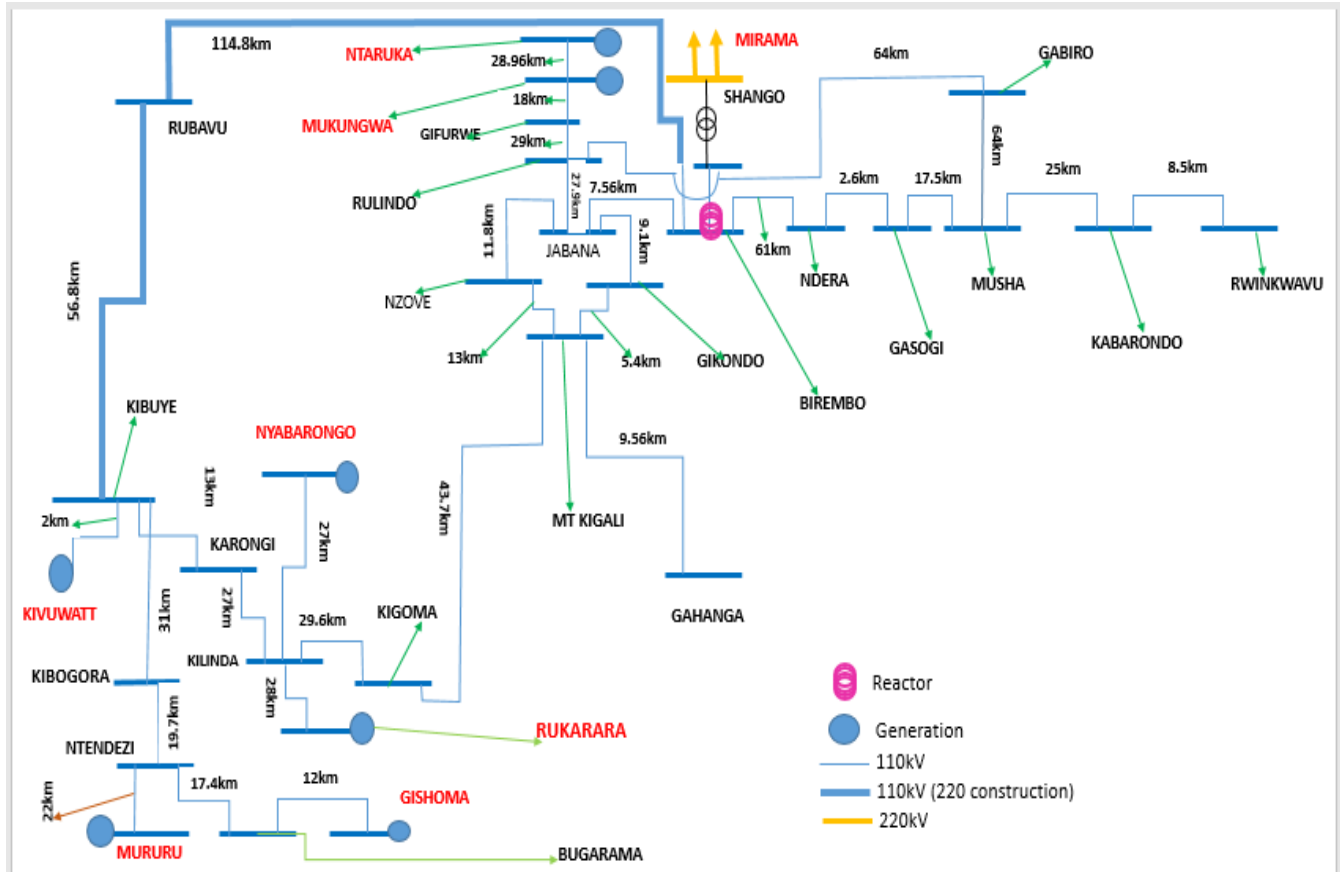

Figure 4: Rwanda's 110 kV transmission sub-system [24]

3.4. Load Flow Model Validation

The Rwandan power system is modeled based on the snapshot data obtained from the national electricity utility. After updating all relevant parameters, the off-peak model was validated to have a system model that can reasonably predict the outcome of network events. This was referenced to the real-time trends from Supervisory Control And Data Acquisition (SCADA) tool used by the utility to monitor stability status [24]. The process of model validation and "level of validity" of the model required "engineering judgment" rather than being based on a simple pass/fail of the model was determined through some rigid criteria coupled with some assumptions.

Figure 5 shows the validation process procedures for a steady state model to ensure that an accurate model is built. Different aspects of the power flow model were matched to a specific snapshot data in order to validate the network model including

Network topology (line/transformer status (on or off)), generation dispatch and transformer tap positions.

Table 2 shows the measured voltages on the 110 kV sub-system and the simulated voltages that are very close to each other with the lowest variation being -1.182% while the highest is 1.186%. The voltage was measured at different buses (presented in the table as $V_{measured}$) as obtained from Rwanda National Electricity Control Center and the calculated voltage as obtained from PSE simulation results (presented in the table as $V_{simulated}$).

The simulation and measured values of voltage further show that during off-peak periods, the grid operating voltage is beyond 119 kV on all 110 kV busbars. This implies that any tripping of a load or generator that was consuming reactive power would lead to partial or total system collapse due to cascading tripping of other grid elements.

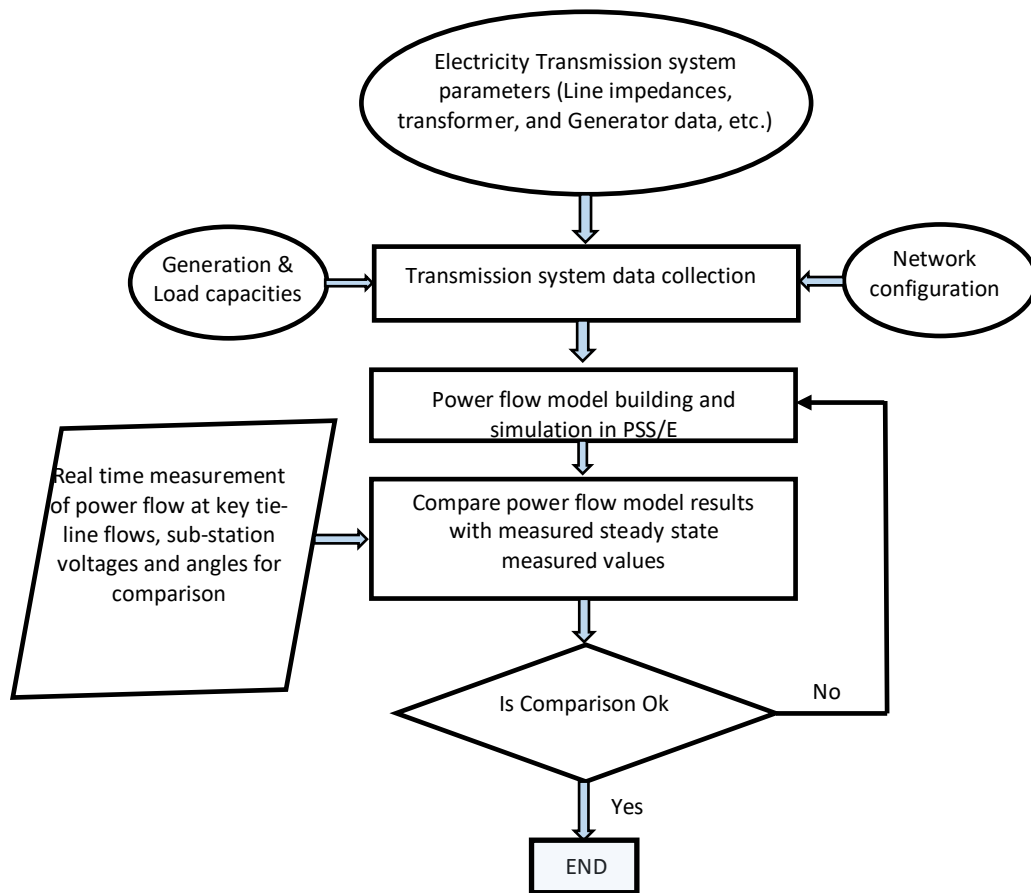

Figure 5: Model validation procedure for steady-state system conditions

Table 2: Measured and simulated voltages for the 110 kV sub-system busbars

Bus Number	Substation Name	V_{measured} (kV)	$V_{\text{simulated}}$ (kV)	Variation (%)
403121	Kigoma	120.65	119.966	0.684
403141	Mt. Kigali	120.2	120.098	0.102
403041	Gikondo	120.2	120.142	0.058
403051	Jabana	119.3	120.329	-1.029
403261	Rulindo	121.6	121.121	0.479
403001	Birembo	121.35	120.439	0.911
403191	Musha	121.1	120.681	0.419
403081	Kabarondo	120.68	120.791	-0.111
403481	Gabiro	122	121.143	0.857
403491	Ndera	121.1	120.428	0.672
403031	Gifurwe	122.17	121.627	0.543
403101	Kibogora	121.9	120.714	1.186
403091	Karongi	119.98	120.868	-0.888
403291	Rwinkwavu	121.84	120.791	1.049
403011	Bugarama	121.05	120.626	0.424
403211	Ntendezi	121	120.604	0.396
403511	Nzove	119.21	120.153	-0.943
403501	Gahanga	120.4	120.087	0.313
403231	Rukarara	119.07	120.252	-1.182

4.0 RESULTS AND DISCUSSION

4.1. Baseline System Stability Analysis

A lightly loaded system such as the Rwandan grid system, with a demand of as low as 74.5 MW during off-peak and inadequate reactive power compensation, renders its generators to consistently consume reactive power for long periods as shown in Figure 6. Such operation of power plants affects their overall transient stability.

The flow of too much reactive power in the network causes excess heating ($I^2 \cdot R$ losses) and undesirable voltage drops or

risers and loss of power along the transmission lines. Reducing reactive power could be a good grid stability ingredient. From an engineering point of view, this is so because one of the advantages of reactive power is that enough is required to control the voltage and overcome the losses in a transmission network.

Due to the capability limitations of power plants, the voltage control mechanism applied in this lightly loaded grid is neither sufficient nor reliable to control voltage as reflected in the degree of voltage violations in Figure 7.

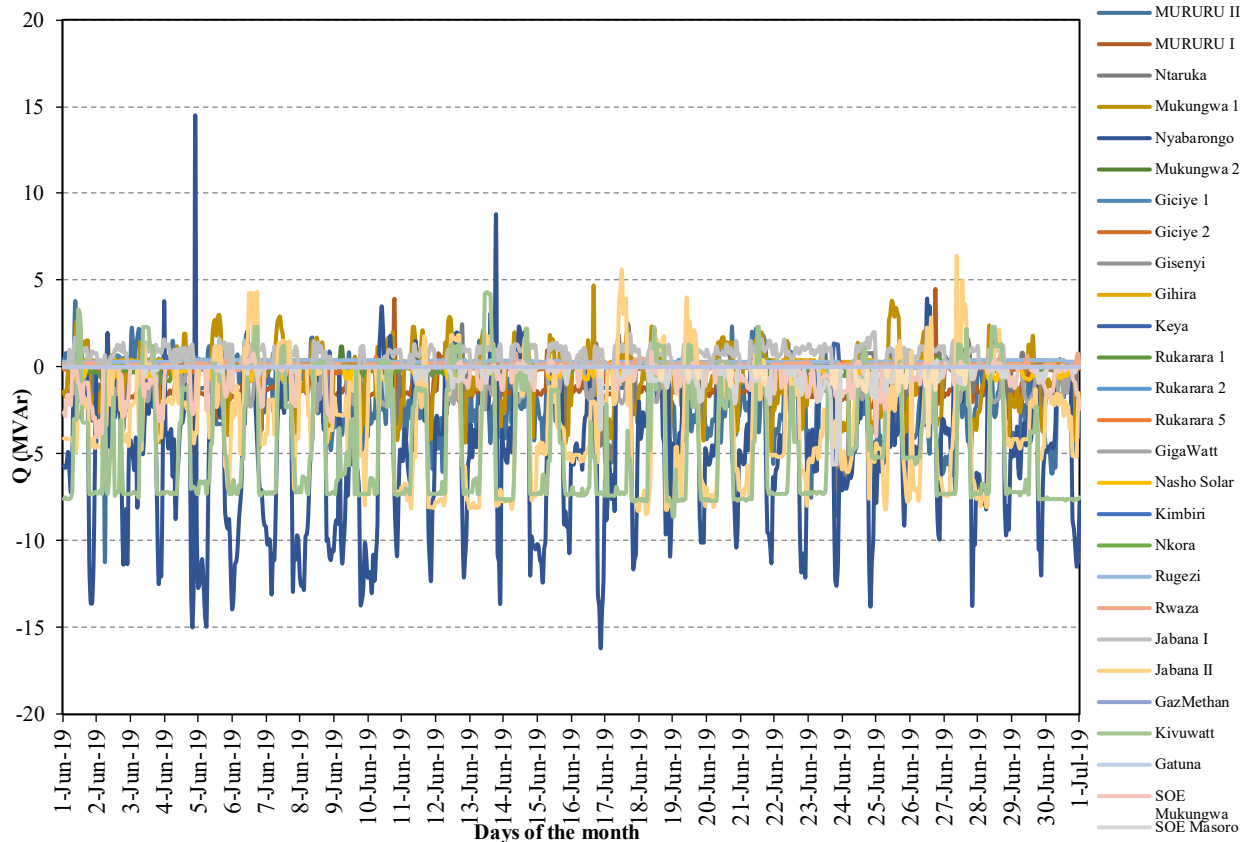

Figure 6: Reactive power generation and consumption by generating units in Rwandan system [22]

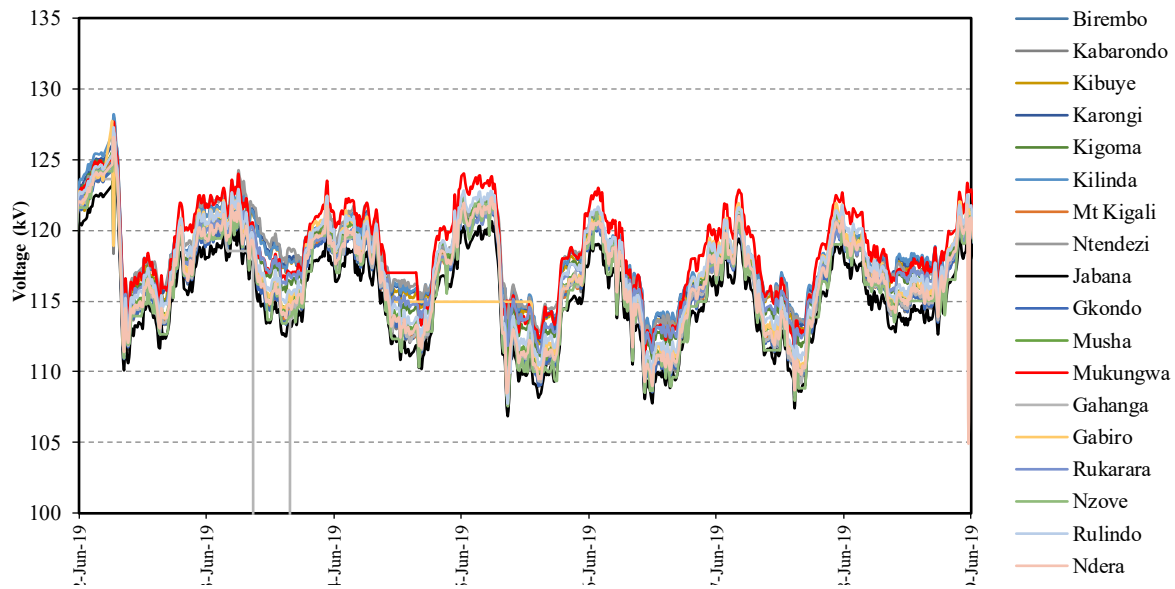

Figure 7: One week Voltage measurements on 110 kV busbars substations in the Rwandan grid

Whereas each power system is designated to operate at its nominal voltage, Figure 7 shows that voltage in such a lightly loaded uncompensated 110 kV transmission network operates way above the nominal value with instances of over 120 kV [22]. The effects of higher voltages than rated steady-state voltages results in increased stress levels in the network equipment which often leads to reduced lifespan of the equipment. Also, under light loading conditions of the network, capacitive current that emanates from transmission line charging capacitance results in excessive inductive current that flows in the system causing the voltages along the length of the line to increase. This is one of the prime causes of the network voltage instability problems triggered by the length of the line and the magnitude of the load being transmitted. This voltage deviation driven by active power and reactive power variation initiates a change that alters the system characteristics. The system is normally designed to withstand that kind of single contingency. However, under multiple independent contingencies occurring almost simultaneously in time or a completely unexpected phenomenon may violate the normal design conditions of the grid.

4.2 Grid Behaviour Analysis

The ideal cases were simulated using MATLAB codes to try and have an analytical representation of the network behaviour [27].

Figure 8 shows power-angle variation, voltage variation with system loading, and voltage variation with system reactive power taken, from Equations 4, 5 and 7 obtained using MATLAB codes.

Figure 8 (a) shows the Rotor angle stability (the angle by which a synchronous generator's rotor leads its stator field) and the angular difference between the terminals of the generator and the load. The non-linear relationship accounts for the power a

generator can transmit to its load as illustrated in figure 8 (a). The maximum power transmitted occurs at 90° and as the load lags further it becomes more difficult for the generator to support it. This Power Angle curve of a single equivalent Synchronous Machine representing the Rwandan grid is a graphical representation of electrical output with respect to the power angle from a simplified network. The power angle is also the load angle that gives a graphical representation of electrical output of the generator with respect to load angle, and was taken when delta is 11 degrees for the Rwandan light load case, giving 0.75 p.u power flow in the system. The active power transferred into the system is given along the power angle curve as shown in figure 8 (a) with the expected maximum power transferred when $\theta = 90^\circ$. As the value of load angle θ gets above 90° , active power decreases and becomes zero at $\theta = 180^\circ$. The curve is also used for steady-state limit analysis of the network. This is called the transfer reactance. The maximum power limit is inversely proportional to the transfer reactance which is the total reactance between two voltage sources E and X .

In Figure 8 (b), the voltage raise as a result of loss of load was simulated based on equation 5 from the simplified network equivalent of Rwanda grid. This showed that a loss of load could theoretically result into a voltage raise. In the theoretical plot, there are no limitation in the voltage raise as the arithmetical model could withstand higher voltages where as in reality the system cannot take such higher voltages. Figure 8 (c) then the elasticity of the grid to the change in reactive power and voltage on the Rwandan grid from a simplified model. The gradient of the graph in figure 8 (C) which is equivalent to 0.47 shows Rwanda's system ability to absorb or produce reactive power and the affiliated voltage rise or drop in the network.

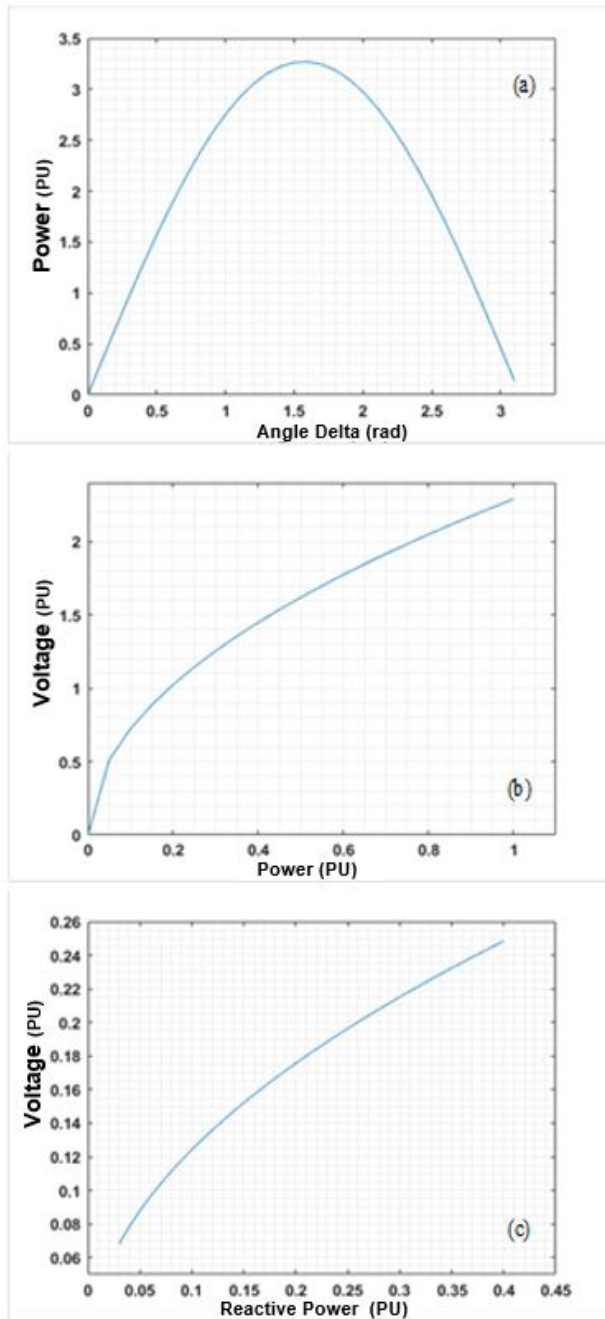

Figure 8: (a) Power Angle variation, (b) voltage increase and (c) reactive power and voltage relationship for the light loading case with 11° power angle.

4.3 Rwandan Grid Power Angle Stability Point

The power angle stability point is used here to determine such a point beyond which the generating unit power angle would adversely influence transient stability to the extent that would bring about loss of synchronism.

As the generators in Rwanda are set at 1.22 p.u at the tripping point, using equation 9, and taking a lossless equivalent network as in Figure 1, with $V_1 = V_2$,

$$Q = \frac{1.22^2(1 - \cos \delta)}{X_L}$$

Figure 8c is used to obtain reactive power corresponding to a variation of 0.22, yielding Q as 0.31 and using X_L of 0.4 obtained from the reduced Rwandan network.

Solving for δ gives 23.5°. This implies that machines in the Rwandan grid will not provide any generation at this angle.

Determining the maximum angle at which the generators trip from the system is vital in that it helps to improve the stability of the grid by ensuring system's ability to operate within the angular stability despite network conditions.

The results of the theoretical simulation and measured values oriented the study and set the basis for the network behavior analysis of the lightly loaded grid with respect to power angle. This was instrumental in the simulations using advanced software PSS/E that used network data to simulate different disturbances while enabling different adjustments on generation and/or load capacity to ascertain the system angular stability point.

4.4 PSS/E Steady State Simulation

A static simulation was done to determine system convergence and voltage status of the system. When the system converges without mismatches, then such a model is used for further analysis. The system converges with the swing bus (Nyabarongo 28 MW HPP) running at 18 MW. However, voltage at 110 kV busbars were found to be out of range with some going up to 121 kV for the off-peak regime. This concurred very well with the observed behavior from the theoretical evaluation.

Figure 9 shows the contour diagram where most sections of the 110 kV transmission lines and as reflected at various busbars, the Rwandan system experiences voltage violations exceeding 1.1 p.u (over 121 kV). This is mainly because the system is lightly loaded as shown in figure 9 without sufficient voltage compensation devices to absorb the excessive reactive power.

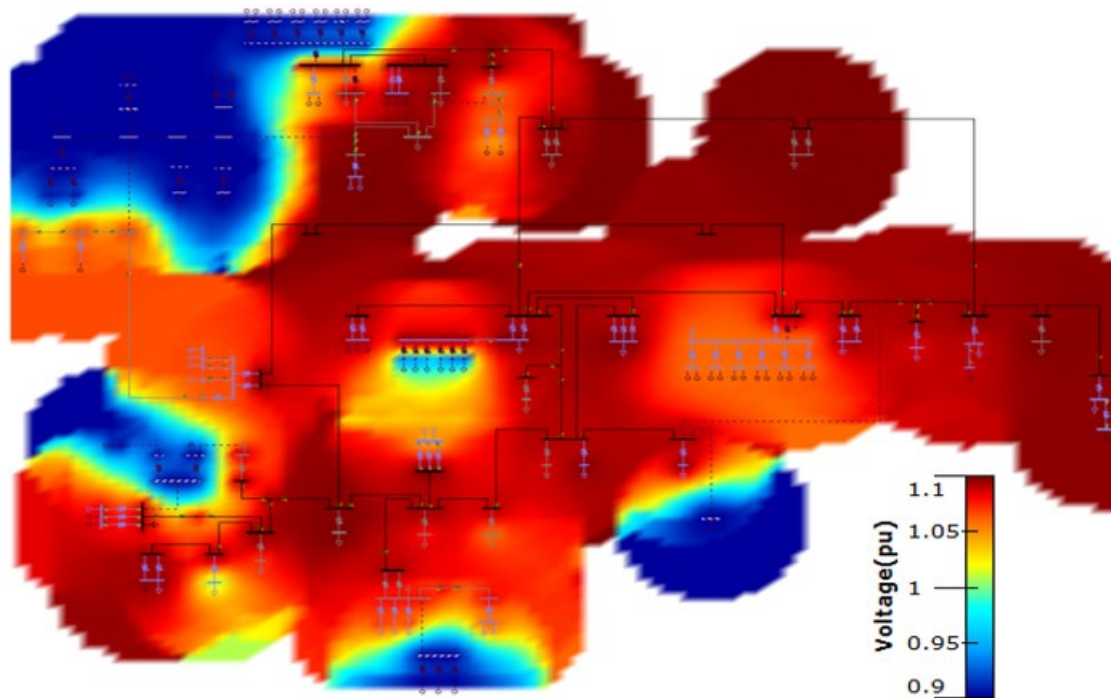

Figure 9: (Color online) Voltage contour diagram in Off-Peak regime

Figure 9 shows that whereas power plants in the Rwandan grid are utilized to control voltage by absorbing excess reactive power from the system as earlier shown in Figure 6, voltage in the entire 110 kV subsystem remains very high posing a stability challenge to power plants.

4.5 Dynamic Simulation Of Power Angle Stability

Dynamic simulation is done to determine generator operating point position with respect to power angle stability limit. This is done by tripping different load size while monitoring the behavior of the major power plant (swing bus) [28]. Various scenarios are simulated to check the ability of the Rwandan lightly loaded system to recover from single or multiple disturbances.

Angle stability being critical in maintaining the entire AC system in synchronism, its variation should be minimal that it

can be damped to attain new stability point. Whenever one generator, due to the system loading condition or fault, temporarily runs faster or slows down with respect to another generator, the angular position of its rotor, relative to that of the slower machine will advance [29]. This however is sustainable up to stability limit point that is highly dependent on initial operating conditions and system inertia [30].

Simulations are done while monitoring the biggest generating unit being Nyabarongo power plant that is also the swing bus in PSSE. This is because in PSSE, the swing bus generator serves as the stabilizing unit by reducing or increasing generation depending on load variation.

The base case dynamic simulation is done considering stable conditions of the off-peak regime. Figure 10 shows the angle behavior at largest generating unit in the system when a load is tripped at one substation.

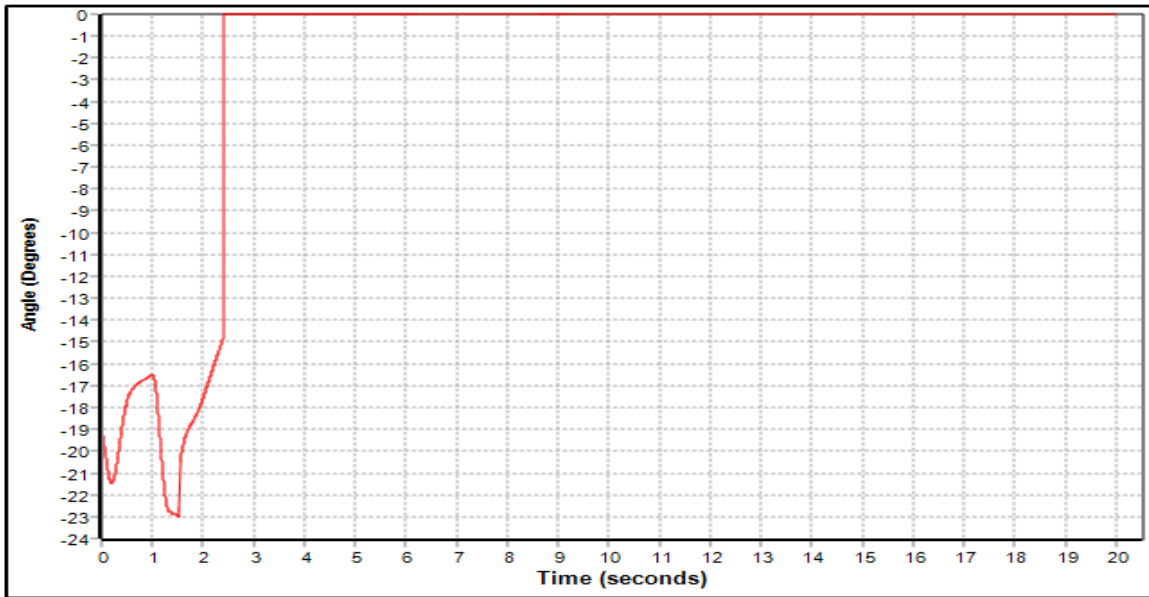

Figure 10: Power Angle at Nyabarongo power plant after tripping of an 11 MW, 6 MVAR load

It can be observed in figure 10 that when an 11 MW, 6 MVAR load is tripped in this system, the angle of the generating unit connected to the swing bus drops to 0° from 23° and does not recover. The angle variation of 23° obtained from simulation results is very close to the calculated angle of 23.5° as the angle

variation at which the machines in Rwandan grid lose stability hence stop generating any power. The plant’s mechanical power also drops to zero, an indication that the power plant tripped from the grid due to this disturbance as shown in Figure 11.

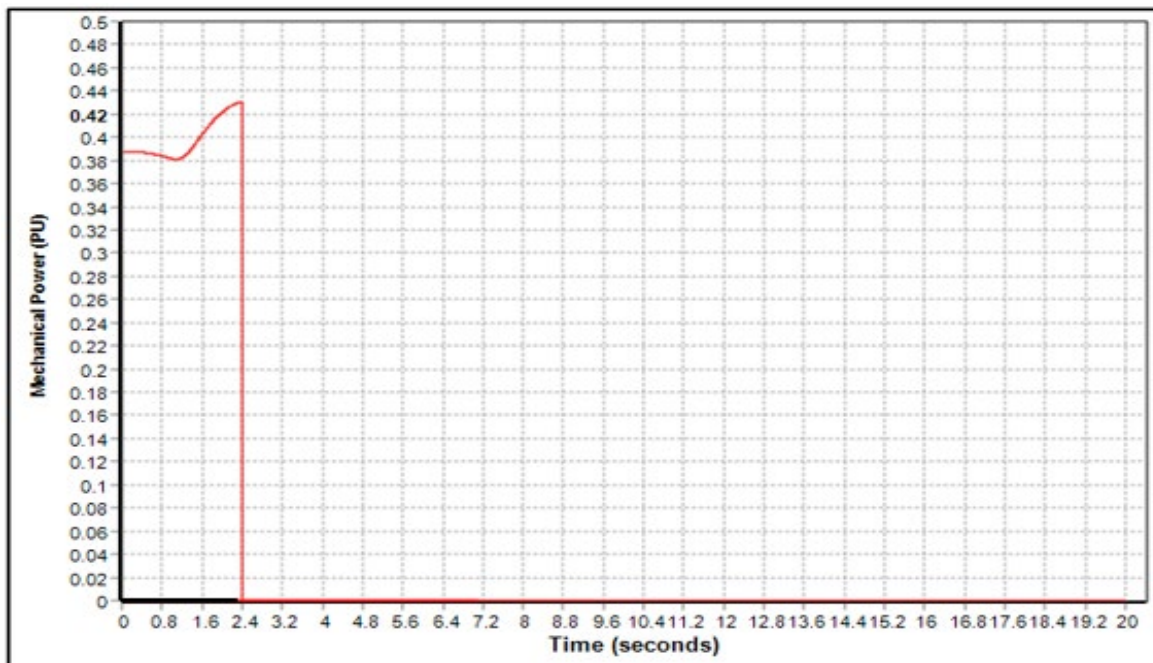

Figure 11: Mechanical Power at Nyabarongo power plant after tripping of an 11 MW, 6 MVAR load

Figure 11 further shows that mechanical power of the swing bus generating units drops to zero after $t = 2.4$ seconds, a confirmation that this generator does not produce any power when an 11 MW, 6 MVAR load is tripped in the Rwandan system. As the Rwandan grid generators operate in under-excitation state as they try to absorb the excess reactive power generated by the transmission system. This causes synchronous generators

in the system to assume the maximum allowed value in relation to the stability limit of synchronous generator operation.

4.6 Resolving Observed Stability Problems

To ensure that system instability arising from angle variation is controlled, various shunt reactors are introduced while varying

the reactive power absorption capacity up to a point of achieving stability even when the same load trips. The first scenario involved Nyabarongo power plant where tripping of an 11 MW, 6 MVAR load with a shunt reactor of 4 MVAR connected to Birembo substation 110 kV busbar was carried out. The second

simulation scenario is done with an 8 MVAR shunt reactor connected at Birembo substation 110 kV busbar and results from the two scenarios is displayed in Figure 12(a) and 12(b), respectively.

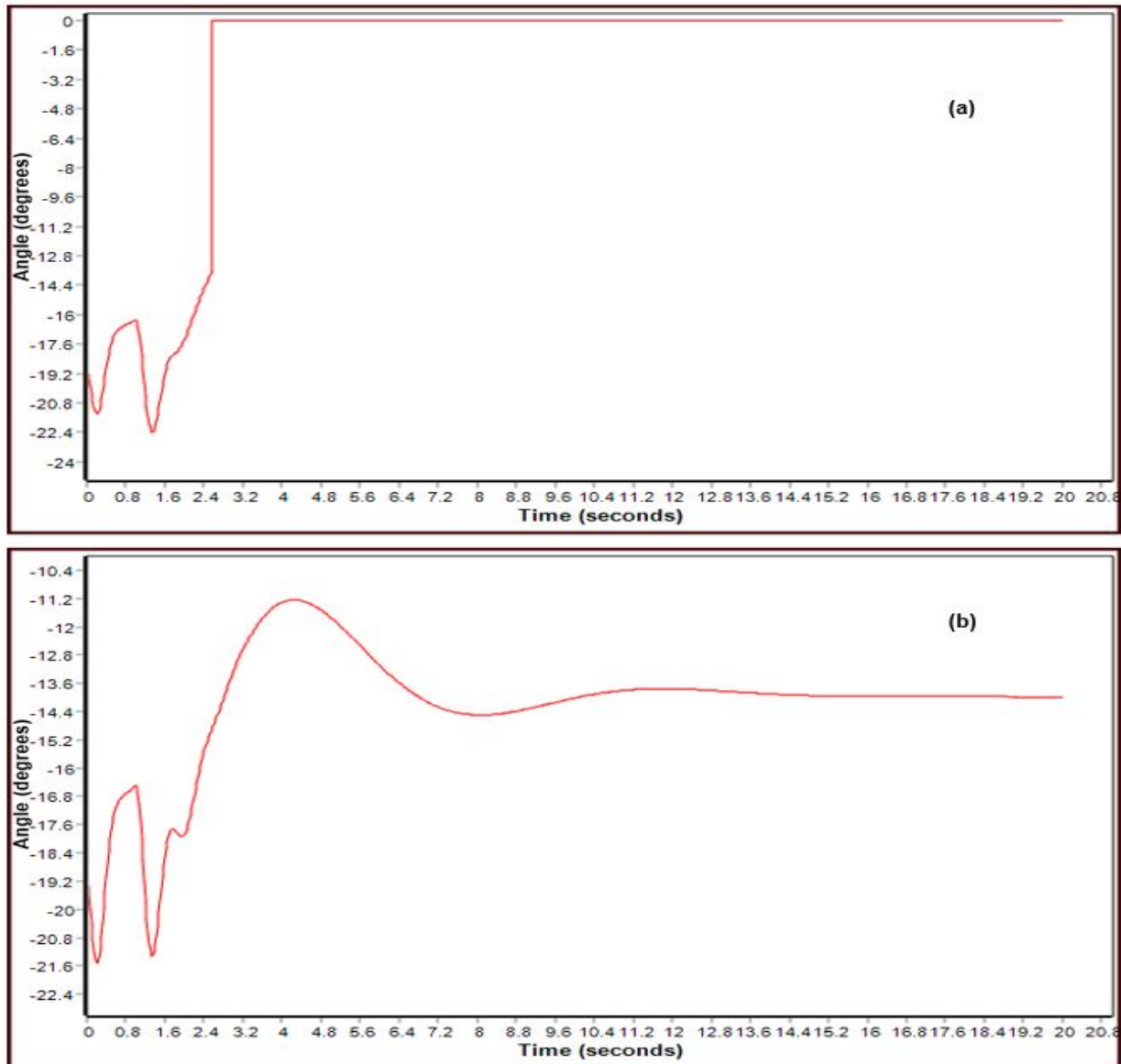

Figure 12: Power Angle at Nyabarongo power plant after tripping of an 11 MW, 6 MVAR load with a shunt reactor of (a) 4 MVAR and (b) 8 MVAR connected to Birembo substation 110 kV busbar

From Figure 12 (a) the power angle stability is affected permanently whereas (b) shows the angle of the swing bus generator remains relatively stable even after tripping of an 11 MW, 6MVAR shunt load.

Further tests were carried out and a similar behaviour was observed on mechanical power of the swing bus generators at Nyabarongo and the second largest unit at Kivu watt power plant as further shown in Figure 13.

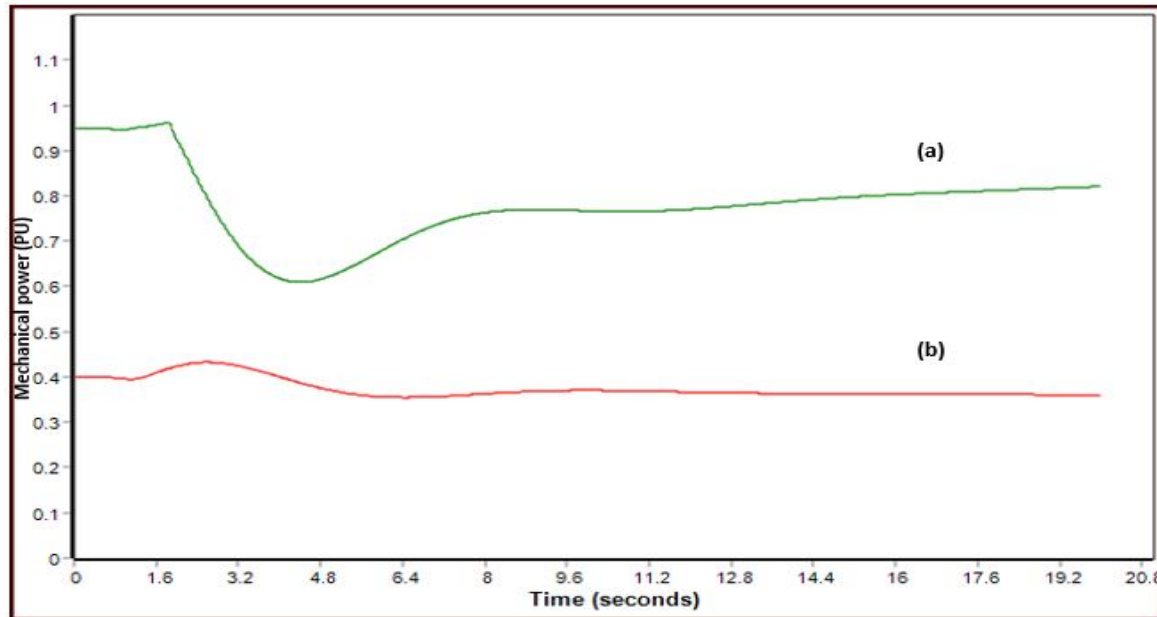

Figure 13: Mechanical power at (a) Kivu watt power (b) Nyabarongo plants after tripping of an 11 MW, 6 MVar load with a shunt reactor of 8 MVar connected to Birembo substation 110 kV busbar.

Figures 12, and 13 show that the swing bus power plant instability arising from power angle variation of 23° (point of power angle stability) can be resolved by adding active devices in the network that gave response to network reactive power variations thereby improving stability of the grid. The active devices in form of shunt reactor prevents the generators' power angle from sudden changing due to reactive power that result into excitation of the machines going out of limits and tripping the units.

5.0 CONCLUSION

In this study, point of stability loss of the grid under study is determined through MATLAB and PSS/E simulation. The critical power angle calculated using both system parameters and corresponding Q and X from MATLAB yielded a value of 23.5° . Simulation in PSS/E by tripping an 11 MW, 6 MVar load while monitoring power angle at the swing bus shows that a subsequent variation of 23° due to this disturbance caused major power plants to trip initiating a long-term instability in the system as is practically observed. The angle variation in the range of 23° to 23.5° can be considered as the power angle point of instability for the system under study since it is in this range that major generators drop to zero or trip. As per simulation results, the introduction of shunt reactors into the system enables grid withstand of a major disturbance in tripping a load consuming more active power than reactive power. This implies that installing of shunt reactors in grids susceptible to loss of stability due to faults is an effective measure to improve system stability during major faults like short-circuits that result in loss of loads and generators.

Acknowledgement

The authors would like to express their gratitude to Rwanda Energy Group for information and grid data support and the Jomo Kenyatta University of Agriculture and Technology for provision of research facilities.

References

- [1] EL-Shimy, M. 2018. Power System Stability. A technical Report. <https://www.researchgate.net>. DOI: 10.13140/RG.2.2.29798.73281.
- [2] Le Roux, P., and Bansal, R. 2018. Transient Stability by means of Generator Tripping, Under Frequency Load Shedding and a Hybrid Control Scheme. *International Journal of Emerging Electric Power Systems*, 19(1): 2017–0228. DOI: 10.1515/ijeeps-2017-0228.
- [3] Michael, P., Masato, T., Tomonobu, S., and Toshihisa, F. 2014. Grid Stabilization with Decentralized Controllable Loads using Fuzzy Control and Droop Characteristics. *International Journal of Emerging Electric Power Systems*. 15(4): 357–365. DOI: 10.1515/ijeeps-2017-0228.
- [4] Mohammad, A., Elsayad, G., Sarhan, M., and Abdin, M. 2017. Power Angle control of virtual synchronous generator. *Journal of Electrical Engineering*. 318140337: 2-3. DOI:10.1515/ijeeps-2014-0022.
- [5] Arcadio, P., José, L., Rueda, T., Stelios, P., Elyas, R., Art, V., and Francisco, G. 2020. Power-Angle modulation controller to support transient stability of power systems dominated by power electronic interfaced wind generation. *Energies* 13(12): 6-12. DOI: 10.3390/en13123178.
- [6] I. K. Okakwu, I., Ogujor, E., and Orukpe, P. 2018. Improving the transient stability of the Nigeria 330kV transmission grid using thyristor controlled series compensator. *Nigerian Journal of Technology*. 37(4): 1092 – 1098. DOI: 10.4314/njt.v37i4.32.
- [7] Surender, S., Reddy, K., and Young H. 2017. Transient Stability Improvement of a System connected with Wind Energy Generators. *International Journal of Emerging Electric Power Systems*, 18(5). DOI: 10.1515/ijeeps-2017-0063.

- [8] Haocheng, Y., Kunkun, N., Dechao, X., and Shuwen, X. 2021. Analysis of power system transient stability characteristics with the application of massive transient stability simulation data. *Journal of Energy*, 7: 111-117. DOI: 10.1016/j.egy.2021.02.015.
- [9] Barsoum, N., Zulkeffley, N., and Songkin, M. 2018. Transient Stability Simulation of 33 kV Power Grid. *Energy and Power Engineering*, 10: 301-318. DOI: 10.4236/epe.2018.106019.
- [10] Changchun, H, Yibo, W., and Wu, S. 2020. Stability analysis of micro-grid frequency control system with two additive time-varying delay. *Journal of the Franklin Institute*, 357: 4949–4963. DOI: 10.1016/j.jfranklin.2019.08.013.
- [11] Himabandu, V., Madhuri, S., and Chandrashekar, D. 2020. The basic electrical engineering course. "Electrical. Available: <https://electrical-engineering-portal.com>. Accessed 13 November 2020.
- [12] Heng, Y. 2016. An Efficient Approach for Fast and Accurate Voltage Stability Margin Computation in Large Power Grids. *MDPI*, 6(335). DOI: 10.3390/app6110335.
- [13] Masahiro, F., Sayed, S., Howlader, M., and Tomonobu, S. 2018. Voltage Stability Improvement of Transmission Systems Using a Novel Shunt Capacitor Control. *International Journal of Emerging Electric Power Systems*. 19(1). DOI: 10.1515/ijeeps-2018-0239.
- [14] Aravinth, A., Vikas, A., Narayanan, K., and Muthukumar, T. 2019. A Multi-Objective Framework to Improve Voltage Stability in A Distribution Network. *International Journal of Emerging Electric Power Systems*. 20(1): 3-4. DOI: 10.1515/ijeeps-2018-0239.
- [15] Kannan, A., Maria, N., Bogdan, D., and Straub, D. 2020. Frequency stability analysis for inverter dominated grids during system split. *Electric Power Systems Research*. 188(06550): 2-5. DOI: 10.1016/j.epr.2020.106550.
- [16] Ellen, W., Robert, S., and Mackay. 2017. A stability analysis of thermostatically controlled loads for power system frequency control. *Hindawi*. 6: 1, 2. DOI: 10.1155/2017/5031505
- [17] Huaichang G., Qinglai, G., Hongbin, S., and Wenlu, Z. 2020. A model and data hybrid-driven shortterm voltage stability realtime monitoring method. *International Journal of Electrical Power and Energy Systems*. 114(105373): 3-4. DOI: 10.1016/j.ijepes.2019.06.031.
- [18] Hong, Y. 2016. Power system reliability and stability. *MDPI*, 9(824): 10-15. DOI: 10.3390/en9100824.
- [19] Gupta, R. 2014. *Power system analysis and design*, 60-65. India: Nirja Publishers & Printers Pte. Ltd, New Delhi, India.
- [20] Shereefdeen, S., Haruna, J., Jimoh, B., and Aliyu, U. 2019. Coherency based Reduction of a Large Power System using PSS/E. *IEEE International Conference on Power, Electrical, and Electronics and Industrial Applications, Kansas, USA* DOI: 10.1109/PeeIACON48840.2019.9071957.
- [21] Chinweika, O., Boniface, A., Chidiogo, N., and Victor, A. 2020. Application of composite method for determining fault location on electrical distribution lines. *Journal of Electrical and Computer Engineering*, 2020: 1-9. DOI: 10.1155/2020/2836940.
- [22] Rwanda Energy Group, 2020. *Transmission and generation Operations data base*, Kigali: Operations department.
- [23] Bashar, S., and Chin, K. 2016. Power System Frequency Stability and Control. *International Journal of Scientific & Engineering Research*, 11(0973-4562): 5688-5695.
- [24] Transmission operations department, 2019. *Grid Control And Monitoring Platform*, Kigali: Electricity Utility Corporation Ltd,
- [25] Power Technology International, 2016. *PSS/E 34.1 Program Operation Manual*. PTI-Siemens Energy,
- [26] Power Technologies International. 2018. *Program Application Guide, Volume II for PSSE Version 34.0*. Siemens Power Technologies International.
- [27] MATLAB, "MathWorks," 1994-2020 The MathWorks, Inc., 2020. [Online]. Available: www.mathworks.com. [Accessed 25 April 2020].
- [28] Arechkik, A., Khalid, L., and Aggour, M. 2017. Steady state and dynamic analysis of renewable energy integration into the grid using PSS/E software," *Energy Procedia*, 141: 119–125. DOI: 10.1016/j.egypro.2017.11.023.
- [29] Csaba F, Andor F. and Tamás D, "Trivent Publishing,"2015. [Online]. Available: <http://trivent-publishing.eu>. [Accessed 10 01 2021].
- [30] Abhyankar, S., and Tushar. 2017. Modeling of transmission line faults for transient stability analysis. *North American Power Symposium, Morgantown, West Virginia*. DOI: 10.1109/NAPS.2017.8107256.
- [31] Sanni, S., Haruna, J., Jimoh, B., and Aliyu, U. 2019. Coherency based Reduction of a Large Power System using PSS/E. *IEEE International Conference on Power, Electrical, and Electronics and Industrial Applications, Kansas, USA*. DOI: 10.1109/PeeIACON48840.2019.9071957.