

## TOMOGRAPHIC IMAGING USING OPTICAL SENSOR ARRAYS

RUZAIRI ABDUL RAHIM<sup>1</sup>, R. G. GREEN<sup>2</sup>

<sup>1</sup> Applied Control Panel, Faculty of Electrical Engineering,  
Universiti Teknologi Malaysia,  
Locked Bag 791, 80990 Johor Bahru, Johor.  
Fax : 075566272 email : Ruzairi@suria.fke.utm.my

<sup>2</sup> School of Engineering, Sheffield Hallam University,  
Pond Street, Sheffield S11WB, England.

**Abstract.** This paper describes an investigation into the use of an optical fibre sensor to measure the flow of pneumatically conveyed solid particles. The diameter of the fibre sensor is 1mm. A tomographic measuring system constructed from arrays of transducer pairs is described, which is capable of capturing sufficient data and reconstruct an image flow. Two arrangement, orthogonal 8 x 8 and 16 x 16 will be discussed later and comparisons of resolution made using phantoms in a pipe of 81mm diameter cross-section with a phantom.

### 1 INTRODUCTION

Process tomography [1] is a measurement technique which uses distributed groups of identical sensors, termed arrays, to investigate the physical properties of the material and its distribution within a container, e.g. a pneumatic conveyor, in real time. For mixtures of transparent fluids and small volume fractions, typically 5%, of opaque solids low-cost optical sensors merit investigation over electrical impedance and X-ray tomography techniques.

To investigate the cross-section of a conveyor with relatively high resolution, 2 mm per cm<sup>2</sup> for example, a large number of peripherally mounted sensors are required. Optical fibres are employed due to their small dimensions (order of 1 mm diameter) which enable them to be spaced at 1.5 to 2.0 mm intervals around the vessel. For process tomography, the sensor must be capable of providing information relating to the concentration of conveyed material within the sensing volume being interrogated.

### 2 OPTICAL FIBRE SENSORS

The sensor system investigated here uses the fibre arrangement shown in figure 1. The transmitter fibre is illuminated with a bright, white light from a halogen bulb excited from a stabilised DC voltage (necessary to prevent fluctuations in supply voltage modulating the light intensity). The light passes through the fibre and then into the volume being interrogated. A receiving fibre detects the transmitted beam and transmits it to a photo-diode and associated electronics, which converts it to an electrical voltage. The fibres have had their ends cut and polished flat to minimise scattering effects. The fibres are mounted into holes machined into the measurement section. The effects of diffraction are ignored.

In the present arrangement sixteen fibres are used for each projection. It is assumed that each fibre produces readings which represent a realistic sample of the solids passing through the space at each side of the fibre. The light source transmits continuously and any particle passing through the volume interrogated by a fibre sensor is detected as a variation in level of illumination by the sensor.

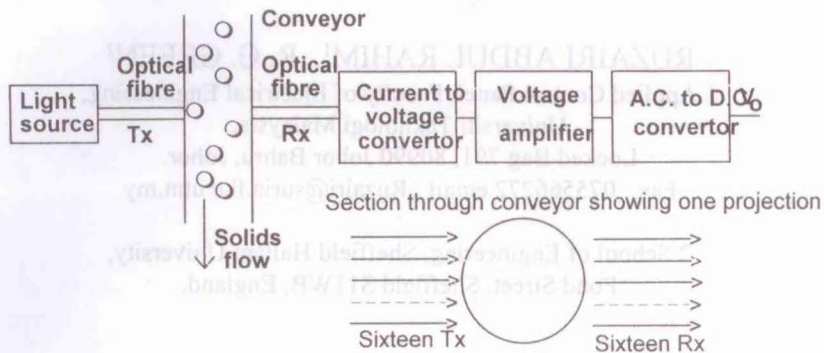

Figure 1 The transducer system.

**2.1 Transducer arrangements**

Initial work was carried out using simplest arrangement possible. This consisted of two arrays of eight transducer each, placed along orthogonal projections to one another. The arrangement was built around a cross-section of the pipe of 81 mm diameter. Figure 2 shows the beam width and spacing inside the pipe for one array. Although the beam diameter is approximately 4mm, the width of detectable beam is only 1mm. This is because the diameter of the receiver fibre is 1mm. The resulting gap between beams is then effectively 9mm. The two distances, beam width and gap between beams are critical factors in the resolution of the system. It cannot be guaranteed that regions of the minor phase with diameter less than 9mm will be detected.

The transducers were connected to data capture system. A simple back-projection algorithm is used to reconstruct an image of the pipe cross-section and output to VDU. Various rods of decreasing diameter were move vertically across the pipe as phantom models. Below a certain diameter the image of the rod intermittently disappeared from the screen as it became lost in the gaps between the beams. The image of the smallest continually displayed rod is shown in figure 3.

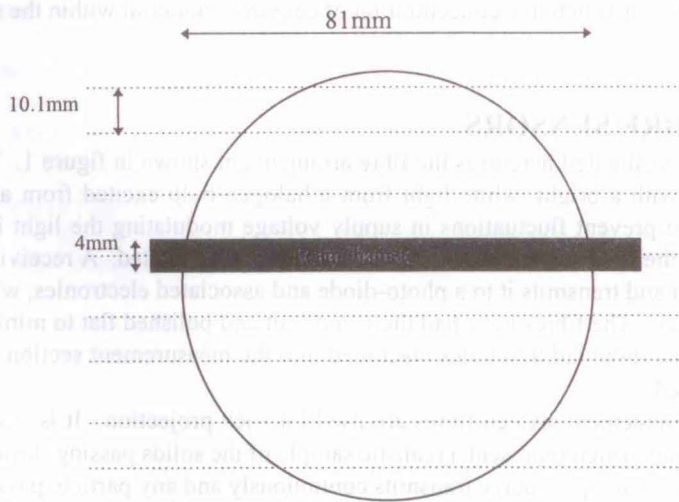

Figure 2 Dimensions of 8 transducer projection

To increase this resolution the sensor arrangement was changed from two arrays of eight to two arrays of sixteen. It was only possible to place the detectors so close, without interference from adjacent beams, due to the optical arrangement. Figure 4 shows the new beam layout for new arrangement. Again various diameter rods were imaged and the resolution improved, as shown in figure 5. Minor phase regions of diameter 5.5 mm and above are guaranteed to be detected.

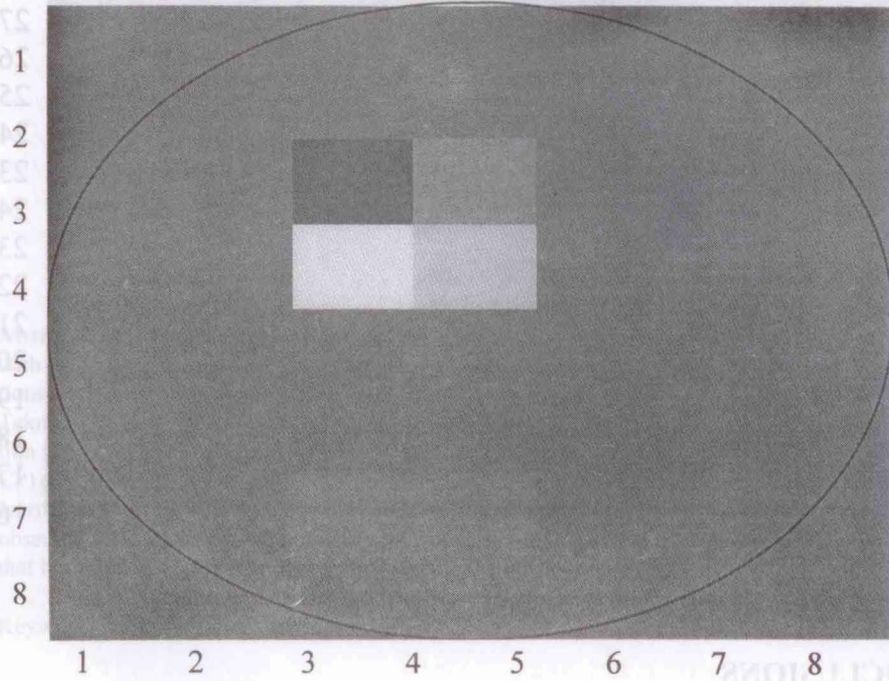

Figure 3 Image from  $8 \times 8$  orthogonal arrangement

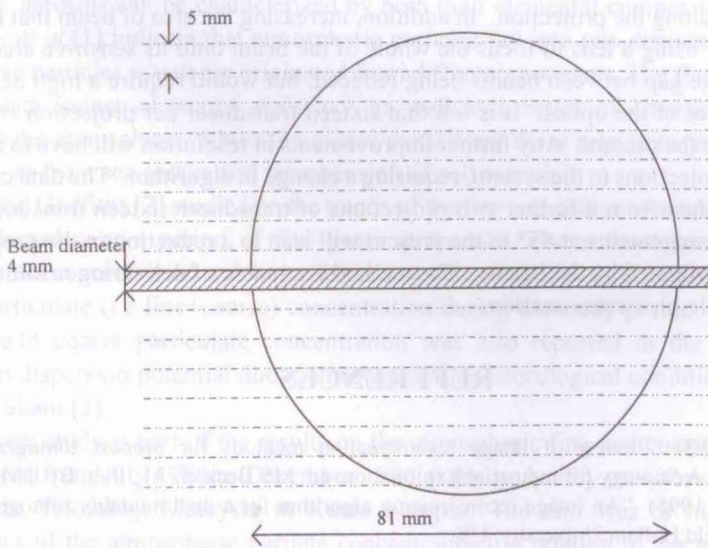

Figure 4 Dimensions of 16 transducer projection

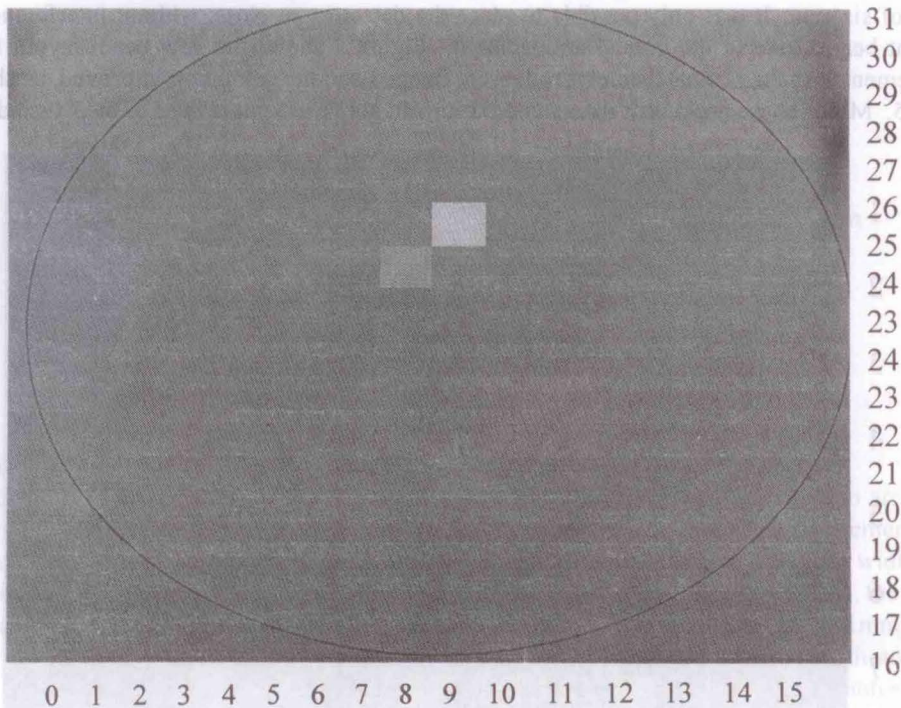

Figure 5 Image from  $16 \times 16$  orthogonal arrangement

### 3 CONCLUSIONS

From the previous section it is possible to see the relative ease with which the resolution of an optical tomography system can be increased. Further improvements can be made by increasing the number of transducer pairs along the projection. In addition, increasing the area of beam that the pin photodiode can detect by using a lens to focus the whole of the beam onto its sensitive area. Both these methods result in the gap between beams being reduced, but would require a high degree of precision in the alignment of the optics. It is felt that sixteen transducer per projection is the optimum hardware design for the present. Any further improvements in resolution will have to come with the addition of more projections to the system, requiring a change in algorithm. The data capture system can accommodate data from a further two projections of transducer sixteen transducer pairs. An extra orthogonal arrangements at  $45^\circ$  to the present will lead to a reduction in the proportion of the pipe that is not interrogated by the beams. The method is capable of delivering resolution of at least 2 mm over the whole pipe cross-section.

### REFERENCES

- [1] C. G. Xie. (1993) "Review of image reconstruction methods for process tomography". Process Tomography - A Strategy for industrial Exploitation, ed. MS Beck et. Al., Pub. By UMIST.
- [2] M. J. Nordin (1995) "An image reconstruction algorithm for a dual modality tomographic system". Thesis, Sheffield Hallam University, UK.