

Modeling of Time-varying Ultra Wideband Multiple-input Multiple-output Channel

Yasser Zahedi^{a*}, Uche A.K. Chude-Onkonkwo^a, Razali Ngah^a, Khalid Zahedi^b, Solomon Nunoo^a

^aWireless Communication Center (WCC), faculty of electrical engineering, Universiti Teknologi Malaysia, 81310 UTM Johor Bahru, Johor, Malaysia

^bFaculty of Computing, Universiti Teknologi Malaysia, 81310 UTM Johor Bahru, Johor, Johor, Malaysia

*Corresponding author: yasserzahedi@gmail.com

Article history

Received :12 July 2012

Received in revised form:

4 April 2013

Accepted :15 April 2013

Graphical abstract

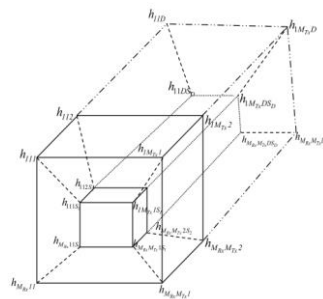

A fourth dimensional tensor (Tesseract) representing the MIMO-UWB time-varying channel. Elements. It can be seen that for each delay tap, there is a fourth dimension related to it. It stands for the scale changes due to the movement.

Abstract

Ultra wideband (UWB) communication is a promising technology for achieving high data rate wireless communications. UWB transmission can be operated in the range of 3.1 to 10.6 GHz with low transmission power to prevent interference with other wireless systems. However, the low transmission power of the UWB signal limits the coverage distance of the UWB system. By using diversity techniques such as the multiple-input multiple-output (MIMO) scheme, enhancement in the communication range can be obtained without compromising data rate. For the purposes of system and network design, it is always important to understand the behavior of the MIMO - UWB channel through modeling. In this paper, we propose a method to derive the synthesis equation for the time-varying MIMO-UWB channel in the time scale-domain. The channel modeling is based on the MIMO correlative modeling approach. The channel operator is represented as a fourth order tensor and the synthesis equation is derived and illustrated. The UWB correlation matrix was plotted for the stationary situation. The results show the importance of the off-diagonal channel correlation elements on the MIMO-UWB channel.

Keywords: MIMO channel; UWB communication; tensor; time-varying

Abstrak

Ultra Wideband komunikasi (UWB) adalah satu teknologi yang menjanjikan untuk mencapai data komunikasi tanpa wayar kadar tinggi. Penghantaran UWB boleh beroperasi dalam julat 3,1-10,6 GHz dengan penghantaran kuasa rendah untuk mengelakkan gangguan dengan sistem tanpa wayar yang lain. Walau bagaimanapun, kuasa penghantaran isyarat UWB yang rendah menghadkan jarak liputan sistem UWB itu. Dengan menggunakan teknik kepelbagaian seperti skim pelbagai masukan-keluaran (MIMO), peningkatan dalam julat komunikasi boleh diperolehi tanpa menjejaskan kadar data. Bagi tujuan rekabentuk sistem dan rangkaian, adalah penting memahami tingkah laku MIMO - saluran UWB melalui model. Dalam penerbitan ini, kami mencadangkan satu kaedah untuk menerbitkan persamaan sintesis untuksaluran MIMO-UWB perubahan masa dalam domain masa. Pemodelan saluran adalah berdasarkan permodelan korelasi MIMO. Pengendali saluran diwakili sebagai tensor peringkat keempat dan persamaan sintesis diterbitkan dan digambarkan. Matriks korelasi UWB diplotkan bagi keadaan pegun. Keputusan menunjukkan kepentingan elemen korelasi saluran luar pepenjuru pada saluran MIMO-UWB.

Kata kunci: Saluran MIMO; komunikasi UWB; tensor, perubahan masa

© 2013 Penerbit UTM Press. All rights reserved.

1.0 INTRODUCTION

Ultra wideband (UWB) communication is a promising wireless technology for achieving high data rate communication systems. UWB signal can be defined as the signal that has a relative bandwidth greater than 20% or an absolute bandwidth of 500 MHz or bigger [1].

Using multiple-input multiple-output (MIMO) scheme along with the UWB communication leads to important achievements. Firstly, it gives the ability to increase the system throughput dramatically [2]. Secondly, MIMO-UWB communication has a longer communication range compare to the single-input single-output (SISO) counterpart [3], and this range increment achievability is vital for a proper and more practical UWB communication distance [4].

Generally, MIMO channel modeling is divided into physical and analytical modeling approaches [5, 6]. Each of these modeling approaches has its own characteristics, merit and demerits usage for the system. A good review about the different types of MIMO channel modeling approaches shall be seen in [5]. A quite number of MIMO narrowband and wideband channel models have been presented in the literature [6-14]. Most of these models were dedicated to the stationary channels [6, 7, 10, 13, 14]. In addition, a small number were focusing on the non-stationary situation [9, 12, 15]. In the case of UWB communication, the mentioned importance of MIMO communication leads to the need of developing channel models. Moreover, the practicality of including mobility has a precious need where some models have been developed for the stationary case [16, 17].

This paper addresses the modeling of time varying MIMO-UWB channel. The channel is represented as a fourth order tensor. The fourth dimension in the tensor stands for the signal scale changes due to the terminal movement. Based on that, the channel elements are represented in a Tesseract (four-dimensional cube). Moreover, the mathematical representation of the synthesis channel is included.

The rest of this paper is organized as follows: Section II gives an insight about the main points of contribution provided through this paper. Section III contains the notations used in this article. The related work is available in section IV. Section V illustrates the time-varying MIMO-UWB channel representation. The proposed model synthesis equation is available in section VI. Results about the UWB correlation matrix are shown in section VII while the paper is concluded in section VIII.

2.0 NOTATION

In this paper, we will use the notation $vec(\bullet)$ to vectorize the matrix or tensor by stacking their column one after the other. $unvec(\bullet)$ to arrange a vector elements into a matrix form. The subscripts \bullet^T , \bullet^H and \bullet^c represent the matrix transpose, the conjugate transpose (Hermitian) of a matrix, and the complex conjugate respectively. Scalars are denoted by small case letters. Vectors by bold upper case letters while matrices are denoted by upper case letters. Bold uppercase letters refer to tensors. \mathcal{H} refers to the four-dimensional channel operator.

3.0 RELATED WORK

In the MIMO system, the correlation between the transmitting and receiving antennas is an important aspect of the MIMO channel modeling [18]. Based on the correlation, the spatial filter characteristics and the mean channel power can be extracted. The simplest analytical MIMO model is the independent and identically distributed (iid) channel model [11]. In this model, it is assumed that all the channel elements in the MIMO channel matrix are uncorrelated [5]. This model assumes the stationarity of the channel. Another model is the Kronecker model [7], which models the MIMO correlation channel matrix as the Kronecker product of the spatial correlation matrices at the transmitter and the receiver and neglecting the joint spatial structure.

$$R_{MIMO} = R_{Rx} \otimes R_{Tx} \quad (1)$$

where R_{MIMO} represents the MIMO narrowband correlation matrix. R_{Tx} and R_{Rx} are the transmitter (base station) correlation matrix, and the receiver correlation matrix, respectively.

The Kronecker model adopts the independence between the scatterers around the transmitter and the ones around the receiver [19]. The model synthesis equation is given by [19]

$$H_{Kron} = R_{Rx}^{1/2} G (R_{Tx}^{1/2})^{1/2} \quad (2)$$

where H is the Kronecker MIMO channel matrix and G is a matrix of complex-Gaussian random elements.

Another narrowband model is the Weichselberger model [6] in which the average coupling between the eigenbases of two link ends is used to model the correlation properties in the MIMO channel. The parameters of this model are the eigenbases of the transmission and reception correlation matrices and the coupling between the direction of arrival (DoA) and the direction of departure (DoD). The synthesis equation for this model is given by

$$H_{Weichselberger} = U_{Rx} (\Omega \odot G) U_{Tx} \quad (3)$$

where U_{Rx} is the receiving side eigenbasis, U_{Tx} is the transmitting side eigenbasis, G is a matrix with iid complex Gaussian entries while Ω represents the coupling matrix.

The Weichselberger model represents an important addition to the MIMO channel modeling through adding the coupling effect on the MIMO channel. This model is also targeted at the stationary channel.

In [14], a worthy wideband MIMO channel model has been introduced. This model is termed the structured model, and is also targeted as stationary channels. The Three dimensional channel tensor was defined to represent the wideband MIMO channel elements. The tensor's third dimension which has been added to the channel matrix represents the delay. In this case, each channel element has different delayed versions. As the bandwidth of the signal increases the number of delay taps increased also. The third order wideband channel tensor is expressed as:

$$H \in \mathbb{C}^{M_{Rx} \times M_{Tx} \times D} \quad (4)$$

where M_{Rx} is the number of receive antennae, M_{Tx} is the number of transmit antennae, and D is the number of delay taps. Higher order singular value decomposition (HoSVD) has been used to obtain the wideband MIMO channel synthesis equation were it is expressed as:

$$H_{struct} = G \times_1 U_{Rx} \times_2 U_{Tx} \times_3 U_{Del} \quad (5)$$

where H_{struct} is the structure model synthetic channel tensor. G represents the core tensor based on the coupling and the complex-Gaussian random variables. U_{Rx} , U_{Tx} and U_{Del} are the one-sided eigenbases of the transmitting, receiving and delay sides.

In [13, 20], The authors developed a hybrid MIMO model that combines the channel characteristics of the wideband structured model [14] and the virtual representation model [8]. The model was expressed in frequency domain instead of the delay domain. Moreover, a transmitter-receiver-frequency tensor was generated to represent channel elements.

The spatial characteristics are described by the eigenbases while the frequency (or delay) domains are described by the steering vectors in order to reduce the complexity in the singular

value decomposition (SVD) operation. However, this decreases from the accuracy compared to the SVD operation as the authors stated. Time-variation in the channel was not addressed in this model.

The virtual channel representation (VCR) models the MIMO channel in the beamspace instead of the eigenspace [21]. Here, steering vectors are used on behalf of the eigenvectors [8]. It is expressed as

$$\mathbf{H}_{virtual} = \mathbf{A}_{R_x}(\tilde{\Omega}_{virtual} \odot \mathbf{G})\mathbf{A}_{T_x}^T \quad (6)$$

\mathbf{A}_{R_x} and \mathbf{A}_{T_x} are steering matrices. $\tilde{\Omega}_{virtual}$ represents the element-wise square root of the coupling matrix $\Omega_{virtual}$.

The accuracy of the VCR model is based on the antenna configuration, and it increases as the number of antennas increase [21]. This model is assume the stationarity of the channel.

A correlation tensor model developed for time-variant frequency selective MIMO channels is proposed in [15]. It focuses on the space and frequency dimensions. Temporal block-wise stationarity has been assumed. In addition, the channel is represented as a fourth order tensor.

$$\mathbf{H} \in M_R \times M_T \times N_f \times N_t \quad (7)$$

Where N_f represents the frequency samples and N_t represents the time samples. The authors assume that for each channel response there are different frequency and time samples. The model is proposed for time-varying frequency selective MIMO channels. Though, it is not designed for the wideband channels where the frequency shifts approximation does not work properly.

4.0 TIME-VARYING MIMO-UWB CHANNEL REPRESENTATION

The linear time varying (LTV) wireless channel is expressed as a linear operator that interacts with the transmitted signal, \mathbf{x} and produces the received signal, \mathbf{y} [22, 23].

$$\mathbf{y} = \mathbf{H}\mathbf{x} \quad (8)$$

In the time-varying situation, the signal is scaled (compressed or dilated) due to the movement of the receiver, transmitter, or a scatterer. In the narrowband channel, the scaling of the signal can be approximated to a Doppler shifts [23]. Therefore, the input-output equation of the system is [24, 25]

$$y(t) = \iint S_H(\tau, \nu) a(t) x(t - \tau) e^{j2\pi\nu t} d\tau d\nu \quad (9)$$

Where $S_H(\tau, \nu)$ represents the delay-Doppler spreading function.

For wideband communication, the approximation of using the Doppler shift instead of the scaling of the signal fails. Even a small scale value can cause a difference in computing the effect of the channel on the transmitted signal. Therefore, time-varying wideband (and of course ultra wideband (UWB) communication channel is better characterized based on the Doppler scale changes and multipath delays. This leads to the usage of time-scale domain instead of the time-frequency or delay-Doppler domain approach.

$$y(t) = \iint W_H(\tau, s) a(t) x((t - \tau) / s) d\tau ds / s^2 \quad (10)$$

where $W_H(\tau, s)$ is the delay-scale spreading function.

In the MIMO communication, the chosen way to exploit spatial diversity, the spatial multiplexing possibility and the beamforming gain feasibility to achieve are all depend on the spatial structure of the MIMO channel (matrix or tensor) elements [6]. Therefore, the statistical description of the MIMO channel should express the spatial structure. Full characterization of the performance of multiple-input multiple-output (MIMO) systems is facilitated by accurate channel models that capture the behavior of true MIMO channels [26].

To model the MIMO channel, analytical channel modeling can be used based on the correlation between the channel elements. The synthesis equation of the channel can be found later, and it should approximate the real channel behavior. In addition, it is important to derive a channel model that puts the time-variation of the channel in consideration. Therefore, in this paper we are proposing a time-varying MIMO-UWB channel model. The time variation is proposed to be based on the scale changes in the multipath signals due to the mobility of the receiver.

In the wideband channel, due to the high bandwidth there will be different ellipses for each group of scatterers that have different path lengths as stated in [27]. This is due to the importance of the delay on the transmitted signal. Therefore, a third dimension has been added to the channel operator matrix leading it to be represented as a third order tensor. In this case for each channel element, there will be different elements based on the delay.

As the receiver moves, the multipath signals will be scaled (compressed or dilated). Therefore, for each delayed channel response (i.e. in one ellipse) the channel element will have many scaled values. In this case the scales elements can be regarded as a dimension inside the delayed channel tensor. The channel operator tensor will be a four dimensions tensor:

$$\mathcal{H} \in \mathbb{C}^{M_{T_x} \times M_{R_x} \times D \times S} \quad (11)$$

S represents the scaling effect due to movement, and it is equal to the number of the delay taps. Each element in the channel tensor has the form as $h_{m,n,d,\varphi}$ where $m \in \{1, \dots, M_{T_x}\}$, $n \in \{1, \dots, M_{R_x}\}$, $d \in \{1, \dots, D\}$, and $\varphi \in \{1, \dots, S\}$. Therefore, each element represent the channel response of the delayed and scaled signal from the transmitter to the receiver. The scenario that representing the time-varying proposed method is shown in Figure. 1

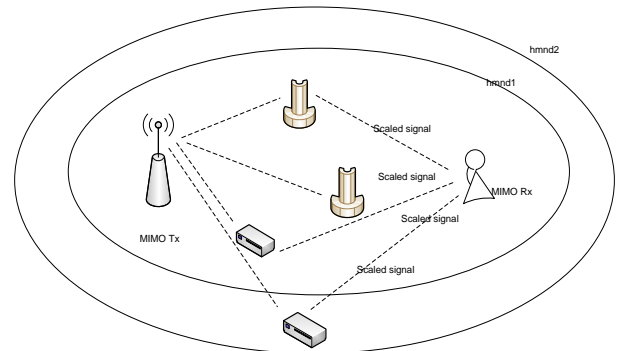

Figure 1 A demonstration of the reception of different scaled signals

As it has been mentioned before, the time-varying MIMO-UWB channel is proposed to be comprised of four dimensions. Here, we proposed the representation of the channel elements as a Tesseract (Four dimensional cube). The Tesseract channel representation illustrates how the channel elements are distributed based on different delay taps (due to the large signal bandwidth) and for different scaling (due to the time variation). Figure 2 exemplifies the channel Tesseract.

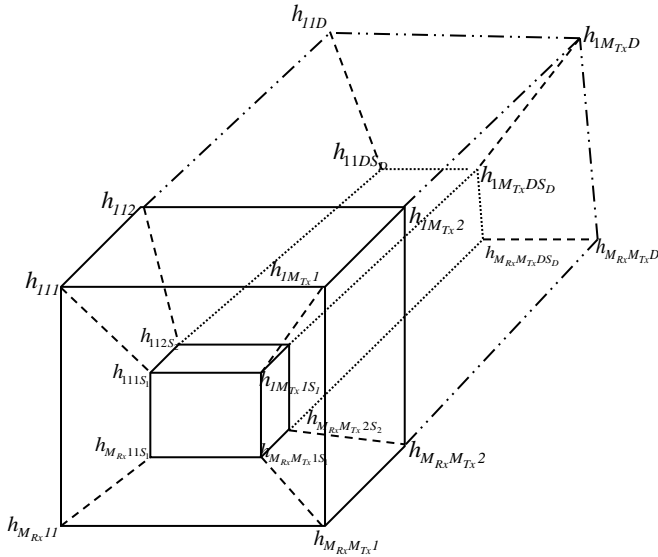

Figure 2 The Tesseract representing the time-varying MIMO-UWB channel elements

It can be seen in figure 2 that the channel element h_{111} represents the channel between one pair of antennas (transmit 1 and receive 1) and for the first delay tap. Caused by mobility, the signal will be changed due to the scaling effect resulting in the changes of the channel value. In this situation, h_{111} is represented as h_{111S} that stands for the time-varying channel element. In the correlative analytical MIMO modeling, the channel synthesis equation is found by [19].

$$\mathbf{h} = \mathbf{R}_H^{1/2} \mathbf{g} \quad (12)$$

where \mathbf{h} is the channel vector, \mathbf{R}_H is the correlation matrix of the MIMO channel elements, and \mathbf{g} is an independent and identically distributed (iid) complex Gaussian vector.

Based on our proposed method, we define the MIMO channel full correlation tensor. The full correlation tensor represents the mutual correlation between all the elements in the channel tensor. The full correlation tensor will be therefore an eighth order tensor.

$$\mathcal{R} = \{ \mathbf{H} \circ \mathbf{H}^* \} \quad (13)$$

Where \circ is the outer product symbol.

For each correlated channel element, the equation will be

$$\mathbf{r}_{m,n,d,\varphi,f,r,l,e} = E\{\mathbf{h}_{m,n,d,\varphi} \mathbf{h}_{f,r,l,e}^*\} \quad (14)$$

where $f \in \{1, \dots, M_n\}$, $r \in \{1, \dots, M_r\}$, $l \in \{1, \dots, D\}$, and $e \in \{1, \dots, S\}$.

The channel correlation tensor can be mapped to a matrix using the symmetric channel-oriented correlation matrix [6]. Therefore, the correlation channel matrix will be composed of the expectation of vectorized elements of the channel tensor.

$$\mathbf{R} = E\{\text{vec}(\mathbf{H})\text{vec}^H(\mathbf{H})\} \quad (15)$$

where (\bullet^H) is the Hermitian transpose.

The channel correlation matrix can be decomposed (due to its Hermitian property) using the eigenvalue decomposition (EVD).

$$\mathbf{R} = \mathbf{U} \mathbf{\Lambda} \mathbf{U}^H \quad (16)$$

where \mathbf{U} is a unitary matrix, and $\mathbf{\Lambda}$ is a diagonal matrix containing the matrix eigenvalues on its diagonal.

Based on the specified eigenvalues and eigenvectors. The correlation matrix can be decomposed using EVD

$$\mathbf{R}_H = \sum_{k=1}^{M_{R_x} \times M_{T_x} \times D \times S} \lambda_k \mathbf{u}_k \mathbf{u}_k^H \quad (17)$$

It is important to find the eigenvectors of the matrix. From the eigenvectors, the eigenbases of the matrix are extracted.

$$\mathbf{U}_k = \text{unvec}(\mathbf{u}_k) \quad (18)$$

In order to reduce the number of parameters that is needed in the full correlation matrix, the one sided correlation matrix concept can be used [6]. In [14], the concept of the one sided correlation matrix proposed in the Kronecker model, and has been extended for wideband MIMO channel. It can be extended too for the time-varying wideband MIMO channel to reveal more about the structure of the channel. From the one-sided correlation matrices, the associated eigenbases and then the eigenvectors can be determined. In this case, the array response of the MIMO system will be extracted.

At this point, a one sided correlation matrix is developed for each dimension in the channel tensor. In this model we consider the correlation in four dimensions, the transmitter, receiver, delay and scale spaces. Therefore, we have four one-sided correlation matrices and they are \mathbf{R}_{R_x} , \mathbf{R}_{T_x} , \mathbf{R}_D and \mathbf{R}_S , and thus it can contain most of the spatial structure of the time varying channel. The receiver one-sided correlation matrix can be represented as

$$\mathbf{R}_{R_x} = E\{\mathbf{H}_{R_x} \mathbf{H}_{R_x}^H\} \quad (19)$$

The transmitter one-sided correlation matrix as:

$$\mathbf{R}_{T_x} = E\{\mathbf{H}_{T_x} \mathbf{H}_{T_x}^H\} \quad (20)$$

Similarly, the delay and the scale correlation matrices are represented as

$$\mathbf{R}_D = E\{\mathbf{H}_D \mathbf{H}_D^H\} \quad (21)$$

$$\mathbf{R}_S = E\{\mathbf{H}_S \mathbf{H}_S^H\} \quad (22)$$

The EVD is applied for each of the one-sided correlation matrices to find the associated eigenbases as it is explained previously.

$$R_{R_x} = \sum_{m=1}^M \lambda_{R_x,m} \mathbf{u}_{R_x,m} \mathbf{u}_{R_x,m}^H = U_{R_x} \Lambda_{R_x} U_{R_x}^H \quad (23)$$

$$R_{T_x} = \sum_{n=1}^N \lambda_{T_x,n} \mathbf{u}_{T_x,n} \mathbf{u}_{T_x,n}^H = U_{T_x} \Lambda_{T_x} U_{T_x}^H \quad (24)$$

$$R_D = \sum_{d=1}^D \lambda_{D,d} \mathbf{u}_{D,d} \mathbf{u}_{D,d}^H = U_D \Lambda_D U_D^H \quad (25)$$

$$R_S = \sum_{s=1}^S \lambda_{S,s} \mathbf{u}_{S,s} \mathbf{u}_{S,s}^H = U_S \Lambda_S U_S^H \quad (26)$$

As in the Weichselberger and the structured model, we assume that there is a coupling between the DoD and DoA spectra, especially for the case of ultra wideband (UWB) communication where there will be a correlation between the scatterers reflection between the transmitter and the receiver [19]. Therefore, a coupling coefficient should be taken in regards.

Wideband coupling variable targeting the time-varying case should be obtained in order to reflect the real spatial structure of the channel. The time-varying wideband MIMO channel synthesis equation can be generalized using the higher order singular value decomposition (HoSVD):

$$\mathcal{H} = \mathfrak{F} \times_1 U_{R_x} \times_2 U_{T_x} \times_3 U_D \times_3 U_D \times_3 U_D \quad (27)$$

where \mathfrak{F} is the core tensor based on the complex Gaussian random variable and the coupling between the eigenbases, $U_{R_x}, U_{T_x}, U_D, U_S$ are the eigenbases for the receiver, transmitter, delay, and scale spaces obtained from the one-sided correlation matrices.

5.0 SIMULATION RESULTS

In this paper, we explain the UWB stationary part of the model. The model based on stationarity case is reduced to be a third dimensions tensor. The coupling matrix representation is used as the one in [14].

The UWB correlation matrix is found based on theoretical channel elements values. It represents the correlation values between the MIMO channel elements. Large number of delay taps has been used to convey the UWB signal behavior.

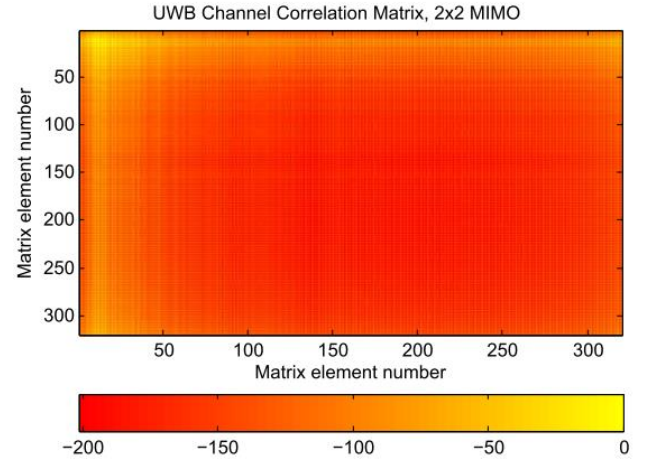

Figure 3 UWB channel correlation matrix for simulation of 2x2 MIMO

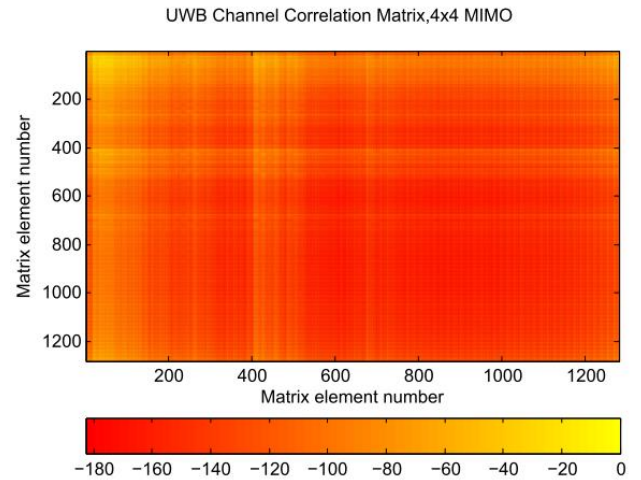

Figure 4 UWB channel correlation matrix for simulation of 4x4 MIMO

As it is shown in Figure 3 and 4, the importance of the off-diagonal blocks is high for the UWB communication. This indicates that there are high correlation values between different channel elements instead of the same channel elements. This is due to the high bandwidth in the UWB signal. In this case the effect of the off-diagonal blocks should be taken in regards for the channel model.

It can be seen also that the importance of the on-diagonal blocks (that represents the values of same elements correlation values) increase as the number of antennas increase in the MIMO system. Therefore, MIMO spatial structure accuracy increases proportionally with the number of antennas.

6.0 CONCLUSION

In this paper we presented the synthesis channel equation for a time-varying correlative model for UWB-MIMO communication. The model addressed the time variation via the scale changes for the time scale domain which is preferred for the wideband and ultra wideband signals. The scale changes are proposed to be added as a fourth dimension in the linear channel operator. The justification of adding the fourth dimension has been elaborated. In this part, the MIMO-UWB channel correlation matrix was simulated for the stationary case.

References

- [1] A. F. Molisch. 2005. Ultrawideband Propagation Channels-theory, Measurement, and Modeling. *Vehicular Technology, IEEE Transactions*. 54: 1528–1545.
- [2] T. Kaiser, F. Zheng, and E. Dimitrov. 2009. An Overview of Ultra-wideband Systems with MIMO. *Proceedings of the IEEE*. 97: 285–312.
- [3] Z. Qiyue, A. Tarighat, and A. H. Sayed. 2007. Performance Analysis of Multiband OFDM UWB Communications with Application to Range Improvement. *Vehicular Technology, IEEE Transactions*. 56: 3864–3878.
- [4] A. F. Molisch. 2010. MIMO-UWB Propagation Channels. 1–6.
- [5] P. Almers, E. Bonek, A. Burr, N. Czink, M. Debbah, V. Degli-Esposti, et al. 2007. Survey of Channel and Radio Propagation Models for Wireless MIMO Systems. *EURASIP Journal on Wireless Communications and Networking*. 56–56.
- [6] W. Weichselberger. 2003. Spatial Structure of Multiple Antenna Radio Channels. *Institut für Nachrichtentechnik und Hochfrequenztechnik*.
- [7] J. P. Kermoal, L. Schumacher, K. I. Pedersen, P. E. Mogensen, and F. Frederiksen. 2002. A Stochastic MIMO Radio Channel Model with Experimental Validation. *Selected Areas in Communications, IEEE Journal*. 20: 1211–1226.
- [8] A. M. Sayeed. 2002. Deconstructing Multiantenna Fading Channels. *Signal Processing, IEEE Transactions*. 50: 2563–2579.
- [9] M. P. Ali Chelli. 2011. A Non-Stationary MIMO Vehicle-to-Vehicle Channel Model Derived from the Geometrical T-Junction Model. In *Vehicular Technologies: Increasing Connectivity*. M. Almeida, Ed.
- [10] K. I. Pedersen, J. B. Andersen, J. P. Kermoal, and P. Mogensen. 2000. A Stochastic Multiple-Input-Multiple-Output Radio Channel Model for Evaluation of Space-Time Coding Algorithms. In *Vehicular Technology Conference, 2000. IEEE VTS-Fall VTC 2000*. 52nd. 893–897.
- [11] E. Telatar. 1999. Capacity of Multi-antenna Gaussian Channels. *European Transactions on Telecommunications*. Wiley Online Library.
- [12] M. Pätzold and B. O. Hogstad. 2008. A Wideband MIMO Channel Model Derived from the Geometric Elliptical Scattering Model. *Wireless Communications and Mobile Computing*. 8: 597–605.
- [13] O. E. e. a. Yan Zhang. 2012. A General Coupling-based Model Framework for Wideband MIMO Channels. *IEEE Transactions on Antennas and Propagation*. 60: 2.
- [14] N. Costa, S. Member, S. Haykin, and L. Fellow. 2008. A Novel Wideband MIMO Channel Model and Experimental Validation. *IEEE Transactions on Antennas and Propagation*. 56: 550–562.
- [15] M. Weis, G. Del Galdo, and M. Haardt. 2007. A Correlation Tensor-based Model for Time Variant Frequency Selective MIMO Channels. *Proceedings of International ITG/IEEE Workshop on Smart Antennas (WSA'07)*.
- [16] X. Hong, C. X. Wang, B. Allen, and W. Q. Malik. 2007. Correlation-based Double-directional Stochastic Channel Model for Multiple-antenna Ultra-wideband Systems. *Microwaves, Antennas & Propagation, IET*. 1: 1182–1191.
- [17] J. Adeane, W. Malik, I. Wassell, and D. Edwards. 2007. Simple Correlated Channel Model for Ultrawideband Multiple-input Multiple-output Systems. *Microwaves, Antennas & Propagation, IET*. 1: 1177–1181.
- [18] Y. S. Cho, J. Kim, W. Y. Yang, and C. G. Kang. 2010. *MIMO-OFDM Wireless Communications with MATLAB*: Wiley.
- [19] N. Costa and S. Haykin. 2010. *Multiple-input, Multiple-output Channel Models: Theory and Practice*. 65: Wiley-Interscience.
- [20] Y. Zhang, X. Hu, Y. Jia, S. Zhou, X. Chen, and J. Wang. 2009. A Novel Coupling-based Model for Wideband MIMO Channel. 1–6.
- [21] M. Ozcelik, N. Czink, and E. Bonek. 2005. What Makes a Good MIMO Channel Model? 1: 156–160.
- [22] P. Bello. 1963. Characterization of Randomly Time-variant Linear Channels. *Communications Systems, IEEE Transactions*. 11: 360–393.
- [23] F. Hlawatsch and G. Matz. 2011. *Wireless Communications Over Rapidly Time-Varying Channels*. Academic Press.
- [24] G. Matz and F. Hlawatsch. 2006. Time-varying Communication Channels: Fundamentals, Recent Developments, and Open Problems.
- [25] U. A. K. Chude-Onkonkwo, R. Ngah, and T. Abd Rahman. 2011. Time-scale Domain Characterization of non-WSSUS Wideband Channels. *EURASIP Journal on Advances in Signal Processing*. 1–20.
- [26] J. Wallace and B. Maharaj. 2007. Accurate MIMO Channel Modeling: Correlation Tensor vs. Directional Approaches. 3750–3754.
- [27] J. Parsons and A. Bajwa. 1982. Wideband Characterisation of Fading Mobile Radio Channels. *Communications, Radar and Signal Processing, IEE Proceedings F*. 129: 95.