

Investigation of Ferroresonance Mitigation Techniques in Voltage Transformer Using ATP-EMTP Simulation

Zulkurnain Abdul-Malek^{a*}, Kamyar Mehranzamir^a, Behnam Salimi^a, Hadi Nabipour Afrouzi^a, Saeed Vahabi Mashak^a

^aInstitute of High Voltage and High Current (IVAT), Faculty of Electrical Engineering, Universiti Teknologi Malaysia, 81310 UTMJohor Bahru, Johor, Malaysia

*Corresponding author: zulkurnain@utm.my

Article history

Received :15 February 2013

Received in revised form :
10 June 2013

Accepted :16 July 2013

Graphical abstract

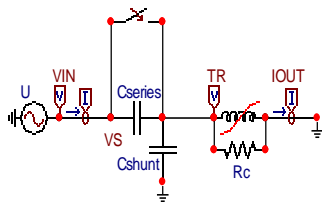

Abstract

Ferroresonance is a complex nonlinear electrical phenomenon that can cause dielectric and thermal problems for electrical equipment. Electrical systems with ferroresonant behavior are nonlinear dynamical systems. The ferroresonance phenomenon may take place when the core of an inductive device becomes saturated, and its current flux characteristic becomes nonlinear. While in the case of a linear resonant circuit the resonance frequency is well defined, in the case of a nonlinear circuit, the oscillations may exist at various frequencies, depending on many factors of the particular case. In this paper, ferroresonance phenomenon and its mitigation techniques in 33 kV/110 V voltage transformers (VT) were studied using ATP-EMTP simulation. Initial investigations were carried out for the VT failures occurred at one substation in Malaysia. Physical and burn characteristics of the failed VTs were studied. Simulation results show that ferroresonance cannot be proven to have occurred at the VT due to switching operations since one precondition, namely the critical capacitance, could not have been satisfied. However, in the event of a ferroresonance occurring, several mitigation techniques such as using load resistors, proper grounding sequence, reconfiguration of VT connection, and overcurrent and overvoltage protection can be implemented.

Keywords: Ferroresonance; ATP/EMTP; voltage transformers; over-voltages; over-currents; mitigation techniques

Abstrak

Ferroresonance adalah satu fenomena elektrik linear yang kompleks yang boleh menyebabkan masalah dielektrik dan terma untuk peralatan elektrik. Sistem elektrik dengan tingkah laku ferroresonant adalah sistem dinamik tak linear. Fenomena ferroresonance boleh berlaku apabila teras peranti induktif menjadi tepu, dan ciri-ciri fluks semasa menjadi linear. Walaupun dalam kes litar salunan linear frekuensi resonans yang ditakrifkan dengan baik, dalam kes litar linear, ayunan mungkin wujud pada pelbagai kekerapan, bergantung kepada banyak faktor kes yang tertentu. Dalam kertas kerja ini, fenomena ferroresonance dan teknik pengurangan di 33 kV/110 V voltan transformer (VT) telah dikaji menggunakan simulasi ATP-EMTP. Siasatan awal telah dijalankan bagi kegagalan VT berlaku pada satu pencawang di Malaysia. Ciri-ciri fizikal kebakaran dan kegagalan VTS dikaji. Keputusan simulasi menunjukkan ferroresonance yang tidak dapat dibuktikan telah berlaku pada VT kerana operasi beralih kerana satu pra-syarat, iaitu kemuatan yang kritikal, tidak dapat diselesaikan. Walau bagaimanapun, sekiranya ferroresonance berlaku, beberapa teknik pengurangan seperti menggunakan beban perintang, rangkaian asas yang betul, konfigurasi sambungan VT, dan perlindungan pada lebihan arus dan lebihan voltan boleh dilaksanakan.

Kata kunci: Ferroresonance; ATP/EMTP; voltan transformers; lebihan voltan; lebihan arus; teknik pengurangan

© 2013 Penerbit UTM Press. All rights reserved.

1.0 INTRODUCTION

Ferroresonance is a complex nonlinear electrical phenomenon that can cause dielectric and thermal problems for electric power equipment. The term 'ferroresonance' has appeared in publications dating as far back as the 1920s, and it refers to all oscillating phenomena occurring in an electrical circuit which contains a nonlinear inductor, a capacitor, and a voltage source [1–3].

Ferroresonance does not occur customarily or predictably in response to a precise stimulus, hence it is troublesome to analyse it. The stable steady state responses are not unique in these systems, which means more than one response can come from the same initial circuit parameters.

The system can jump to an unexpected nonlinear state from normal steady state conditions in reaction to a transient voltage, phase to ground fault, energization or deenergization of the

equipment, induced overvoltages of lightning, or any other rapid changes. This circumstance can impose severe harmonic distortion and high (several per unit) overvoltages on the system, which can seriously damage power system equipment [3, 4].

The ferroresonance phenomenon may take place when the core of an inductive device becomes saturated, and its current flux characteristic becomes nonlinear. While in the case of a linear resonant circuit the resonance frequency is well defined, in the case of a nonlinear circuit, the oscillations may exist at various frequencies, depending on many factors of the particular case. Customary linear mathematics has problems construing ferroresonance phenomena, so it is not fully appropriate for the study of ferroresonance [1, 5-7].

The largest electricity utility company in Malaysia, TNB (Tenaga Nasional Berhad), has had several failures of 33 kV voltage transformers (VT) in its distribution system. This paper aims to determine whether the cause of the failures is due to a ferroresonance effect. The simulation work also proposes several mitigation techniques that can be applied to reduce or eliminate the ferroresonance effect.

2.0 TECHNICAL BACKGROUND OF FERRORESONANCE

In power system applications, ferroresonance is commonly linked to an oscillating phenomenon having a nonlinear inductor, a capacitor, and a voltage source, and resulting in highly distorted overvoltages and overcurrents. The first step in understanding the ferroresonance phenomenon is to grasp the concept of resonance, which can be explained by using a simple RLC circuit as shown in Figure 1.

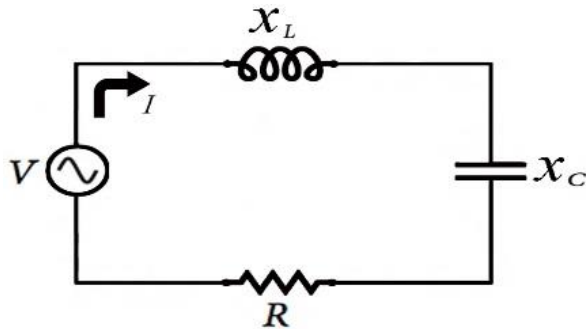

Figure 1 RLC circuit for defining ferroresonance phenomena

This linear circuit resonates at some given frequencies when the inductive (X_L) and capacitive (X_C) reactance cancel each other out. These impedance values are predictable and change with frequency variations. The capacitance C will always have a capacitive reactance as in Equation 1, and the inductance L will always have an inductive reactance as in Equation 2, where ω is the frequency of the source.

$$X_C = 1 / j \omega C \tag{1}$$

$$X_L = j \omega L \tag{2}$$

$$I = V / (R + X_L - X_C) = V / R \tag{3}$$

The current, as seen in Equation 3, depends on the resistance R. The condition in Equation 3 happens only when ferroresonance occurs. If this resistance is small, then the current can become very large in the RLC circuit. The size of this current during resonance can be predicted by Equation 3. If the inductor in Figure 1 is replaced by an iron core nonlinear inductor, the exact values of the voltage and current cannot be predicted as they could be in a linear model. Equation 3 will not indicate the size of the current produced [4–6].

As the current is increased, so does the magnetic flux density until a certain point where the slope is no longer linear, and an increase in current leads to modest increases in magnetic flux density. This point is called the saturation point. Figure 2 shows the relationship between the magnetic flux density and the current.

As the current increases in a ferromagnetic coil past the saturation point, the inductance of the coil changes very quickly. This allows the current to take on dangerously high values. It is these high currents which make ferroresonance cause damage to the equipment. Most transformers have cores made of ferromagnetic material. This is why ferroresonance is a concern for transformer operation [3–6].

When ferroresonance occurs it can be identified by certain distinct characteristics. In ferroresonance phenomena, the steel core is driven into the saturation point, leading to an audible noise. As the core goes into a high flux density, magnetostriction forces cause a movement in the core laminations. This sound is different than the normal hum murmuring sound, a constant droning sound, of a transformer in normal operation. Ferroresonance can cause high over-voltages and currents. It can cause irreparable damage to both the primary and secondary circuits of a transformer. The heating caused by the over-currents may cause permanent damage to the transformer insulation. Even worse, the transformer could fail completely.

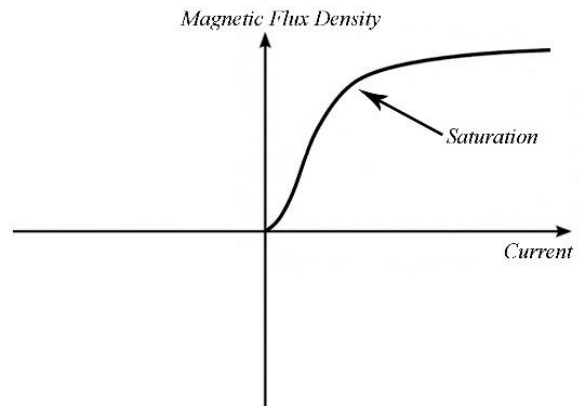

Figure 2 Magnetization curve

As is obvious from Figure 3, the junction between the inductive reactance (X_L) line and the capacitive reactance (X_C) line produces the current in the circuit and the voltage across the inductor, V_L . At resonance, these two lines become parallel, yielding solutions of infinite voltage and current (assuming a lossless element). When X_L is no longer linear, such as with a saturable inductor, the X_L reactance can no longer be represented by a straight line. The graphical solution is now as shown in Figure 4. Ferroresonance occurs because the inductance in the circuit is ferromagnetic; meaning that it has a core made of a ferromagnetic material, usually iron. A transformer is an excellent example of a ferromagnetic inductance [4-9].

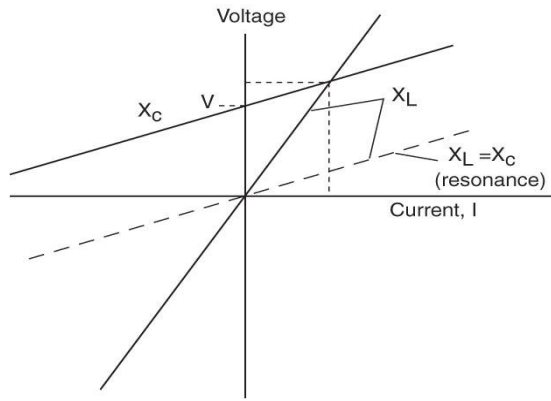

Figure 3 Graphical solution of linear LC circuit

In the ordinary power system situation, the ferroresonance phenomena take place when a transformer becomes isolated on a cable part in such a manner that the cable capacitance appears to be in series with the magnetizing characteristic of the transformer. For short lengths of cable, the capacitance is very small and there is one solution in the third quadrant at relatively low voltage levels.

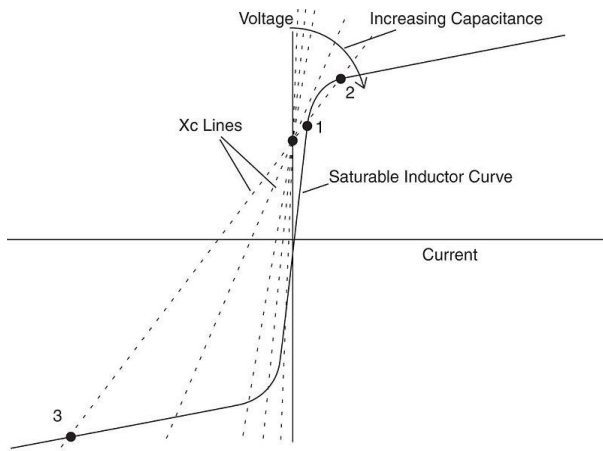

Figure 4 Graphical solution of nonlinear LC circuit

As the capacitance increases, the solution point creeps up the saturation curve in the third quadrant until the voltage across the capacitor is well above normal. These operating points may be relatively stable, depending on the nature of the transient events that precipitated the ferroresonance.

2.1 Power System Ferroresonance

The following four things are necessary for ferroresonance to occur. First, a sinusoidal voltage source is needed, for which a power system generator will do quite nicely. Secondly, ferromagnetic inductances, these can be power transformers or voltage transformers. The third one is capacitance: this can come from installed power system capacitors, the capacitance to ground of transmission lines, the large capacitance of an underground cable, or the capacitance to ground of an ungrounded system. Finally low resistance: this can be a lightly loaded power system, (an unloaded transformer for example), a low short circuit power source, or low circuit losses [7-10].

3.0 FERRORESONANCE MODELING

The investigation was specifically carried out for the VT failure at PMU Kota Kemuning in Malaysia. The Electromagnetic Transients Program (EMTP) was used to simulate this real system. Figure 5 shows the simplified single line diagram for the 132/33 kV PMU Kota Kemuning (substation in Selangor, Malaysia). At 00:45 hour, PMU Kota Kemuning 3T0 reported a trip resulting from the explosion of a 33 kV, VT red phase. The equipment details are shown in Table 1. The fault had also caused the tripping of another 33 kV 2000A D/B VCB 3T0 [3–5].

The sequence of events during the time of the VT failure was also recorded by a TNB event recorder and the substation alarm monitoring system (SAMS). The 132 KV incoming circuit-breaker (310) is seen to have opened at 00:49:35 due to the faulty VT. It was also reported that there were cracks on the VT, and that parts of it had chipped off. All three VT fuses had open-circuited and the screw cap contact surface with the termination bars was badly pitted. The rear covers and support channels were damaged from the buildup of pressure caused within the panel.

3.1 Modelling of Magnetic Core Characteristics

EMTP is a computer simulation program specially designed to study transient phenomena in a power system. It contains a large variety of detailed power equipment models or builds in setups that simplify the tedious work of creating a system representation. Generally, this simulation software can be used in the design of an electrical system or in detecting or predicting an operating problem of a power system. ATP-EMTP is used in this simulation process to observe the electrical response of the transmission system.

ATP-EMTP software includes two kinds of nonlinear components: type 93 is a true nonlinear model, and the other type includes two pseudo-nonlinear models called type 96 and type 98.

The nonlinearity of the element is clearly delineated as a nonlinear function in the true nonlinear model, such as the flux as a function of the current. The software, using the Newton–Raphson method, solves a combination of nonlinear equations and an appropriate system equivalent at each time step. In the pseudo-nonlinear models, the nonlinearity is modeled as a number of piecewise linear segments. This method converts the segment slopes into a Norton equivalent with a resistor in parallel with an appropriate current source [6–11]. In this paper, the true nonlinear model type 93 was used to represent the magnetic core characteristics of the voltage transformer. The magnetization curve data is given in Table 2.

The value of current versus voltage was obtained at the secondary side of the voltage transformer. The current versus voltage values for the primary side were calculated by applying the turn ratio factor. Table 3 shows the calculated rms and p.u (per unit) values for the primary side of the voltage transformer.

3.2 Reduced Equivalent Ferroresonant Circuit

The ferroresonance condition can be simulated provided all three preconditions discussed earlier are satisfied. The system arrangement for 3T0 VT shown in Figure 5 can be effectively reduced to an equivalent ferroresonant circuit as shown in Figure 6. The sinusoidal supply voltage (e) is coupled to the VT through a series capacitor C_{SERIES} . The VT’s high voltage winding shunt capacitance to ground can greatly contribute to the value of C_{SHUNT} .

The resistor R is basically made up of the VT’s equivalent magnetizing branch resistance (coreless resistance). The nonlinear inductor is represented by a nonlinear flux linkage versus current curve in Figure 6.

Figure 7 shows the simulated circuit in ATP. The switch can represent the circuit breaker or the ‘disconnection’ of the fuse due to its operation. After the circuit breaker or the fuse opens, it is proposed that the supply voltage can still be coupled to the VT through equivalent series capacitance, C_{SERIES} .

The voltage transformer was modeled as a nonlinear inductor type 93 in parallel with a resistance in the magnetizing branch (R_c). The circuit opening is represented by a time controlled switch.

The values of all the circuit components in Figure 7 were determined based on the actual parameters, as far as possible. The following values in Table 4 were obtained from measurements made on the VT.

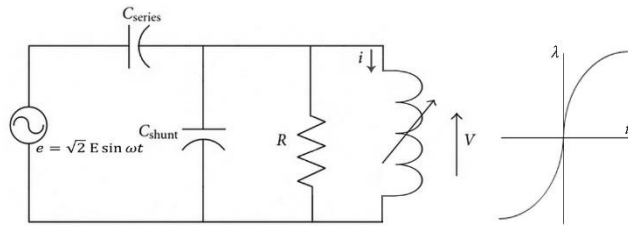

Figure 6 Reduced equivalent ferroresonant circuit

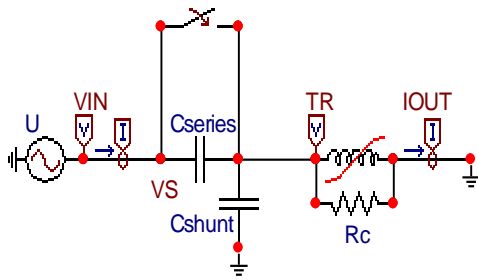

Figure 7 The transformer ATP simulated reduced equivalent ferroresonant circuit

Table 1 VT detailed specifications

VT Type	UP 3311
Form	V50
Accuracy Class	0.5
Primary Voltage	33/3 kV
Secondary Voltage	110/3 kV
Rated Output	100 VA
Standard	BS 3941
Insulation Level	36/70/170 kV
Number of phase	1
Frequency	50 Hz
V.F	1.2 Cont 1.9 30 SEC

Table 2 The RMS value of current and voltage at secondary side

Current (A)	Voltage (V)
0.147	9.51
0.257	19.88
0.352	30.16
0.466	40.61
0.567	49.83
0.731	60.79
0.869	69.88
0.929	72.59
1.082	81.81
1.266	90.78
1.444	97.74
1.846	111.51
4.000	125.00

Table 3 The rms and p.u (per unit) current and voltage value of primary side

Irms(mA)	Ipu	Vrms(kV)	Vpu
0.490	0.283	2.853	0.150
0.857	0.495	5.962	0.313
1.173	0.677	9.050	0.475
1.533	0.897	12.186	0.640
1.890	1.091	14.949	0.785
2.440	1.409	18.235	0.957
2.897	1.673	20.960	1.100
3.097	1.788	21.775	1.143
3.607	2.083	24.541	1.288
4.220	2.436	27.234	1.430
4.813	2.779	29.324	1.539
6.153	3.553	33.455	1.756
13.330	7.696	37.509	1.969

Table 4 Measurements on the VT

Parameter	Measured value
CHV-gnd	97.4 pF
DF of CHV-gnd	51.88 %
CHV-LV	640.7 pF
DF of CHV-LV	0.938 %
CLV-gnd	328.7 pF
DF of CLV-gnd	7.462 %
Rc	16.9 MΩ
	(calculated from open circuit test data)

4.0 SIMULATION RESULTS

4.1 Simulation of Capacitance Precondition (Effect of Changing C_{SERIES})

In this section, the effect of changing the values of the series capacitors is considered. The purpose of this series of simulations is to determine the range of series capacitance values within which the ferroresonance is likely to occur. If the range of values required for the ferroresonance’s occurring are within a realistic range, for example, the series capacitance represented by the open circuited fuse can be tested from the physical dimensions, and then ferroresonance may occur under such a configuration.

The simulation was carried out with a fixed value of the shunt capacitor (C_{SHUNT}) at 97.4 pF and the value of the resistance in the magnetizing branch (R_c) at 16.9 MΩ. The circuit was supplied by an AC source, peak voltage 26.94 kV, with 50 Hz frequency. The time controlled switch was closed at 0 sec and disconnected after 0.25 sec.

Table 5 shows the effect of varying the series capacitor values. The peak voltage and the peak current at the VT were recorded

before and after the switch were operated. The time from 0 sec until 0.25 sec was considered as the before switch opening, and the remaining time was considered to be after the switch opening. Figure 8 shows the output waveforms for a 50 pF series capacitor

where ferroresonance has not occurred. Figure 9 displays the output waveforms for a 1500 pF series capacitor value where ferroresonance has occurred.

Table 5 The effect of changing the value of series capacitor

C_{SERIES} (pF)	Peak Voltage at Transformer (kV)		Peak Current at Transformer (mA)		Frequency of System (Hz)		Ferroresonance Occur
	Before	After	Before	After	Before	After	
8000	26.944	27.941	4.136	3.947	50	50	No
4000	26.943	28.895	4.137	4.483	50	50	No
2000	26.943	32.844	4.137	5.612	50	50	No
1500	26.943	35.297	4.135	5.951	50	50	Yes
1000	26.943	52.429	4.136	47.166	50	50	Yes
500	26.944	44.228	4.136	20.813	50	50	Yes
350	26.943	41.609	4.137	9.143	50	50	Yes
200	26.943	24.275	4.137	3.548	50	50	No
100	26.943	8.846	4.134	1.245	50	50	No
50	26.943	3.035	4.135	5.561	50	50	No

4.2 Simulation of Capacitance Precondition (Effect of Changing C_{SHUNT})

This simulation was carried out with a fixed series capacitor (C_{SERIES}) at 50 pF and the value of the resistance in the magnetizing branch (RC) at 16.9 M Ω . The circuit was supplied by an AC source, peak voltage 26.94 kV, with 50 Hz frequency. The time controlled switch was closed at 0 sec and disconnected after 0.25 sec.

Table 6 shows the effect of changing the shunt capacitor. The output waveform for a 40 pF shunt capacitor where ferroresonance has occurred is illustrated in Figure 10. Figure 11 shows the output waveforms for a 400 pF shunt capacitor value where ferroresonance has not occurred. It is clear from Table 6 that the shunt capacitor must be over 320 pF to prevent the occurrence of ferroresonance.

When ferroresonance happens, the peak voltage and the peak current increase too much compared with before ferroresonance. There is sufficient energy dissipation through power system loads and losses to dampen ferroresonance. However, in lightly loaded systems (e.g., rural distribution feeders), the possibility of ferroresonance is greater.

The occurrence of ferroresonance is usually marked by large overvoltages and overcurrents with highly distorted waveforms which can pose significant safety hazards and cause irreparable damage to equipment. Therefore, mitigation techniques were used here to neutralize the ferroresonance [10, 11].

5.0 MITIGATION TECHNIQUES

Much research has been done to find ferroresonance mitigation methods. In this section, a number of ferroresonance mitigation techniques have been analyzed. Simulations have been carried out to observe the effects of the suggested techniques on the occurrence of ferroresonance.

5.1 Application of Load Resistance

Resistors can be connected at the secondary side of the voltage transformer to prevent or interrupt ferroresonance.

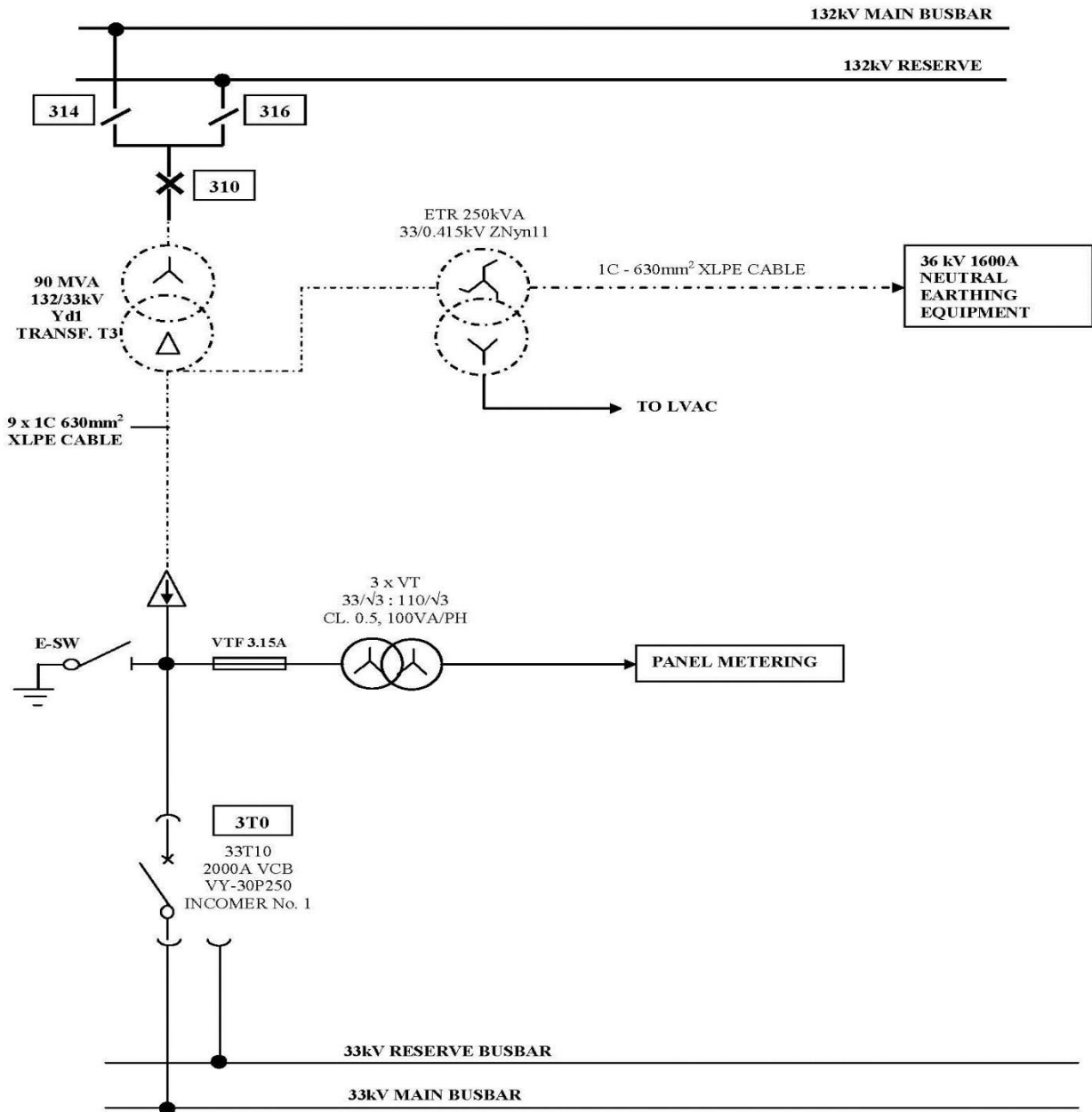

Figure 5 Single line diagram of the substation

Table 6 The effect of changing the value of shunt capacitor

C_{SHUNT} (pF)	Peak Voltage at Transformer (kV)		Peak Current at Transformer (mA)		Frequency of System (Hz)		Ferro-resonance
	Before	After	Before	After	Before	After	
0.312	26.943	43.431	4.132	17.161	50	50	Yes
0.625	26.943	43.433	4.136	17.173	50	50	Yes
1.25	26.943	43.435	4.137	17.151	50	50	Yes
2.5	26.943	43.446	4.132	17.241	50	50	Yes
5	26.943	43.463	4.137	17.334	50	50	Yes
10	26.943	43.495	4.135	17.535	50	50	Yes
20	26.943	43.563	4.136	17.914	50	50	Yes
40	26.943	43.720	4.132	18.668	50	50	Yes
80	26.943	44.052	4.134	20.09	50	50	Yes
160	26.943	44.793	4.135	22.86	50	50	Yes
320	26.943	33.558	4.135	5.712	50	50	No

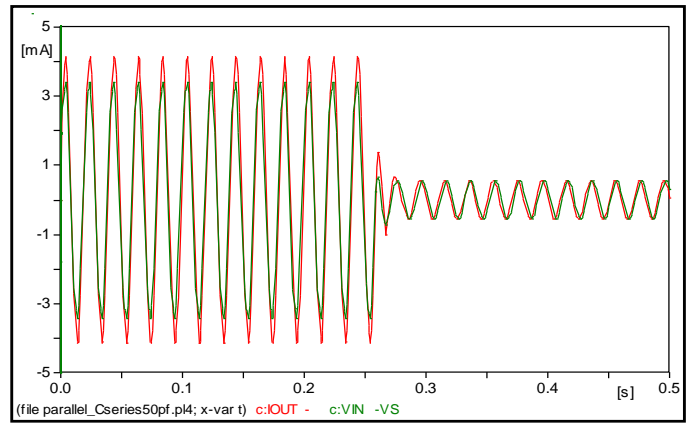
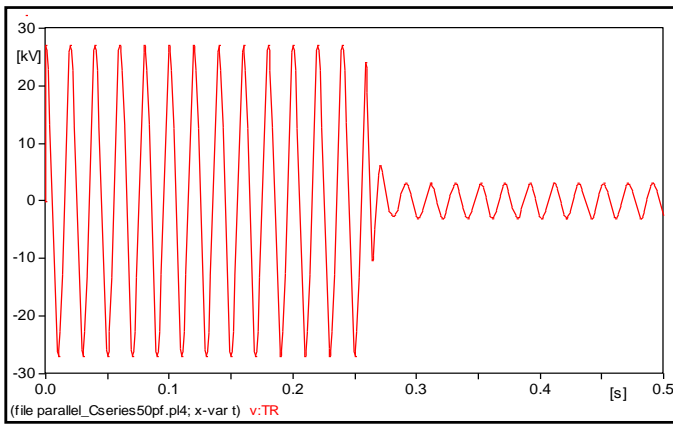

Figure 8 The output waveform for 50 pF series capacitor

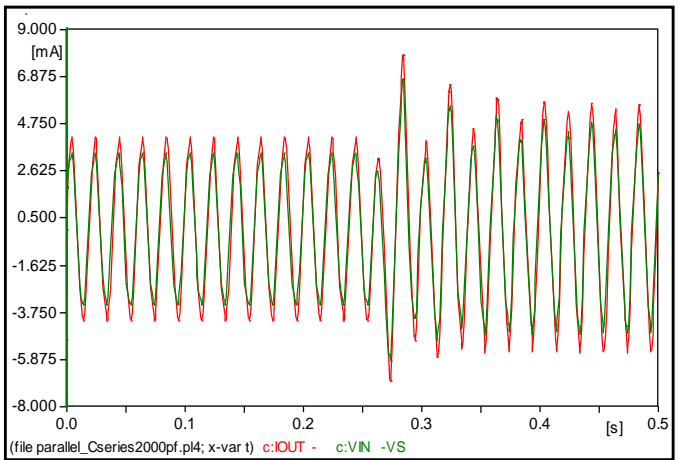
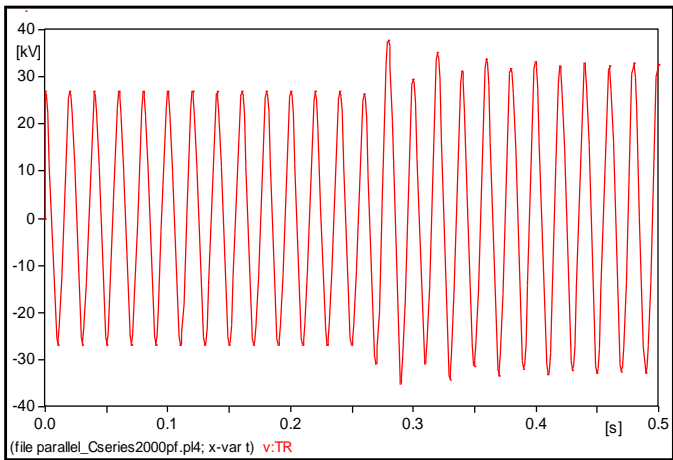

Figure 9 The output waveform for 1500pF series capacitor

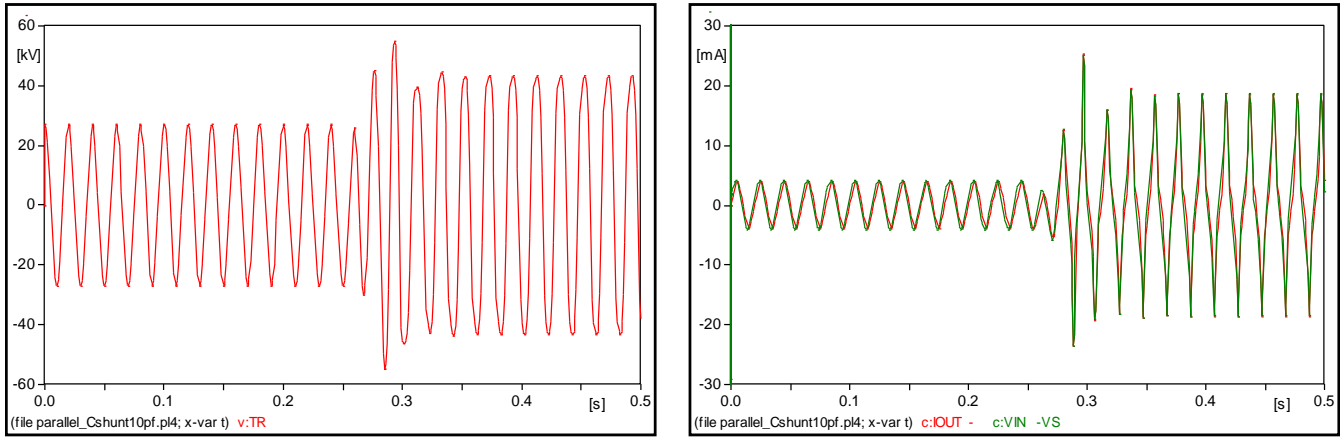

Figure 10 The output waveform for 40 pF shunt capacitor

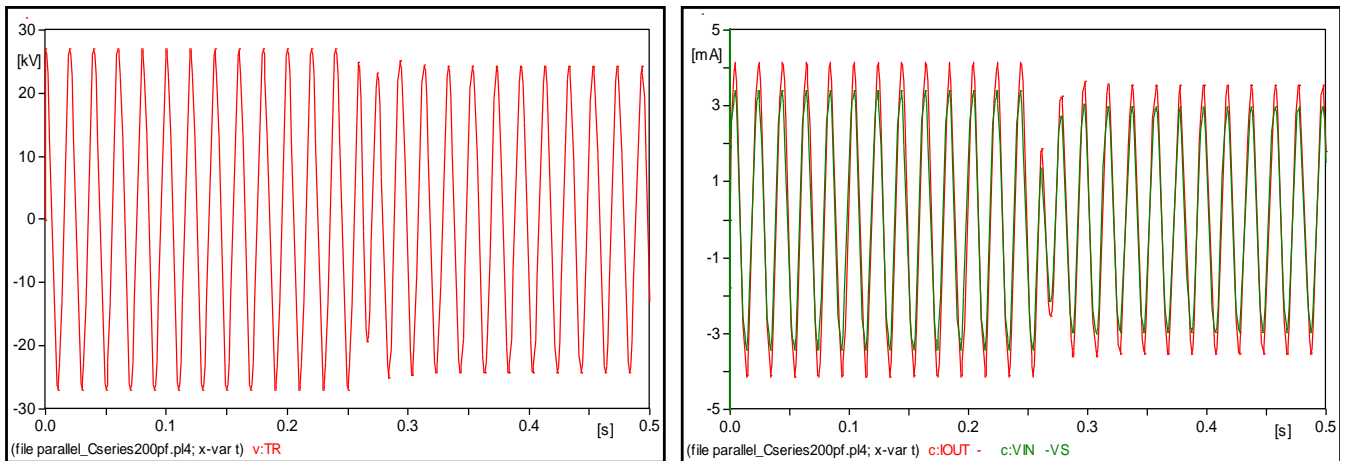

Figure 11 The output waveform for 400 pF shunt capacitor

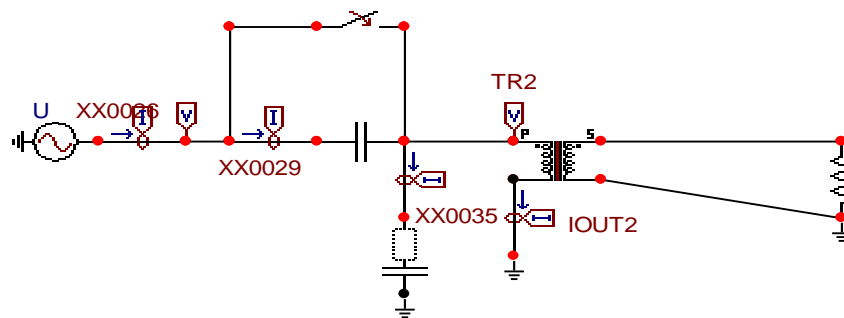

Figure 12 The simulation circuit with loading resistance

This is a quite well known method of preventing ferroresonance, in which the resistor acts as a damping element to the resonant phenomenon. Figure 12 shows the simulation circuit with a loading resistance at the voltage transformer secondary.

The simulated output waveforms, which would otherwise resonate in the absence of the load resistor, are clear in Figure 13. A load resistance value of 10 Ω was used for an example for getting the system behavior. It was observed that any load resistor value from 10 Ω to 100 Ω can be used to prevent ferroresonance. For the current configuration, the use of a higher value of load resistor cannot prevent ferroresonance from occurring.

5.2 Application of Linear Elements to the Primary

Linear components such as resistors or inductors can be connected to the voltage transformer primary to prevent or interrupt the ferroresonance phenomenon. A simulation was carried out by placing linear components in parallel with the VT model. It was observed that placing the linear component in series to the voltage transformer model helps in preventing ferroresonance.

5.2.1 Resistor

A resistor was placed in parallel to the voltage transformer in Figure 14. The analysis was carried out using smaller and larger values for the resistor. Table 7 summarizes the results, from which

it can be concluded that connecting a resistor parallel to the voltage transformer can mitigate ferroresonance.

After connecting different resistors to the VT, the peak voltage dramatically decreases from about 26 kV to around 4 kV when using 1 MΩ and from 26 kV to less than 0.1 kV after connecting a 100 Ω resistor in parallel to the VT.

5.2.2 Inductor

An inductance was placed in parallel to the voltage transformer in Figure 15. Table 8 summarizes the results, from which it is clear that connecting an inductor in parallel to the voltage transformer can stop the ferroresonance.

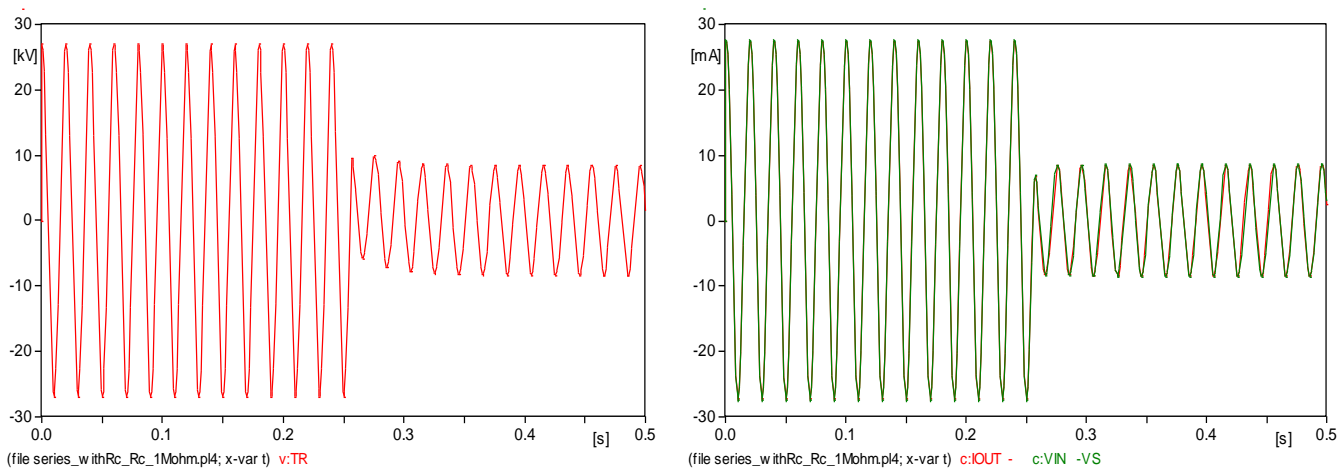

Figure 13 The simulated output waveforms with added secondary load resistance (10 Ω)

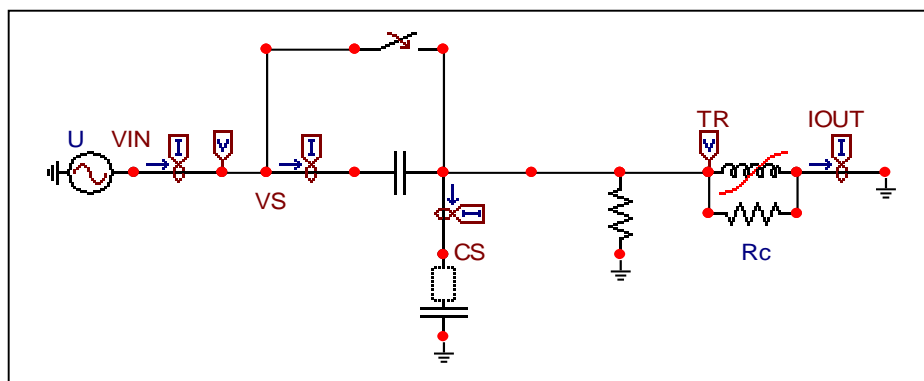

Figure 14 Applying Shunt Resistor

Table 7 The effect of connecting resistor parallel to voltage transformer

Resistor Value	Peak Voltage at Transformer (kV)		Peak Current at Transformer (mA)		Ferro-resonance Occur
	Before	After	Before	After	
1 MΩ	26.943	3.996	4.137	0.7313	No
100 Ω	26.943	0.08	4.134	0	No

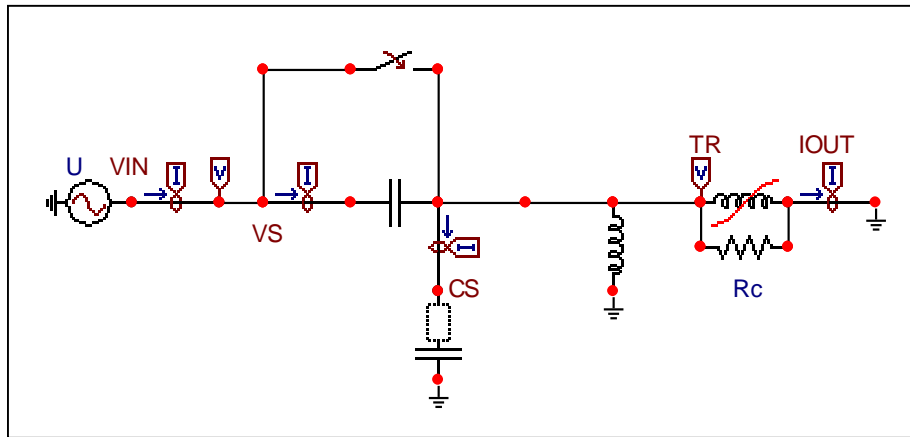

Figure 15 Applying Shunt Inductor

Table 8 The effect of connecting inductor parallel to voltage transformer

Inductance Value	Peak Voltage at Transformer (kV)		Peak Current at Transformer (mA)		Ferro-resonance Occurs
	Before	After	Before	After	
1 mH	26.943	0.0001	4.135	0	No
10 mH	26.943	0	4.137	0	No

6.0 DISCUSSION

Ferroresonance has been shown to be the result of specific circuit conditions, and can be induced predictably in the laboratory. Power system ferroresonance can lead to very dangerous and damaging overvoltages, but the condition can be mitigated or avoided by careful system design. Ferroresonance is triggered by system disturbances such as overvoltages due to lightning or switching surges, voltage transients, supply frequency variations, etc.

For the Kota Kemuning PMU in Malaysia, there was no record of lightning strikes nearby (from TNB Research lightning locating system data), nor were there reports of voltage transients immediately prior to the concerned VT failure. However, complete data for the system disturbances is not available and hence the possibility of ferroresonance occurring due to it cannot be totally eliminated.

Ferroresonant behavior typically consists of overvoltages and overcurrents whose waveforms are highly distorted, and which can last for seconds or tens of seconds. Based on the nature of ferroresonance failure, VTs may fail within a very short period of time. However, based on the remote event recorder and maintenance log at the PMU, there was no record of any switching activity immediately prior to the VT failure event. Nevertheless, there were records of outages and/or maintenance

carried out at the PMU which involved the concerned VT directly ever since the VT was commissioned.

7.0 CONCLUSION

From the present study it can be concluded that a C_{SERIES} of 500–1000 pF is required. However, the closest series capacitance made by the intercable capacitance is on the order of a few picofarads (estimated) and that made by the open circuited fuse is 0.03 pF (estimated). It can be concluded that there is no possibility of a C_{SERIES} of at least 500 pF through any means. Hence, it can be concluded that ferroresonance cannot be shown to have occurred at the VT due to switching operations since one precondition, namely the critical capacitance, could not have been satisfied.

Based on the simulation study, the following recommendations are made:

1. Installing load resistors on the secondary of the VT to damp out any ferroresonating condition.
2. Earth/ground the VT as soon as possible to avoid any ferroresonance from occurring during all switching operations.
3. Reconfigure the VT connection to a Delta–Y connection.

4. Provide overcurrent (fuse rating to be reviewed) and overvoltage protections (such as surge arresters) for the 33 kV VTs.
5. Consider the other causes of VT failure, such as harmonics and high excitation/magnetizing currents in the VT as well as the power transformers.

A possible cause of winding fault due to overcurrent could be the presence of harmonics in the system. This could either be due to the overall supply system's having a high harmonic content, or to the failed VT's being continuously operated beyond the linear section of its V–I characteristic. When this happens, the VT will behave like a nonlinear load. When magnetic saturation is reached the inductive reactance will decrease, resulting in high-peaked current to flow in the windings. Continuous operation in this high current condition may result in gradual weakening of the insulation level of the windings until failure eventually occurs.

Acknowledgement

Authors wish to thank Ministry of Science, Technology and Innovation and Institute of High Voltage & High Current of Universiti Teknologi Malaysia (Research Vote Nos. 4S004, 4S045, 00H41) and Tenaga Nasional Berhad, Malaysia (TNB Engineering and TNB Distribution).

References

- [1] Yu Kwong Tong. 2001. Ferroresonance Experience in UK: Simulations and Measurements, The IPST Conference.
- [2] Abdul-Malek Z. 2008. Simulation Study on Ferroresonance Phenomenon and Its Likely Cause for 33kV Voltage Transformer Failures. SCORED2008, Johor Bahru.
- [3] Abdul-Malek, Z., Mehranzamir, K., Salimi, B., Mirazimi, S. J. 2012. Investigation on the Probability of Ferroresonance Phenomenon Occurrence in Distribution Voltage Transformers Using ATP Simulation. *Advances in Intelligent Systems and Computing*, Chennai, India, Springer-Verlag, Berlin. 182.
- [4] Barbisio, E., Bottauscio, O., Chiampi, M., Crotti, G., Giordano, D. 2008. Parameters Affecting Ferroresonance in LCR Electric Circuits. *Magnetics, IEEE Transactions*. 44(6): 870–873.
- [5] Jacobson, D. A. N. 2003. Examples of Ferroresonance in a High Voltage Power System. *Power Engineering Society General Meeting, 2003, IEEE*. 2(4): 2666.
- [6] Mork, B. A. 1999. Five-legged Wound-core Transformer Model: Derivation, Parameters, Implementation and Evaluation. *Power Delivery, IEEE Transactions*. 14(4): 1519–1526.
- [7] Santoso, S., Dugan, Roger C., Nedwick, P. 2001. Modeling Ferroresonance Phenomena in an Underground Distribution System. The IPST Conference.
- [8] Picher, P., Bolduc, L., Girard, B. 2006. Mitigation of Ferroresonance Induced by Single-Phase Opening of a Three-Phase Transformer Feeder. Canadian Conference on Electrical and Computer Engineering, 2006. CCECE '06. 482–485.
- [9] Rezaei-Zare, A., Mohseni, H., Sanaye-Pasand, M., Farhangi, S., Irvani, R. 2006. Performance of Various Magnetic Core Models in Comparison with the Laboratory Test Results of a Ferroresonance Test on a 33 Kv Voltage Transformer. *Power Engineering Society General Meeting*.
- [10] Piasecki, W., Florkowski, M., Fulczyk, M., Mahonen, P., Nowak, W. 2007. Mitigating Ferroresonance in Voltage Transformers in Ungrounded MV Networks. *IEEE Transactions on Power Delivery*. 22(4): 2362–2369.
- [11] Moses, P. S., Masoum, M. A. S. 2010. Experimental and Simulation Analysis of Ferroresonance in Single-phase Transformers Considering Magnetic Hysteresis Effects. *Power and Energy Society General Meeting, 2010 IEEE*. 1–6.