

# Data Transmission System of Rotating Electric Field Mill Network Using Microcontroller and GSM Module

Zainuddin Nawawi<sup>b</sup>, Muhammad Abu Bakar Sidik<sup>a,b\*</sup>, Mook Boon Kean<sup>a</sup>, Hussein Ahmad<sup>a</sup>, Zolkafle Buntat<sup>a</sup>, Noor Azlinda Ahmad<sup>a</sup>, Muhammad 'Irfan Jambak<sup>b</sup>

<sup>a</sup>Institute of High Voltage And Current (IVAT) and Faculty of Electrical Engineering, Universiti Teknologi Malaysia, 81310 Johor Bahru, Johor, Malaysia

<sup>b</sup>Department of Electrical Engineering, Faculty of Engineering Universitas Sriwijaya 30662 Indralaya, Ogan Ilir, South Sumatera, Indonesia

\*Corresponding author: abubakar@fke.utm.my

## Article history

Received :15 February 2013

Received in revised form :

10 June 2013

Accepted :16 July 2013

## Graphical abstract



## Abstract

Lightning is an environmental phenomena that cause many fatalities and property destructions in Malaysia since the country is located in the high isokeraunic area. To reduce the fatalities an alert system should be developed. The alert system can consist of several Rotating Electric Field Mill sensors which are installed in spread. Data from the sensors must be gathered in a data centre building for observation, analysis, and triggering an alert signal. Therefore, the objective of this work is to develop a data transmission system by using a wireless method. The wireless data transmission system consists of a microcontroller, voltage divider, and GSM module. Hardware and software development is carried out to achieve the objective. Furthermore, to test the transmission system a function generator is connected to the analog digital converter input of the microcontroller. By varying the magnitude of the function generator output an observation on data transmission is carried out. It is found that the magnitude of receiving data which is displayed on the website is exactly the same with the sent data. In here in lab wireless data transmission system devices and a website to observe the transmitted data from Rotating Electric Field Mill sensors has been successfully developed.

*Keywords:* Lightning; electromagnetic field; wireless sensor networks

## Abstrak

Kilat adalah fenomena alam sekitar yang menyebabkan banyak kematian dan kemusnahan harta benda di Malaysia memandangkan negara ini terletak di kawasan isokeraunic tinggi. Untuk mengurangkan kadar kematian satu sistem amaran harus dibangunkan. Sistem amaran boleh terdiri daripada beberapa pengesan Rotating Electric Field Mill yang dipasang secara tersebar. Data dari sensor mesti berkumpul di sebuah bangunan pusat data untuk pemerhatian, analisis, dan mencetuskan isyarat amaran. Oleh itu, objektif kajian ini adalah untuk membangunkan satu sistem penghantaran data dengan menggunakan kaedah wayarles. Sistem penghantaran data wayarles terdiri daripada pengawal mikro, pembahagi voltan, dan modul GSM. Peranti keras dan pembangunan perisian dijalankan untuk mencapai matlamat tersebut. Selanjutnya, untuk menguji sistem penghantaran sebuah penjana fungsi disambungkan kepada analog input penukar digital pengawal mikro. Dengan mengubah magnitud pada keluaran penjana fungsi pemerhatian penghantaran data dijalankan. Ia didapati bahawa magnitud data yang dipaparkan di laman web adalah sama dengan data yang dihantar. Di sini di dalam makmal peranti sistem penghantaran data secara wayarles dan laman web untuk memerhatikan data yang dihantar dari Rotating Electric Field Mill sensor telah berjaya dibangunkan.

*Kata kunci:* Kilat; medan elektromagnet; rangkaian sensor wayarles

© 2013 Penerbit UTM Press. All rights reserved.

## 1.0 INTRODUCTION

The lightning strikes are identified as one of the most important causes of death, injury and damage to property due to environmental phenomena. Malaysia is a country with high atmospheric humidity and solar heating, which results in a higher lightning strike density. Kuala Lumpur, the country's capital city,

is ranked fifth in the world for lightning strike density [1]. Furthermore, a typical lightning strike is able to last more than one second, and plenty of discharges will occur within that second. Therefore, both electrical and magnetic induction will occur, even at a significant distance from the strike location [2]. Magnetic coupling from a lightning strike can induce high voltage surges in conductors and cause damage to electrical devices. The electrical

fields generated before a lightning strike can rise to approximately 500 kV/m within a 100 m range of a strike [3].

Thus a specialized device, for instance a Rotating Electric Field Mill (REFM), is needed to measure the atmospheric electric field and to predict the development of a lightning storm. REFM is an electro-mechanical device that measures the relative strength of an electric static field.

An REFM sensor will, normally, be installed in an open area far from the data centre building. For that reason, in order to collect, record and analyse the magnitude of an atmospheric electric field from the REFM sensor a transmission system is required to send the data.

There are two main types of data transmission method, which are wired and wireless. For this work, wireless had been selected over wired technology due to the potential range of coverage and its mobility. Since most sensors are located far apart in remote areas, a global system for mobile communication (GSM) is the most suitable technology to be applied.

GSM networks have been on the market for a long time, offer a variety of features and have more than 5 billion users, more than 80% of the earth’s population [4,5]. In addition, GSM offers low cost ownership and worldwide coverage, as this technology has been in existence for more than 20 years [5]. However GSM has several shortcomings, it is unable to concurrently transmit and receive data, and possesses unsatisfactory real-time ability [6].

With the shortcoming of the 2G network, it further developed into 2.5G, which is the GPRS network. GPRS is a packet data technology based on GSM that supports both the Point-to-Point Protocol (PPP) and Internet Protocol (IP). It provides a shorter time for internet service provider connections and charging is based on the amount of data sent rather than the connection time. With added packet-switching protocols, it will break up voice or data information into packets which are then only a few kilobytes each. Then, based on the addressing data within the packet, the information will be routed by the network between different destinations. Compared to GSM, GPRS has a high transmission rate, the ability to transfer real-time data, supporting IP, and has the ability to access the internet [7].

Therefore, in this paper a wireless network data acquisition system using GPRS is developed. GPRS has a high transmission rate and the ability to transfer real-time data [6]. By using this technology, data collected from remote sensors can be transmitted to a computer in a data centre that is connected to the internet with a fixed IP address.

The objectives of this research are to develop an interface between a REFM sensor and GSM module, as well as to develop a database system and observation website.

**2.0 HARDWARE AND SOFTWARE DESIGN**

The hardware arrangement for the data transmission is shown in Figure 1. The analogue output of the REFM sensor is connected to the Analogue output to Digital (A/D) converter input of the microcontroller (PIC 16F877A) [8]. After which, between the microcontroller and GSM module (SIM300), a voltage driver (IC MAX232) should be located since the working voltage of the two hardwares are different [9]. The microcontroller’s working voltage is 5 V (CMOS signal), whilst the GSM module’s working voltage is 12 V (RS232 signal). The connection for the MAX232 voltage driver is shown in Figure 2 [10].

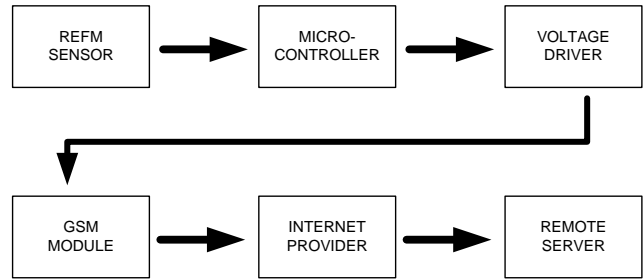

Figure 1 Block diagram of the system

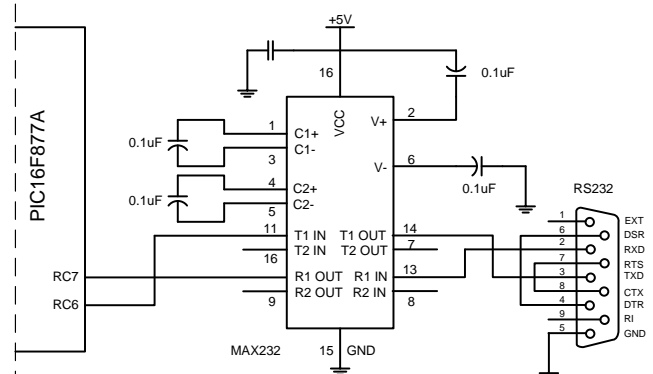

Figure 2 Connection between microcontroller and serial lines.

Finally, through the internet provider’s system the data will be transmitted to a PC (remote server) in the data centre. Here, the range of the wireless transmission system will be within the coverage of the GSM signal provider – which is able extend a few hundred or thousand kilometres – anywhere around the globe. In this work, four units of a REFM Data Transmission System (Datsys) have been developed in order to collect data on the atmospheric electric field from four stations. Each station will have their own set of hardware – consisting of a REFM sensor, microcontroller, IC MAX232, and GSM module.

All the microcontrollers used in this work have a LCD screen display incorporated. The main function of the LCD display is to show the status of the GSM module and identify whether the connection is successful or has failed. The complete set of connections for the 4 (four) REFM Datsys units is shown in Figure 3.



Figure 3 Four REFM data transmission system

The project software is mainly focused on the programming of the hardware, which sends instructions to the PIC microcontroller and GSM module so that the hardware is able to execute the system automatically.

In the early stages of software development, MPLAB IDE would be trained by running it with C programming language. By using C language, the necessary resources, which are the I/O ports, timers, USART module, and the initialisation of the LCD, were configured [8,11,12]. Further programming would be done by sending the AT commands to the GSM module – AT means attention. AT commands are standardised coding used to control a modem [13].

The program flowchart of the microcontroller to the GSM module is as shown in Figure 4. Initially, when the programs start to run, each module, the microcontroller and GSM modules, had to be initialised by sending AT commands to the GSM module and the GSM module would reply with its status to the PIC microcontroller. It concerned the transmitting and receiving progress which occurs between these two pieces of hardware. Fig. 4 below presents the programming code for the initialisation process.

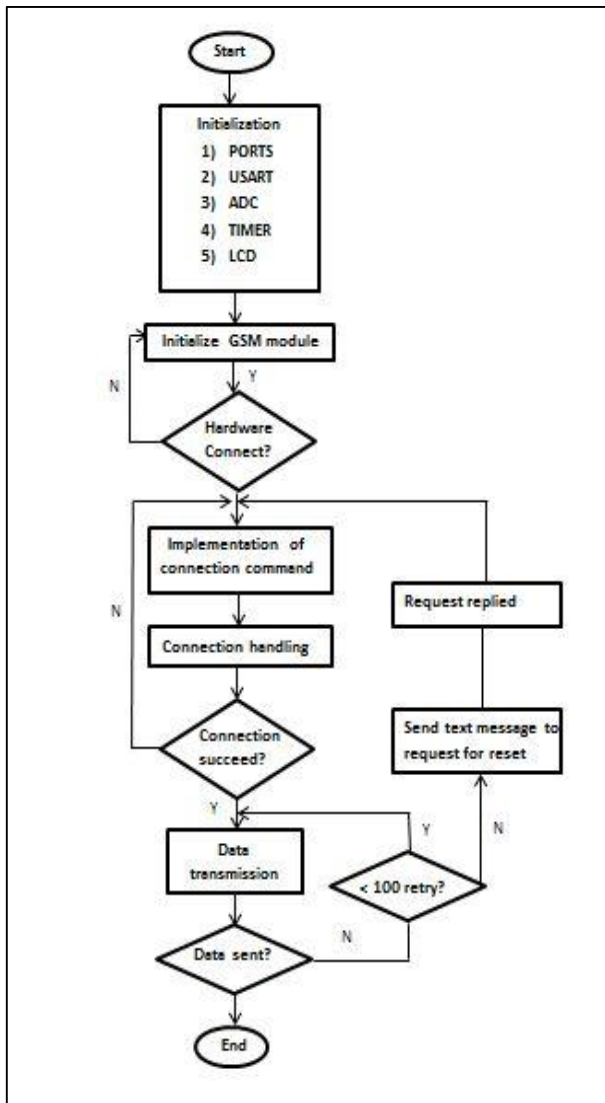

Figure 4 Process flowchart

Besides hardware programming, another programming is required for the webserver which provides to the users an access data collected from the sensors. MySQL, a relational database management system, was configured so that data sent from the GSM module would be stored in the database. Then the programming language Hypertext Preprocessor, PHP, was used to generate web content in the web server. As shown in Figure 5, PHP was inserted between the MySQL and web browser, and when there was a page request from the web browser it would be used to fetch the data stored in the MySQL database [14]. Then it would send out the data dynamically as an HTML page for the web browser, so that users could read the collected data.

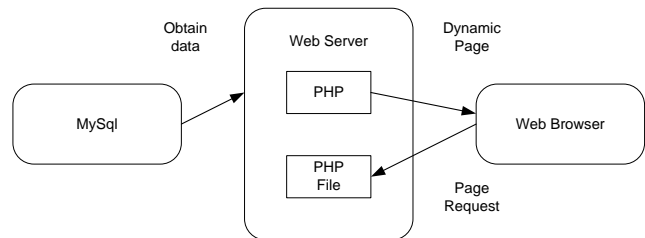

Figure 5 Access diagram using PHP

### 3.0 RESULT AND DISCUSSION

The baud rate of the microcontroller can be obtained by using the following equation [8]:

$$\text{Baud Rate} = \text{Fosc} / (16(X+1)), X = \text{value in SPBRG} \quad (1)$$

After calculating the X value, it will be included in the C program so that the proper baud rate is set for the microcontroller. By setting the correct baud rate for the microcontroller and GSM module interface, the data transmission is able to progress at the optimum rate, and the maximum communication speed set to 115,200 bps. Throughout the whole implementation of the project, the main concern is establishing access to the internet by using the GPRS network, so that the data can be transmitted wirelessly from the EFM sensor to the remote server. A GSM module with GPRS functions and a SIM card that has GPRS services available are essential. Then the communication protocol between them will be an AT command. A portion of the AT commands used to facilitate the connection are shown in Table 1, the other AT commands can be found in [13].

Then the experimental results which is stored in the MySQL database is displayed as a PHP page, as shown in Fig. 6. This allows users to observe and analyse the real time key information.

Further, the REFM Datsys will be attached to the REFM sensor and installed in particular locations. The developed REFM sensor consists of a rotating-vane, sensor plate, and 12 V DC motor. Both of the rotating-vane and sensor plate are identical. A unique coupling was designed to fasten the rotating-vane at the motor shaft. The components – rotating-vane, sensor plate, and coupling – are made of stainless steel.

The output signal magnitude of the developed REFM sensor is in millivolt and distorted. In order to obtain a required output signal, the original signal from REFM sensor must be fed into a signal conditional unit which consists of amplification, filtering, and converting process.

A calibration work had to be done to obtain a correlation factor between the input signal magnitude of REFM sensor and the output signal magnitude of the signal conditioning unit. In order that a

calibration setup needed to be prepared. A detail explanation on the developed REFM sensor can be obtained in the previous work [15].

**Table 1** AT commands

AT+CGATT=1	This command indicates the state of the GPRS attachment, where the value '1' results in the activation of the GPRS function. Once it responds with 'OK' the GPRS connection is established, else a response of 'ERROR' is received showing that the connection has failed.
AT+CDNSORIP=1	Sets the connection with IP address server or domain name server. Selecting a value '1' indicates the selection of the remote server as the domain name.
AT+CIPSTART='TCP', 'domain name', '80'	The setting 'TCP' establishes a TCP connection and the 'domain name' is the user's remote server domain name. The value '80' is the remote server port selected, and this port value is the server port for the Hypertext Transfer Protocol (HTTP).
AT+IPR=115200	This command manually sets the baudrate of the GSM module.

ID	StationId	Magnitude	Timestamp
71	ST03	2.065	Mon, 21 May 2012 17:52:57 +0800
70	ST04	2.114	Mon, 21 May 2012 17:52:48 +0800
69	ST02	2.343	Mon, 21 May 2012 17:52:16 +0800
68	ST03	2.109	Mon, 21 May 2012 17:52:07 +0800
67	ST04	2.094	Mon, 21 May 2012 17:51:49 +0800
66	ST04	2.099	Mon, 21 May 2012 17:50:49 +0800
65	ST04	2.08	Mon, 21 May 2012 17:49:48 +0800
64	ST01	2.309	Mon, 21 May 2012 17:49:40 +0800
63	ST04	2.075	Mon, 21 May 2012 17:48:48 +0800
62	ST01	2.109	Mon, 21 May 2012 17:48:40 +0800

**Figure 6** Part of output of the function generator as shown in webpage

#### 4.0 CONCLUSION

This paper has presented the development process of a wireless data transmission system that will be used for a REFM sensor network. The wireless transmission system device has permitted real-time data acquisition from remote REFM sensor locations. All the information about the atmospheric electrical field condition sensed by the REFM sensors will be stored in a database system, which can be monitored online through the developed website.

#### Acknowledgement

The authors gratefully acknowledge the support extended by Ministry of Higher Education (MOHE), Malaysia and Universiti Teknologi Malaysia on the Research University Grant (RUG), No. Q.J130000.2623.01J95 to carry out this work.

#### References

- [1] National Lightning Safety Institute (NLSI).
- [2] [http://www.lightningsafety.com/nlsi\\_info/world-lightning-activity.html](http://www.lightningsafety.com/nlsi_info/world-lightning-activity.html). Access on May 2012.
- [3] John Wiley & Son. 2011. Reliability Technology: Principles and Practice of Failure Prevention in Electronic System. Wiley 1 edition. 5-44–5-45.
- [4] Mark I. Montrose, Edward M. Nakauchi. 2004. Testing for EMC Compliance: Approaches and Techniques. 175–176.
- [5] GSM Association. GSM World Statistics. Retrieved 8 June 2010.
- [6] Eugen Horatiu Gurban and Gheorghe-Daniel Andreescu. 2011. SCADA Element Solutions using Ethernet and Mobile Phone Network. IEEE 9th International Symposium, September.
- [7] Hong Cai. 2009. A Remote Wireless Data Acquisition System Based on Ad Hoc Network and GPRS. 2009 Second International Workshop on Computer Science and Engineering, IEEE.
- [8] Xiang-Yang Li. 2003. *Wireless Ad Hoc and Sensor Networks theory and Applications*. Cambridge Book Online, Cambridge University Press.
- [9] Microchip Technology Inc. PIC16F87XA Data Sheet.
- [10] Nobbert Stuban. 2004. Wireless Data Transmission between Personal Computers. IEEE 27th Int'l Spring Seminar.
- [11] Maxim Integrated Products. 2010. +5V-Powered, Multichannel RS-232 Drivers/Receivers.
- [12] Microchip Technology Inc. 2009. MPLAB C Compiler For PIC32 MCUs User's Guide.
- [13] Jivan S. Parab, Vinod G. Shelake, Rajanish K. Kamat and Gourish M. Naik. 2007. Exploring C for Microcontrollers. Springer.
- [14] SIMCOM Limited. 2004. SIM300 AT Commands Set. version 01.03.
- [15] Muhammad Abu Bakar Sidik. 2008. Lightning Air Terminal Enhancement Based on Charge Generation. PhD Thesis of Universiti Teknologi Malaysia.