

Effect of Mesh Number on Accuracy of Semi Submersible Motion Prediction

Hassan Abyn^{a*}, Adi Maimun^b, M. Rafiqul Islam^c, Allan Magee^d, Jaswar^a, Behnam Bodaghi^a, Mohamad Pauzi^b, C. L. Siow^a

^aDepartment of Aeronautic, Automotive and Ocean Engineering, Faculty of Mechanical Engineering, Universiti Teknologi Malaysia, 81310 UTM Johor Bahru, Johor, Malaysia

^bMarin Technology Center, Universiti Teknologi Malaysia, 81310 UTM Johor Bahru, Johor, Malaysia

^cBangladesh University of Engineering and Technology, Dhaka, Bangladesh

^dTechnip Malaysia

*Corresponding author: abynhassan@gmail.com

Article history

Received :1 August 2013

Received in revised form :

10 November 2013

Accepted :28 November 2013

Graphical abstract

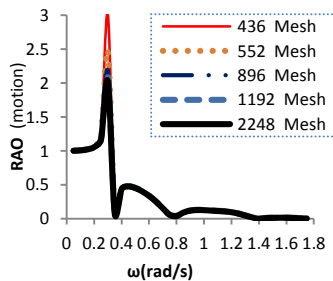

Abstract

Generally, floating structures play an important role for exploring the oil and gas from the sea. The force and motion prediction of offshore structures may be carried out by using time domain or frequency domain or model tests. In this paper the frequency domain analysis used because it is the simplified and linearized form of the equations of motion. Mostly in numerical calculations the number of meshes plays an important role in the accuracy of results, time of calculation and facing to computer memory limitations. The 3D source distribution panel method is shown to be sensitive to mesh near the resonance frequencies of the floating body. So, it is important to establish best practices and determine the mesh requirements for a given level of accuracy. The results obtained from numerical commercial software HydroSTAR (Hstar) on semi submersible prove it.

Keywords: Semi submersible; floating structures; 3D source density distribution technique; potential theory; mesh generation

© 2014 Penerbit UTM Press. All rights reserved.

1.0 INTRODUCTION

All of fixed, floating and moored structures such as ship, semi-submersible, FPSO, TLP and others are subjected to wave, wind and current at sea. They have six-coupled degrees of freedom of motions. Namely, linear and angular motions are surge, sway, heave, roll, pitch and yaw. Oscillating of floating structure affects the loading and offloading operation systems. They may experience resonant motions, which should be avoided as much as possible under installation, operation and survival conditions. In particular, the vertical plane motions induced by heave, roll and pitch of a floating structure should be kept adequately low to guarantee the safety of risers and umbilical pipes as the most important components in the equipment of oil production.

There are different theories for studying motion of floating structure such as strip theory and potential theory. 3D source density distribution technique is used to get the potential over the floating structure by many researchers and softwares. Having flow velocity potentials on and off the panels, hydrodynamic coefficients of floating structure can be determined. Using Bernoulli's equation leads to calculation of pressure distribution and forces over the floating structure. A numerical model is a mathematical structure which can be used to describe and study a

real situation. A second-order linear differential equation for coupled six degree of freedom can describe the hydrodynamics of floating structures; consist of added mass, damping coefficient, stiffness coefficient, forces and motions in six directions.

Hess and Smith¹ studied on non-lifting potential flow calculation about arbitrary 3D objects. They utilized a source density distribution on the surface of the structure and solved for distribution necessary to lake the normal component of the fluid velocity zero on the boundary. Plane quadrilateral source elements were used to approximate the structure surface, and the integral equation for the source density is replaced by a set of linear algebraic equations for the values of the source density on the quadrilateral elements. By solving this set of equations, the flow velocity both on and off the surface was calculated.

Wu, *et al.*² studied on the motion of a moored semi submersible in regular waves and wave induced internal forces numerically and experimentally. In their mathematical formulation, the moored semi submersible was modeled as an externally constrained floating body in waves, and derived the linearized equation of motion.

Yilmaz³ analyzed the excessive motion of moored semi submersible. They developed and employed two different time domain techniques as due to mooring stiffness, viscous drag forces

and damping; there are strong nonlinearities in the system. In the first technique, first-order wave forces acting on structure considered as a solitary excitation forces and evaluated according Morison equation. In their second technique, they used mean drift forces to calculate slowly varying wave forces and simulation of slowly varying and steady motions

Söylemez⁴ developed a technique for prediction of damaged semi submersible motion under the wind, current and wave. He used Newton’s second law for resolving equations of motion and developed numerical techniques of nonlinear equations for the intact and damaged condition in time domain.

Clauss , *et al.*⁵ analyzed numerically and experimentally the sea-keeping behavior of a semi submersible in rough waves in the North Sea. They used panel method TiMIT (Time-domain investigations, developed at the Massachusetts Institute of Technology) for wave/structure interactions in time domain. The theory behind TiMIT is strictly linear and thus applicable to moderate sea condition only.

Newman⁶ carried out convergence studies using WAMIT in the frequency domain for representative floating bodies using different discretization schemes.

An important requirement for a unit with drilling capabilities is the low level of motions in the vertical plane (motions induced by heave, roll and pitch. Matos, *et al.*⁷ numerically and experimentally investigated Second-order resonant of a deep-draft semi-submersible heave, roll and pitch motions. One of the manners to improve the hydrodynamic behavior of a semi-submersible is to increase the draft. The low frequency forces computation has been performed in the frequency domain by WAMIT a commercial Boundary Element Method (BEM) code. They generated a different number of meshes on the structure and calculated pitch forces (

Figure 7).

This study focuses on vertical motion of GVA 4000 semi submersible which is characterized by favorable sea-keeping behavior and calculates motion of a body at Head and Beam Sea for different number of meshes.

2.0 THEORY AND MATHEMATICAL MODELING

The individual semi submersible is treated as a rigid body with six degrees of freedom (

Figure 1). It is subjected to hydrodynamic forces due to sea incident waves, radiated wave by itself and diffracted waves due to itself as well as bodies. Two right hand coordinate systems are defined. One is fixed to the space on water surface and the other one is fixed to the center of gravity.

The fluid is assumed to be incompressible, inviscid and irrotational and the vessel is assumed to be floating in open water. Then velocity potential with boundary condition of the structure, water free surface, sea bottom and far field are considered to satisfy the Laplace equation. Time dependence of fluid motion is limited to simple harmonic motion, so the flow field can be characterized by the following velocity potential:

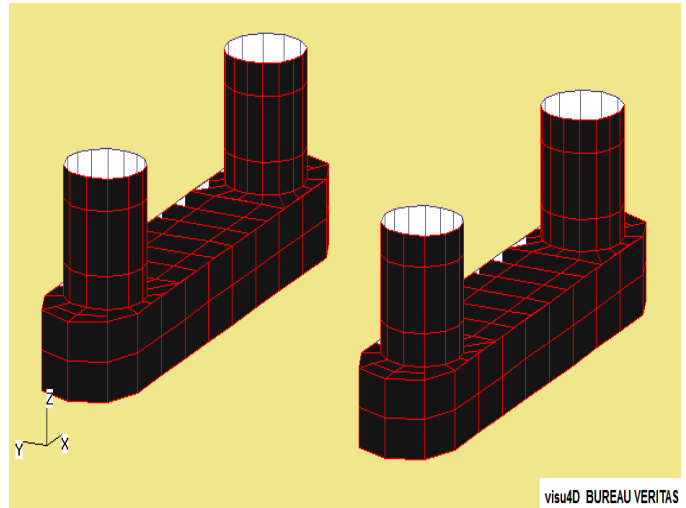

Figure 1 Semi submersible wetted surface

$$\Phi = Re[\phi(x, y, z)e^{i\omega t}] \tag{1}$$

$$\phi = -i\omega \left[(\phi_0 + \phi_7) \cdot \zeta_a + \sum_{j=1}^6 (X_j \phi_j) \right] \tag{2}$$

$$\phi_0 = -\frac{ig\zeta_a \cosh[k(z+h)]}{\omega \cosh kh} e^{ik(x\cos\alpha + y\sin\alpha)} \tag{3}$$

The differential equation governing the fluid motion follows from the application of the continuity equation which yields the Laplace equation. The individual potentials are the solutions of the following Laplace equation:

$$\nabla^2 \phi = 0 \tag{4}$$

2.1 Boundary Condition

In the fluid domain bounded by the mean wetted surface area of body S, the above linear velocity potentials must satisfy the Laplace equation and also the following boundary conditions:

-linearized free surface condition:

$$\frac{\partial \phi}{\partial z} + \frac{\omega^2}{g} \phi = 0, \text{ at } z=0 \tag{5}$$

-boundary condition on the sea floor:

$$\frac{\partial \phi}{\partial z} = 0 \text{ on } z = -h \tag{6}$$

Another boundary condition is the wetted surface of the floating structures. Because of linearization, mentioned boundary condition may be applied on the wetted surface of the floating structure in its equilibrium position

$$\frac{\partial \phi_0}{\partial n} + \frac{\partial \phi_7}{\partial n} = 0, \text{ on } S \tag{7}$$

$$\frac{\partial \phi_j}{\partial n} = -i\omega n_j, \text{ on } S \tag{8}$$

In which n_j is the direction cosine on the surface of the body in the j -th mode of motion and has the following form:

$$\begin{aligned} n_1 &= \cos(n, x), & n_2 &= \cos(n, y), & n_3 &= \cos(n, z) \\ n_4 &= (y - y_G)n_1 - (z - z_G)n_2 \\ n_5 &= (z - z_G)n_1 - (x - x_G)n_3 \end{aligned}$$

$$n_6 = (x - x_G)n_2 - (y - y_{z_G})n_1$$

The radiation condition of the potentials ϕ_j , in which in polar co-ordinate:

$$\lim_{r \rightarrow \infty} \left(r^{\frac{1}{2}} \left(\frac{\partial \phi}{\partial r} - \frac{i\omega^2}{g} \phi \right) \right) = 0 \tag{9}$$

2.2 Velocity Potential

However, there is no analytical solution for ϕ_7 and ϕ_i , so the problem should be solved numerically. According to the 3-D sink source method, the potentials ϕ_7 and ϕ_i can be expressed in terms of well known Green functions that can be expressed by the following equation⁸.

$$\phi_j(x, y, z) = \frac{1}{4\pi} \sum_{j=1}^6 \iint \sigma(\xi, \eta, \zeta) G(x, y, z, \xi, \eta, \zeta) ds \tag{10}$$

The integral is to be carried out over complete immersed surface of the object. The Green function G (source potential) must in order of the representation in (Equation (10)) to be valid, satisfy all the boundary conditions of the problem with the exception of the body boundary conditions and have a source like behavior. As a result, boundary conditions are reduced only to on wetted surfaces of the bodies. So, the wetted surfaces should be subdivided into panels to transform integral equations to a system of algebraic equations to determine unknown source density over each panel. The appropriate Green function used in this paper to the boundary value problem posed is given by Wehausen, *et al.*⁸ After getting the source density, the velocity potentials on each panel can be obtained using the (Equation (10)).

2.3 Forces and Moments

Once the velocity potential is obtained, the hydrodynamic pressure at any point on the body can be obtained from the linearized Bernoulli's equation and can be written as:

$$\frac{\partial \Phi}{\partial t} + \frac{1}{2} (\nabla \Phi)^2 + \frac{P}{\rho} + gz = 0 \tag{11}$$

Now after putting the value of Φ in the (Equation (11)), the following expression is obtained,

$$-\frac{P}{\rho} = -i\omega\phi + \frac{1}{2} (\nabla\phi)^2 + gz \tag{12}$$

By neglecting the higher order terms, we can write:

$$P = -\rho gz + i\rho\omega\phi \tag{13}$$

As first part of (Equation 13) is associated with the hydrostatic and steady forces, so neglecting this part, the first order wave exciting and oscillatory forces caused by the dynamic fluid pressure acting on the body can be obtained from the following integrals:

$$F_k e^{-i\omega t} = -i\rho\omega e^{-i\omega t} \int_S \{\phi_0 + \phi_7\} n_k ds \tag{14}$$

$$F_{kj} e^{i\omega t} = -\rho\omega e^{-i\omega t} \int_S \{\omega^2 \bar{X}_j \phi_j\} n_k ds \tag{15}$$

Moreover, it is usual to decompose the hydrodynamic forces resulting from the movement of the bodies into components in phase with the acceleration and velocity of the rigid body motions. It leads to the added mass and damping coefficients

respectively. These coefficients which are used in the equation of motion can be expressed from the equation as:

$$a_{kj} = -\rho \operatorname{Re} \left[\int_S \phi_j n_k ds \right] \tag{16}$$

$$b_{kj} = -\rho\omega \operatorname{Im} \left[\int_S \phi_j n_k ds \right] \tag{17}$$

The suffixes $k, j = 1, 2, 3, 4, 5, 6$ represent surge, sway, heave, roll, pitch and yaw modes, respectively.

2.4 Equation of Motion in Frequency Domain

By having exciting forces, added mass and damping coefficients, the motions of semi submersible can be calculated by the following coupled equations. The equation of motion will be coupled dynamically because of hydrodynamic interaction between the elements. So the equation can be considered by using the following matrix relationship:

$$\sum_{j=1}^6 (M_{kj} + a_{kj}) \ddot{X}_j + b_{kj} \dot{X}_j + CX_j = F_k \tag{18}$$

$k = 1, 2 \dots 6 \quad \& \quad j = 1, 2 \dots 6$

3.0 RESULTS AND DISCUSSION

One of the obstacles in numerical methods is mesh number, computer ram limitations and finally calculate time consumption. To obtain the motion responses of a floating semi submersible calculation has been carried out at Head and Beam Sea by using HydroSTAR⁹ which is commercial software based on potential theory. The principal particular of the selected Semi Submersible is showed in Table 1.

A different number of flat quadrilateral meshes 436, 552, 896, 1192 and 2248 have been generated on the wetted surface of semi submersible. It was tried to choose small meshes at the edges and near water surface for more accuracy (Figure 2). For more visibility of figures only half of the body was shown. The HydroSTAR itself was used to generate the meshes.

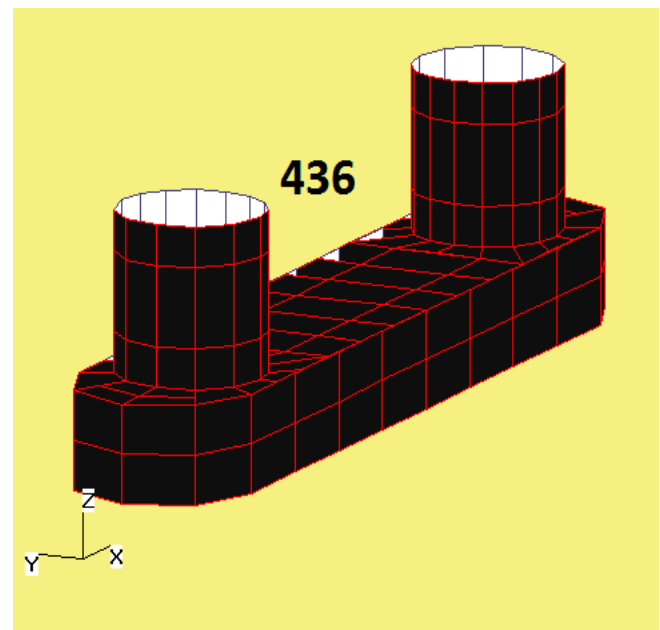

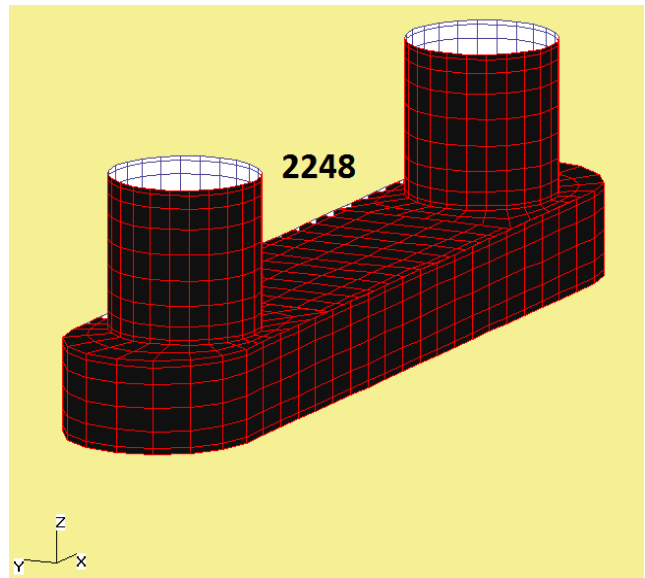
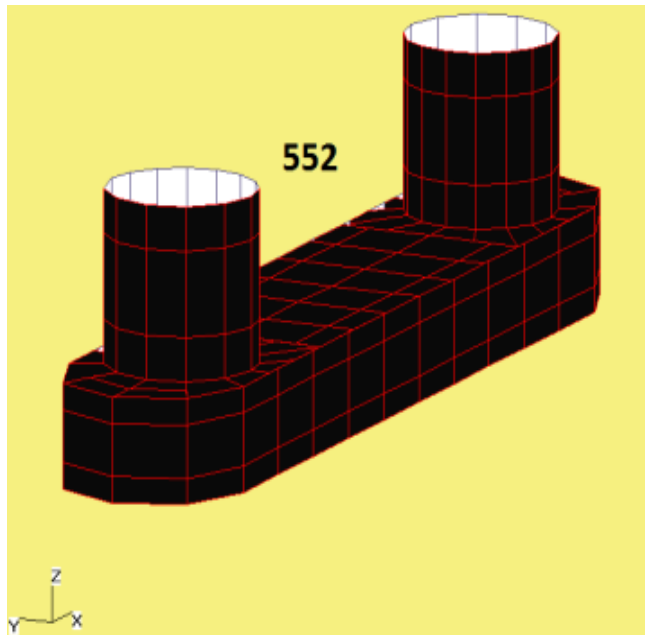

Figure 2 Wetted surface mesh

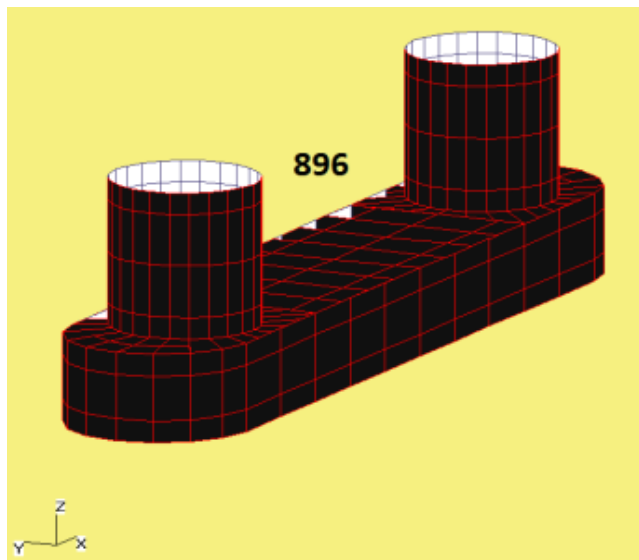

Table 1 Principal particular of the semi submersible

Character	Size	Unit
Length	66.78	m
Width	58.45	m
Draft	16.73	m
Displacement	14921	m ³
Water Plan Area	529.6	m ²
Number of Columns	4	
Pontoon depth	6.3	m
Pontoon beam	13.3	m
Pontoon centerline separation	45.15	m
Column longitudinal spacing (centre)	45.58	m
Column diameter	10.59	m
GM _T	2.87	m
GM _L	4.06	m
K _{XX}	31.64	m
K _{YY}	26.95	m
K _{ZZ}	35	m
CG _X	0	m
CG _Y	0	m
CG _Z	-0.28	m
ω_{n3}	0.32	rad/s
ω_{n4}	0.09	rad/s
ω_{n5}	0.12	rad/s

Computations of first order problem of wave diffraction and radiation have been carried out for motion responses of a semi submersible at Head Sea and Beam Sea and plotted against wave frequency in Figure 3-Figure 6 at a water depth of 175 meters.

Figure 3 and Figure 5 and shows non-dimensional heave motions at heading 90 and 180 respectively. The RAOs plateau around one until around 0.2 rad/s and after that get a maximum peak at resonant frequency 0.35 rad/s. In the range of natural frequency resonance takes place, so the calculation is difficult and strongly depends on the damping. Then they fell down dramatically to reach a nadir at the so-called cancellation frequency 0.38 rad/s. At the cancellation period, the vertical excitation on top and bottom of the pontoons reduces the exciting force to near zero. The RAOs then rise to reach the second peak about 0.5rad/s and finally slope down to zero at high frequencies.

In the roll motion RAO (Figure 4) the first peak occurs at around natural frequency 0.1 rad/s and second one at 0.65 rad/s. The RAO decreases from 0.61 to 0.02 at cancelling frequency 1.1

rad/s. The first peak takes place at 1.2 rad/s and after that the RAOs slope down. Figure 4 and 7 show that calculation in very low or high frequencies should be done at different meshes numbers.

In Figure 6 pitch motion RAOs reach a peak at natural frequency 0.12 rad/s, then drop at cancelling frequency 0.19 rad/s. There are rises of 0.4 at 0.6 rad/s and after that they decrease dramatically to reach 0.015 at 1.05 rad/s.

As the Figure 3-Figure 6 show, calculation results for different number of meshes are nearly identical (not sensitive to mesh), except at natural frequencies. Normally calculation accuracy is low at resonance frequency. The RAOs are highly dependent on damping and potential damping is low. So, more panels are required to give a converged result.

For verification Matos, *et al.*⁷ wave exciting pitch results which were calculated by using WAMIT shown in

Figure 7. As it shows the result in different mesh numbers excluding 241 panels, are almost same.

In this study calculation carries out by using Dell laptop, CPU 1.83 GHz, RAM 3 GB, Window 7, 64 bit operating system.

Figure 8 shows the calculation time by HydroSTAR for different mesh numbers of semi submersible. The mentioned time has been shown in percentage form in

Figure 9.

436 mesh and related calculation time considered as a base and the others computed respect for them. As it is shown by increasing mesh numbers almost 200% (2 times), calculation time increases about 500% (5 times) and increasing 400% cause 2000% of calculation time.

4.0 CONCLUSION

Motion of floating structure has significant influence on loading and unloading operation. In this paper, a semi submersible modeled in well-known commercial software HydroSTAR. A calculation has been carried out at the different number of meshes on the wetted surface of the structure and computation time recorded. Calculation time increases dramatically by increasing mesh number. For larger meshes, improved calculation times may be achieved using larger RAM to avoid swapping data to the hard disk.

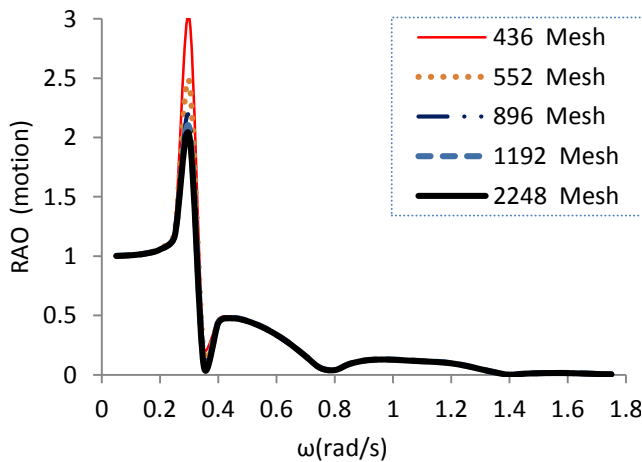

Figure 3 Heave motion (RAO) at beam sea

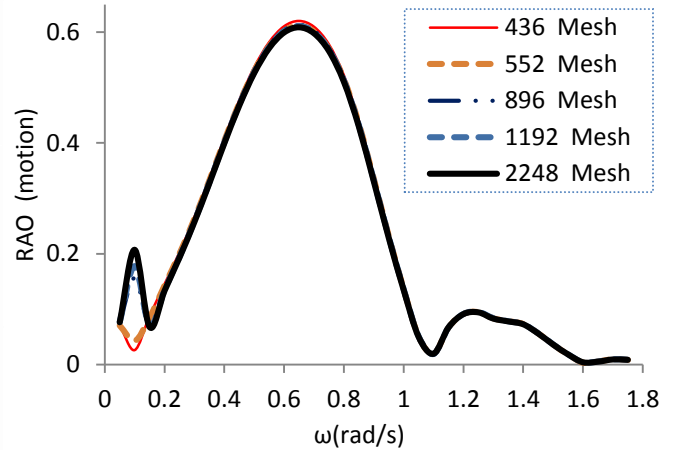

Figure 4 Roll motion (RAO) at beam sea

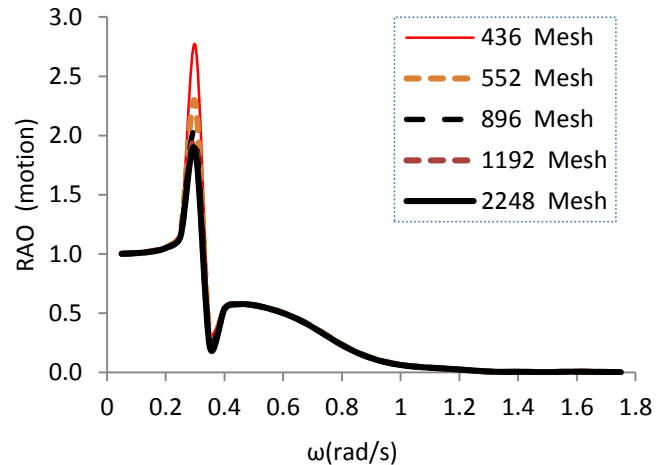

Figure 5 Heave motion (RAO) at head sea

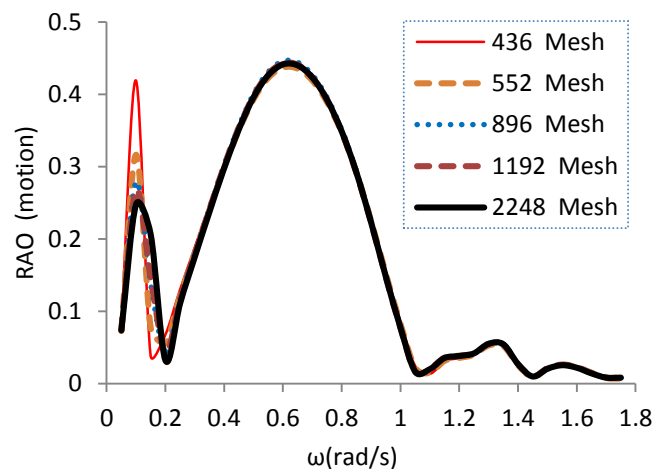

Figure 6 Pitch motion (RAO) at head sea

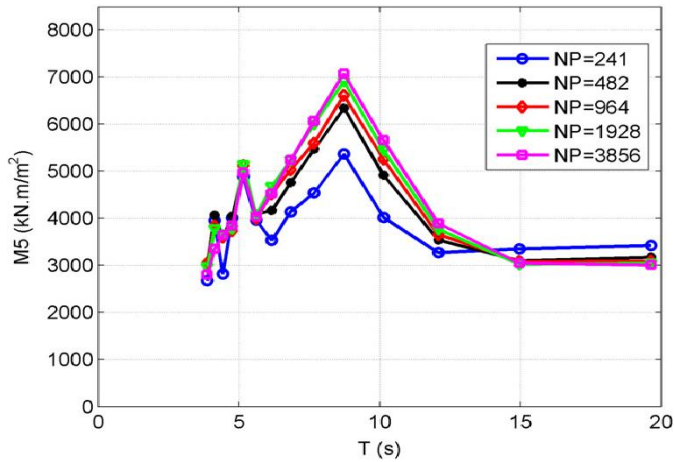

Figure 7 Pitch wave exciting forces ⁷

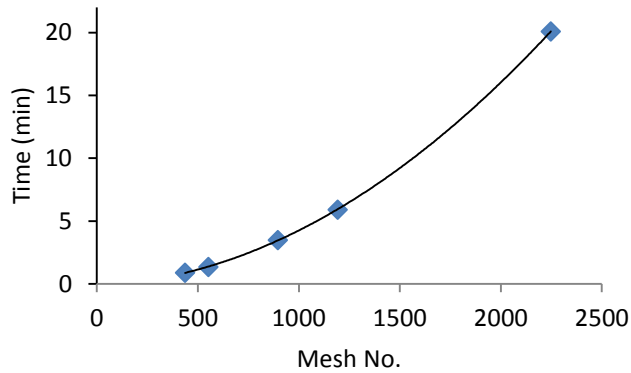

Figure 8 Calculation time for different mesh numbers

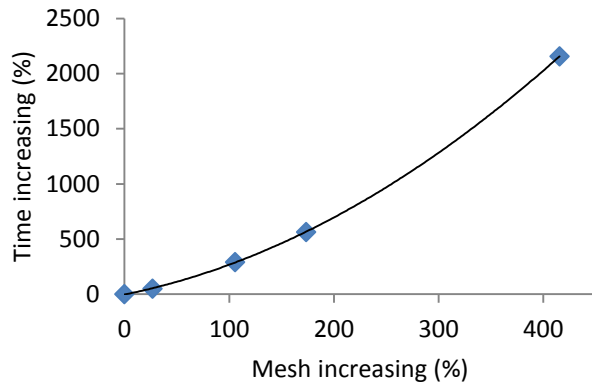

Figure 9 Calculation time in percentage form

Nomenclature

a_{kj}	Added mass coefficient matrix of kj
b_{kj}	Damping coefficient matrix of kj
BUET	Bangladesh University of Engineering and Technology
C	Hydrostatic restoring force coefficient matrix of kj
F_k	denotes the k -th component of wave exciting forces
F_{kj}	denotes the k -th component of force arising from the j -th component of motion of the body.
Fn	Froude number
g	Gravitational acceleration
M_{kj}	Inertia matrix in k mode due to the motion in j mode
RAO	Response Amplitude Operation
UTM	Universiti Teknologi Malaysia
x_G, y_G, z_G	Co-ordinate of the centre of gravity of the body
x, y, z	Investigating point on the wetted surface of the body
X_j	Vector containing the three translational and three rotational oscillations about the coordinate axes in j mode.
α	Wave heading angle from X -axis
ω	Circular frequency of incident wave
ζ_a	Incident wave amplitude,
ϕ_0	Incident wave potential
ϕ_7	Diffraction wave potential on body
ϕ_j	Potential due to motion of the body in j -th mode,
(ξ, η, ζ)	denotes a point on surface S
$\sigma(\xi, \eta, \zeta)$	denotes the unknown source distribution.

References

- [1] Hess, J. L. and A. M. O. Smith, 1964. Calculation of Nonlifting Potential Flow About Arbitrary 3D Bodies. *Journal of Ship Research*. 1(1): 22–44.
- [2] Wu, S., J. J. Murray, and G. S. Virk, 1997. The Motions and Internal Forces of a Moored Semi-submersible in Regular Waves. *Ocean Engineering*. 24(7): 593–603.
- [3] Yilmaz, O. and A. Incecik, 1996. Extreme Motion Response Analysis of Moored Semi-submersibles. *Ocean Engineering*. 23(6): 497–517.
- [4] Söylemez, M., 1995. Motion Tests of a Twin-hulled Semi-submersible. *Ocean Engineering*. 22(6): 643–660.
- [5] Clauss, G. F., C. Schmittner, and K. Stutz. 2002. Time-domain Investigation of a Semi Submersible in Rogue Waves. in 21st International Conference on Offshore Mechanics and Arctic Engineering (OMAE2002). Oslo, Norway: ASME.
- [6] Newman, J. N. *Progress in Wave Load Computations on Offshore Structures*. In OMAE 2004. 2004. Vancouver.
- [7] Matos, V. L. F., A. N. Simos, and S. H. Sphaier, 2011. Second-order Resonant Heave, Roll and Pitch Motions of a Deep-draft Semi-submersible: Theoretical and Experimental Results. *Ocean Engineering*. 38(17–18): 2227–2243.
- [8] Wehausen, J. V. and E. V. Laitone. 2002. *Surface Waves*. Berlin: Springer.
- [9] Chen, X.-b. 2010. *HydeoSTAR for exports - User Manual*.