

Extraction of Lignosulfonate using TOA-Kerosene-PVDF in Supported Liquid Membrane Process

Chen Ke Xian^a, Norasikin Othman^{a*}, Norlisa Harruddin^a, Nur Alina Nasruddin^a, Zing Yi Ooi^a

^aCenter of Lipids Engineering and Applied Research (CLEAR), Department of Chemical Engineering, Faculty of Chemical Engineering, Universiti Teknologi Malaysia, 81310 UTM Johor Bahru, Johor, Malaysia

* Corresponding author: norasikin@cheme.utm.my

Article history

Received :1 October 2013
Received in revised form :
19 December 2013
Accepted :27 January 2014

Graphical Abstract

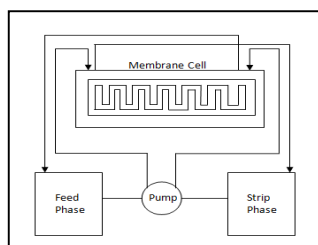

Abstract

Lignosulfonate is a major byproduct from the sulphite pulping process which is the most abundant biopolymer and largely unused. Although lignosulfonate is nontoxic, it impacts brownish black colour to water and makes the water unsuitable for reuse. However, lignosulfonate have a wide range application, such as production of vanillin, animal feed pellets binder and pesticides. Therefore, an efficient separation technique of lignosulfonate from the wastewater is necessary in order to meet the wastewater treatment requirement and as a source of valuable material for industrial applications. In this study, lignosulfonate was extracted from aqueous solution through flat sheet supported liquid membrane (SLM) using trioctylamine (TOA) as carrier. SLM has great potential for the separation lignosulfonate as it offers advantages such as simultaneous extraction and stripping steps, low consumption of carrier and high selectivity. The important parameters governing the extraction process are the types of support material, types of solvents, types of stripping agent, feed phase flow rate and pH were investigated. The favorable condition for extraction was obtained by using TOA-Kerosene-PVDF membrane system, 0.5M NaOH as stripping agent, 100 mL/min of flow rate and feed at pH 2 with 37.5% of lignosulfonate removal. The result demonstrated that the membrane support remains stable for more than 9 hours, hence demonstrating promising separation technique for lignosulfonate.

Keywords: Supported liquid membrane (SLM); lignosulfonate; extraction; trioctylamine (TOA); kerosene

© 2014 Penerbit UTM Press. All rights reserved.

1.0 INTRODUCTION

Lignosulfonate is a byproduct from sulphite pulping industry. Lignosulfonate is an anionic surfactant with dispersing, binding, complexing and emulsifying properties. This makes lignosulfonate to have a wide range of applications, such as a low cost emulsion stabilizers, concrete cure retarders and plasticizers, low cost surfactants for pesticides, oil recovery floods and drilling mud [1]. Therefore, recovery of lignosulfonate from sulphite pulp wastewater is of interest due to the economic value of lignosulfonate as well as environmental consideration. Howard process is one of the earliest and most broadly used industrial processes to recover lignosulfonate, but this process consumes lots of chemical [2]. In addition, ultrafiltration and ion-exclusion also widely used to separate lignin from sugars using ion-exchange resins [3]. However, these techniques suffer fouling problem of the membranes and high operation cost [4]. Other laboratory scale methods are dialysis, electrodialysis, precipitation in alcohol and extraction with amines [3]. These methods are not preferable in the industry due to high operation cost [1].

Recently, liquid membrane technology has emerged as a promising separation technique for various substances, especially

metal ions, to replace conventional separation methods. Liquid membranes usually utilize a thin layer of organic layers that serve a dual purpose: a barrier separating two aqueous phases (feed and strip) and as an extractant of the solute. Generally, there are three classifications for liquid membrane technology, which are bulk liquid membrane (BLM), emulsion liquid membrane (ELM) and supported liquid membrane (SLM). SLM has a simple configuration, using a hydrophobic porous membrane to hold the organic liquid membrane phase. Compared to conventional separation techniques, the use of SLMs in the separation processes offer the potential advantages such as simultaneous extraction and stripping steps, low consumption of extractant, separate high quantities of compounds using small volumes of organic phase, high selectivity, no harmful by-products are released which require additional treatment, and low capital investment and operating cost [5].

SLM technique is attractive for the extraction of polar, ionisable and even permanently charged compounds, including metal ions, which are more difficult to extract with other techniques. Canet and Seta [6] had shown the potential of using SLM to clean wastewater by the removal of soluble metal species, such as Pb^{2+} , Na^+ and Ag^+ . Another important application of SLM

is their use in gas separation processes, such as O₂/CO₂, N₂/CO₂, SO₂/CO₂N₂ etc. in the production of biogas [7]. The performance of SLM to separate lignosulfonate from aqueous solution using SLM is of interest in this study. The separation of lignosulfonate using SLM has been reported by few literatures until now. Kontturi *et al.* [8, 9] had demonstrated the possibility of using SLM with 1-decanol as solvent, triaurylamine as carrier and polytetrafluoroethylene as support to extract lignosulfonate, but the flux of lignosulfonate through this SLM was too far for practical use. On the other hand, the study done by Chakrabarty *et al.* [2] on the separation of lignosulfonate through a SLM containing trioctylamine (TOA) as carrier and dichloroethane as diluent had been reported for a separation efficiency of 90%, which is an encouraging result. However, the use of dichloroethane as diluent is doubted due to the highly volatility nature of dichloroethane. Diluent with high volatility will cause a low stability of the SLM and thus it is not encouraged to be used as membrane liquid [10].

This paper presents an experimental study on the extraction of lignosulfonate from aqueous solution through supported liquid membrane. The effects of various polymeric supports, solvents and stripping agents were tested in order to select a suitable SLM formulation for lignosulfonate extraction. The operating parameters such as feed flow rate and feed pH have significant impact on the transport of lignosulfonate through SLM and hence they were also thoroughly studied.

2.0 MATERIALS AND METHODS

2.1 Reagents and Solution

Sodium lignosulfonate salt was obtained from Sigma-Aldrich. Two types of diluents which are 1,2-dichloroethane and kerosene were purchased from Ajax Chemicals and Sigma-Aldrich respectively. The carrier used in the membrane phase, trioctylamine, C₂₄H₅₁N (TOA) was obtained from Fluka. Two types of stripping agents which are sodium hydroxide and sodium chloride were purchased from Merck KGaA. All chemicals used were in analytical grade and used as received.

The feed phase was prepared from the stock solution of 50,000 ppm lignosulfonate by dilution with water to 100ppm. The stock solution was prepared by dissolving required amount of sodium lignosulfonate salt in distilled water. Hydrochloric acid was added to the feed phase to adjust the pH of the solution. The membrane phase was prepared by dissolving 0.1M of TOA in 250mL of the selected solvent. The stripping phase was prepared by dissolving the required quantity of the stripping agent in 1 litre of distilled water to form 0.5 M solution.

2.2 SLM Preparation

The commercial membranes tested as support for the liquid membrane were Polypropylene (Accurel PP 1E) and Polyvinylidene Fluoride (Biotrace PVDF), obtained from Membrana GmbH and Pall Life Sciences respectively. Accurel PP and Biotrace PVDF have nominal pore size of 0.1µm and 0.45µm respectively. The micro-porous polymeric support was immersed in the organic liquid membrane phase for 24 hr before experiment. The pores in the polymeric support got filled with the solution by capillary action. The support was taken out of the liquid and the excess of liquid attached to the surface of the membrane was removed gently with a filter paper before it was placed in the liquid membrane cell.

2.3 Experimental Methods

The SLM extraction experiments were carried out in the liquid membrane cell as shown in Figure 1 at room temperature for 3 hours. It consists of two equal volume beakers with each containing 150mL of the feed and the strip solutions. A pump is used to recirculate the solutions through the membrane cell in counter-current flow. The flow rates of the feed phase and strip phase were set at constant rate of 100 mL/min and 50 mL/min respectively. The pH value of the feed phase was continuously monitored and adjusted at 2 by adding hydrochloric acid as and when required. 1mL of both the aqueous phases was collected in each 30 minutes interval for further analysis. The lignosulfonate content of the aqueous phases was measured using the UV-vis spectrophotometer (Jenway 7305) at 280nm. The concentrations of unknown samples were determined from the calibration curve (the value of coefficient of determination, R²=0.998) for the concentration range within 0-100ppm of lignosulfonate at 280nm wavelength [2]. The concentration of lignosulfonate extracted was calculated based on the mass balance principle.

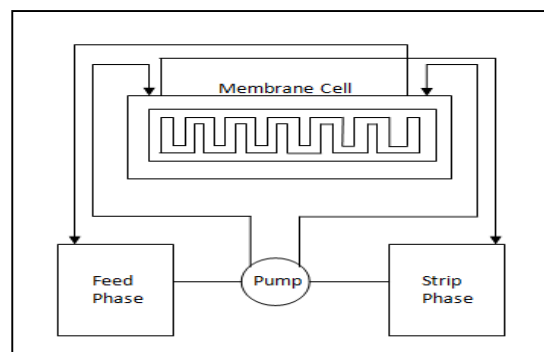

Figure 1 Liquid membrane cell for SLM study of lignosulfonate

3.0 RESULTS AND DISCUSSION

3.1 Selection of Support Material

The supports used in SLMs are generally porous to hold the organic solution or membrane liquid within its pores by capillary action. Therefore, the selection of supports has significant effect on the extraction efficiency as well as stability of SLM. The efficiency of using two different support materials, which are polyvinylidene fluoride (PVDF, 0.45µm) and polypropylene (PP, 0.1µm) in the extraction of lignosulfonate is shown in Figure 2. It can be observed that both supports show similar percentage extraction of lignosulfonate at the beginning of experiment. However, as time went on, percentage extraction in PP supported liquid membrane shows decrement, while PVDF shows continuous increment. These findings were explained by the limitation of the membrane pore size that restricts the passage of macromolecule of lignosulfonate through the membrane. When using PP membrane of 0.1µm pore size, the lignosulfonate molecules form complex on the surface of liquid membrane initially. However, since the large complex could not pass through the membrane, the complexes were accumulated on the surface. The shear force from the flow of feed phase tends to attract the complexed molecules back to the feed phase, thus increasing the concentration of feed phase, as shown by the decrease of percentage extraction in Figure 2. Therefore, Biotrace PVDF membrane was selected for subsequent experiments.

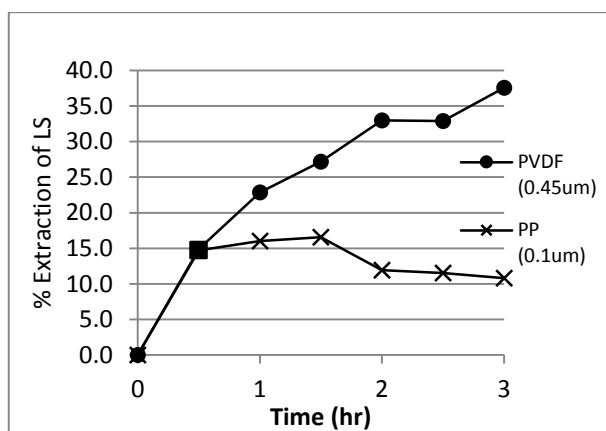

Figure 2 The extraction of lignosulfonate (LS) through SLM of different polymeric supports (membrane phase=0.1M TOA in kerosene; pH2; strip phase = 0.5M NaOH; feed flow rate=100mL/min)

3.2 Selection of Solvent

The selection of a suitable solvent for the membrane phase is a key issue for effective separation through liquid membrane system. The performance of using two different solvents, i.e. kerosene and dichloroethane with Biotrace PVDF support in the extraction of lignosulfonate were examined and the results are plotted in Figure 3. It observed that SLM extraction of lignosulfonate using kerosene as solvent with PVDF membrane as support is higher than using dichloroethane as solvent. This is probably due to the higher volatility of dichloroethane compared to kerosene. High volatility of a solvent will increase the probability of membrane liquid loss from the support, causing the SLM more unstable [10]. As a result, kerosene was chosen as the solvent for the following experiments.

In order to confirm that the extraction of lignosulfonate is based on the supported liquid membrane mechanism but not due to the flow through the pores of the membrane directly, another experiment with blank PVDF membrane (without impregnation with the organic membrane phase) was conducted. As shown in Figure 3, the extraction of lignosulfonate with blank membrane is less than 5%, confirming the SLM mechanism.

3.3 Selection of Stripping Agent

The performances of using NaOH and NaCl as stripping agents in the extraction of lignosulfonate were compared and the results are reported in Figure 4. Co-transport of lignosulfonate occurs in the liquid membrane when NaOH is used as stripping agent, while counter-transport of lignosulfonate occurs when NaCl is used. The reaction mechanisms have been proposed by Chakrabarty *et al.* [11]. Both transport modes follows the same two-step reaction mechanism at the feed-membrane interface, as shown in Equations 1 and 2, where R_3N is trioctylamine (TOA) and $LSNa_n$ is sodium lignosulfonate. However, the reaction mechanisms at the membrane-strip interface are different for two transport modes. The reactions for co-transport and counter-transport at membrane-strip interface are represented by Equations 3 and 4 respectively.

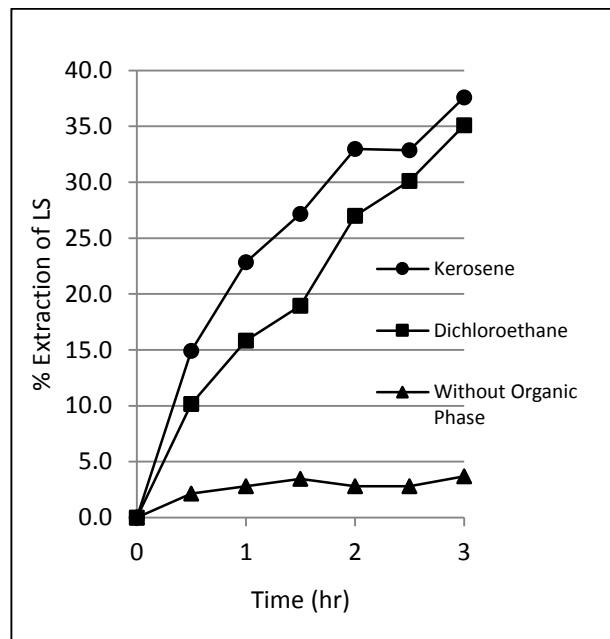
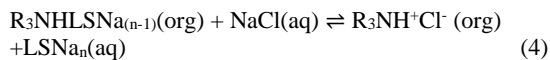
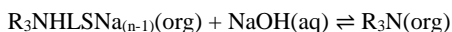
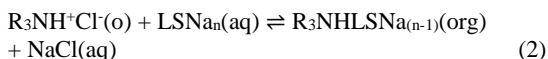

Figure 3 Effect of solvent selection on lignosulfonate (LS) extraction (support: Biotrace PVDF; pH2; strip phase = 0.5M NaOH; flow rate=100mL/min)

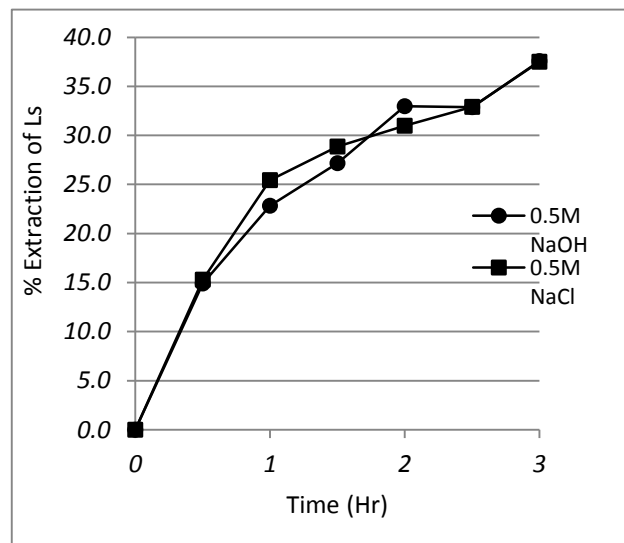

Figure 4 Comparison of lignosulfonate (LS) extraction with different stripping agents (membrane phase=0.1M TOA in kerosene; pH 2; flow rate=100 mL/min)

It can be observed from Figure 4 that both stripping agents show relative similar extraction efficiency, indicating that types of stripping agents or modes of transport do not influence the lignosulfonate extraction significantly in this study. However, this finding does not support the study conducted by Chakrabarty *et al.* [11], who used bulk liquid membrane process with dichloroethane as solvent to study the performance of the two transport modes. They have demonstrated that the performance of NaOH and Na₂CO₃ as stripping agents in co-transport mode to recover lignosulfonate is much higher than in counter-transport mode. They suggest that this result is due to the differences in the reactions at the membrane-strip interface, as indicated by reactions (3) and (4). On the other hand, the possible reason for the difference of results between the current study and the previous study [11] may due to the ineffective membrane-strip interface reaction in the current study, which is indicated by the low stripping efficiency (less than 5%) by both stripping agents. As a result, stripping reaction has insignificant effect on the extraction of lignosulfonate in this study compared to the previous study [11]. Since Chakrabarty *et al.* [2] has shown a high performance using NaOH as the stripping agent for the separation of lignosulfonate through SLM, NaOH was chosen as the stripping agent for the subsequent experiments.

3.4 Effect of Feed Flow Rate

The influence of feed flow rate on the extraction of lignosulfonate was studied in the range of 50 -150 mL/min. The results are reported in Figure 5. The results show that when the flow rate of feed phase is increased from 50 mL/min to 100 mL/min, the percentage extraction of lignosulfonate after 3 hours increases from 11.3% to 37.6%. This dependency of transport rate on the rate of flowing is explained by Altin *et al.* [12], who suggest the rate-determining step in most liquid membrane systems is the diffusion step. Before reaching the membrane phase, the solute has to diffuse through the bulk layer. The thickness of the bulk layer indicates the transition distance of the solute from the moving layer to the membrane surface. The diffusion is reversely correlated with the distance. An increase in mechanical energy supplied (higher flow rate) will decrease the thickness of diffusion film, thus reducing the resistance to solute transport. Therefore, higher solute transport and thus higher extraction percentage can be observed at higher feed flow rate.

However, when the flow rate of feed phase was further increased to 125 mL/min, the extraction of lignosulfonate after 3 hours dropped to 11.3%. This is because for an excessively thin bulk layer, the required time for the solute complexing reaction may not be sufficient [12]. Besides, higher flow rate causes higher lateral shear force, which may result in the instability of the liquid membrane. Membrane liquid attached to the surface of membrane materials is rapidly lost due to the shear force [13]. This instability effect was observed at feed flow rate of 125 mL/min by the formation of foam in the feed phase at the end of the experiment. Due to the loss of organic phase into the aqueous phase, an emulsion was formed between the organic phase and aqueous feed phase which appear as foam [11]. When the feed flow rate was further increased to 150 mL/min, the formation of foam occurs within an hour, indicating rapid degradation of the liquid membrane. Therefore, the experimental result for 150 mL/min was eliminated from the discussion. In conclusion, an efficient flow rate should be slow enough to allow for interface reactions and fast enough to minimize the resistance to the solute diffusion. In the present study, the optimum flow conditions were found to be 100 mL/min for the feed phase.

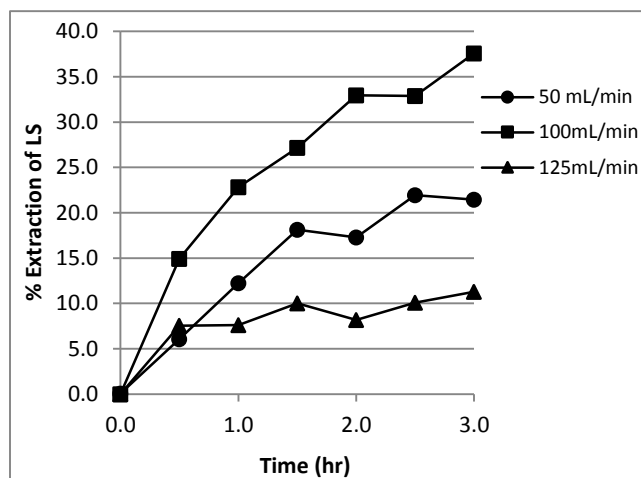

Figure 5 Effect of feed flow rate on lignosulfonate (LS) extraction (membrane phase=0.1M TOA in kerosene; pH2; strip phase = 0.5M NaOH)

3.5 Effect of Feed pH

Experiments were conducted to study the influence of the variation of pH in feed phase on the extraction of lignosulfonate. In this study, the SLM experiments were repeated at feed pH of 2, 5, original pH of the lignosulfonate solution (7.2) and 9. The experimental result shown in Figure 6 demonstrated that the extraction of lignosulfonate depends heavily on feed pH. From Figure 6, it is quite clear that the maximum extraction of lignosulfonate occurs at pH 2. This finding confirms the results of the study done by Chakrabarty *et al.* [11] which found that the optimum pH for the transport of lignosulfonate is 2. This phenomenon is reasonable since the reaction mechanism demonstrated in Section 3.3 indicates that an acidic condition is required for the protonation of TOA before complexing with lignosulfonate molecule. At pH higher than 2, the extraction of lignosulfonate decreases due to the incomplete protonation of TOA at the feed-membrane interface. Therefore, a pH equal to 2 was selected as the optimum pH for the extraction of lignosulfonate.

3.6 Stability of Supported Liquid Membrane

Stability of TOA-Kerosene-PVDF liquid membrane formulation was evaluated in terms of long time experimental runs. Performance of SLM for three consecutive runs is shown in Figure 7. The system was found to be stable for three consecutive runs, of 3 hours each without re-impregnation of the support with membrane liquid. It can be observed that the rate of extraction decreases slightly from the first run of experiment to the third run. The decreases in the extraction rate of lignosulfonate over time indicate the instability behaviour in membrane support. Since the membrane solvent in SLM is held in the pore structure solely by capillary forces, it is unavoidable that during the separation process the liquid membrane phase (carrier and/or solvent) is to some extent washed or forced out of the membrane. Van de Voorde *et al.* [14] suggested that this loss of liquid membrane phase can be due to several parameters, such as pressure difference over the membrane, solubility of carrier and membrane solvent in adjacent feed and strip solutions, wetting of support pores by the aqueous phases, blockage of support pores by precipitation of the carrier or by water or the emulsion formation of the liquid membrane phase in water induced by lateral shear forces.

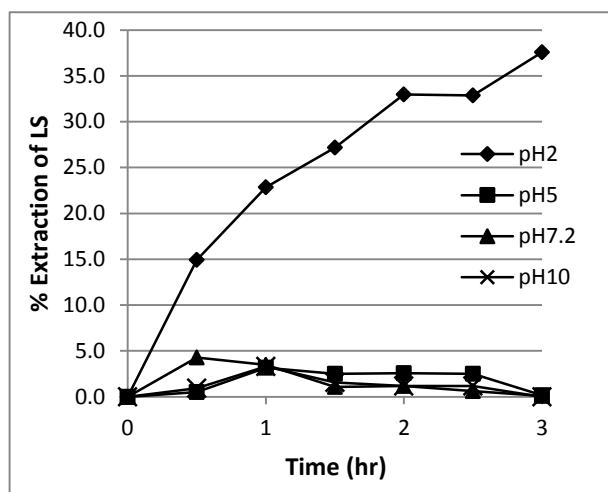

Figure 6 Effect of feed phase pH on lignosulfonate (LS) extraction (membrane phase=0.1M TOA in kerosene; feed flow rate=100 mL/min; strip phase = 0.5M NaOH)

Although the rate of extraction is decreasing, there is still continuous extraction of lignosulfonate for 9 hours, which indicates that the membrane phase is not yet completely removed from the pores and that the SLM still stable enough to block the direct diffusion between the feed and strip phases. Therefore, it can be concluded that the membrane is stable for more than 9 hours. This result may attribute to the high viscosity of the liquid membrane phase that will form a relatively stable SLM system [10]. One of the methods to enhance the SLM lifetime is the reimpregnation of the support with liquid membrane phase to keep the rate of extraction at a constant level.

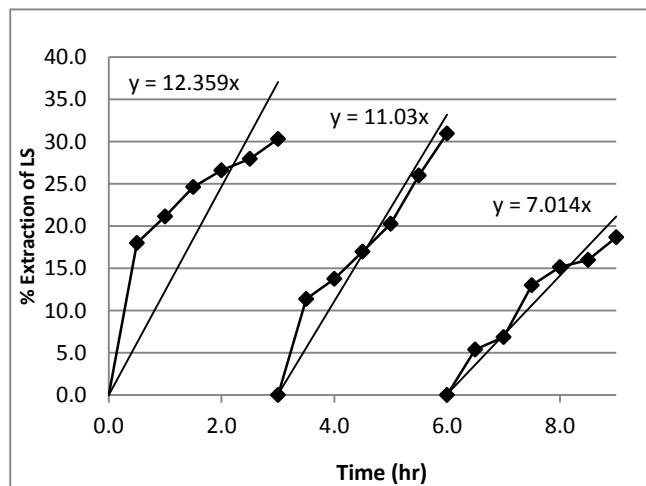

Figure 7 Performance of SLM for three consecutive runs (membrane phase=0.1M TOA in kerosene; pH 2; feed flow rate=100mL/min; strip phase = 0.5M NaOH)

4.0 CONCLUSION

The feasibility of using a SLM having Biotrace PVDF as support, trioctylamine as carrier and kerosene as solvent to extract lignosulfonate from aqueous solution has been demonstrated in this research. The effect of various process parameters on the extraction

of lignosulfonate has also been studied to optimize the process. It was found that the extraction efficiency is the best with feed flow rate at 100 mL/min. The decreasing the feed flow rate from this value will increase the resistance to the solute transport, while increasing the feed flow rate will decrease the retention time for the solute to form complex with the carrier at the feed-membrane interface. Besides, a highly acidic condition, particularly pH 2, in the feed phase is required for effective extraction of lignosulfonate through the SLM system. The proposed SLM combination of "PVDF-trioctylamine-kerosene" can achieve a percentage extraction of lignosulfonate for more than 35% at optimum condition. This SLM system can reasonably stand for continuous extraction of lignosulfonate for more than 9 hours.

Acknowledgement

The authors would like to acknowledge Ministry of Higher Education (FRGS 4F048) and Universiti Teknologi Malaysia (UTM) for providing financial assistance to this research.

References

- [1] Holladay, J.E., J.J. Bozell, J.F. White, and D. Johnson. 2007. Top Value-Added Chemicals from Biomass Volume II: Results of Screening for Potential Candidates from Biorefinery Lignin. *Technical Report*. United States: Department of Energy (DOE).
- [2] Chakrabarty, K., P. Saha, and A.K. Ghoshal. 2009. Separation of Lignosulfonate from Its Aqueous Solution Using Supported Liquid Membrane. *Journal of Membrane Science*. 340(1–2): 84–91.
- [3] Kroschwitz, J. I., and A. Seidel. 2005. *Lignin In Kirk-Othmer Encyclopedia of Chemical Technology*. 5thEd. Hoboken, N.J. Wiley-Interscience. 15: 1–25.
- [4] Liu, G., Y. Liu, J. Ni, H. Shi, and Y. Qian. 2004. Treatability of Kraft Spent Liquor by Microfiltration and Ultrafiltration. *Desalination*. 160: 131–141.
- [5] Kocherginsky, N. M., Q. Yang, and L. Seelam. 2007. Recent Advances in Supported Liquid Membrane Technology. *Separation and Purification Technology*. 53: 171–177.
- [6] Canet, L. and P. Seta. 2001. Extraction and Separation of Metal Cations in Solution by Supported Liquid Membrane Using Isalocid A as Carrier. *Pure and Applied Chemistry*. 73: 2039–2046.
- [7] Kamiński, W. and W. Kwapiński. 2000. Applicability of Liquid Membrane in Environmental Protection. *Polish Journal of Environmental Studies*. 9: 37–43.
- [8] Kontturi, A.K., K. Kontturi, P. Niinikoski, and G. Sundholm. 1990. Extraction of a Polyelectrolyte Using a Supported Liquid Membrane, I. Choice of a Suitable Carrier-Solvent System. *Acta Chemica Scandinavica* 44: 879–882.
- [9] Kontturi, A. K., K. Kontturi, P. Niinikoski, and G. Sundholm. 1990. Extraction and Fractionation of Lignosulfonate. *Acta Chemica Scandinavica*. 44: 883–891.
- [10] Dzygiel, P., and P.P. Wieczorek. 2010. Supported Liquid Membranes and Their Modifications: Definition, Classifications, Theory, Stability, Application and Perspectives. In Kislik, V. S. (Ed.). *Liquid Membranes Principles and Applications in Chemical Separations and Wastewater Treatment*. 73–140.
- [11] Chakrabarty, K., K. V. Krishna, P. Saha, and A. K. Ghoshal. 2009. Extraction and Recovery of Lignosulfonate from Its Aqueous Solution Using Bulk Liquid Membrane. *Journal of Membrane Science*. 220: 135–144.
- [12] Altin, S., S. Alemdar, A. Altin, and Y. Yildirim. 2011. Facilitated Transport of Cd(II) Through a Supported Liquid Membrane with Aliquat 336 as a Carrier. *Separation Science and Technology*. 46: 754–764.
- [13] Zheng, H. D., B.Y. Wang, Y.X. Wu, and Q. L. Ren. 2009. Instability Mechanisms of Supported Liquid Membranes for Copper (II) Ion Extraction. *Colloid and Surfaces A*. 351: 38–45.
- [14] Van de Voorde, L., L. Pinoy, and R.F. De Ketelaere. 2004. Recovery of nickel Ions by Supporting liquid Membrane (SLM) Extraction. *Journal of Membrane Science*. 234: 11–21.