

A Comparative Study of Linear ARX and Nonlinear ANFIS Modeling of an Electro-Hydraulic Actuator System

T. G. Ling, M. F. Rahmat*, A. R. Husain

Department of Control and Mechatronic Engineering, Faculty of Electrical Engineering, Universiti Teknologi Malaysia, 81310 UTM Johor Bahru, Johor, Malaysia

*Corresponding author: fuaad@fke.utm.my

Article history

Received :5 August 2013
Received in revised form :
28 November 2013
Accepted :15 January 2014

Graphical abstract

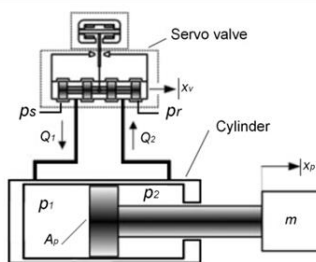

Abstract

The existence of a high degree of nonlinearity in Electro-Hydraulic Actuator (EHA) has imposed a challenge in development of a representable model for the system such as that significant control performance can be proposed. In this work, linear Autoregressive with Exogenous (ARX) model and nonlinear Adaptive Neuro-Fuzzy Inference System (ANFIS) model of an EHA system are obtained based on the mathematical model of the system. Linear ARX modeling technique has been widely applied on EHA system and satisfying result has been obtained. On the other hand, ANFIS modeling technique can model nonlinear system at high accuracy. Both models are validated offline using data set obtained and using different stimulus signals when doing online validation. Offline validation test shows that ANFIS model has 99.37% best fitting accuracy, which is more accurate than 93.75% in ARX model. ARX model fails in some online validation tests, while ANFIS model has been consistently accurate in all tests with RMSE lower than 0.25.

Keywords: ARX; ANFIS; EHA; mathematical model; model validation

Abstrak

Kewujudan darjah tak-linear yang tinggi dalam Electro-Hydraulic Actuator (EHA) telah mengenakan kerja yang mencabar dalam membangunkan model yang mampu mewakili sistem supaya prestasi kawalan yang ketara boleh dicadangkan. Dalam karya ini, model linear Autoregressive with Exogenous (ARX) dan model tak-linear Adaptive Neuro-Fuzzy Inference System (ANFIS) untuk satu sistem EHA diperolehi berdasarkan model matematik sistem. Teknik model linear ARX telah digunakan secara meluas pada sistem EHA dan hasil yang memuaskan telah diperolehi. Sebaliknya, teknik model ANFIS boleh model sistem tak-linear pada ketepatan yang tinggi. Kedua-dua model adalah disahkan di luar talian dengan menggunakan set data yang diperolehi dan menggunakan isyarat rangsangan yang berbeza apabila melakukan pengesahan dalam talian. Ujian pengesahan luar talian menunjukkan bahawa model ANFIS mempunyai 99.37% ketepatan terbaik sesuai, yang lebih tepat berbanding 93.75% pada model ARX. Model ARX gagal dalam beberapa ujian pengesahan dalam talian, manakala model ANFIS telah secara konsisten, tepat dalam semua ujian dengan RMSE lebih rendah daripada 0.25.

Kata kunci: ARX; ANFIS; EHA; model matematik; pengesahan model

© 2014 Penerbit UTM Press. All rights reserved.

1.0 INTRODUCTION

Electro-Hydraulic Actuator (EHA) system is one of the fundamental drive systems in industrial sector and engineering practice. EHA system has more advantage over electric drives in certain applications because of its high power density, fast and smooth response, high stiffness and good positioning capability [1]. Examples of applications of EHA systems are electro-hydraulic positioning systems [2, 3], active suspension control [4], and industrial hydraulic machines [5]. EHA system's ability to generate high forces in conjunction with fast response time

and have good durability, puts the system in high interest among heavy engineering applications [6].

Due to the merit in high power density and positioning under high force application, EHA system's position tracking accuracy has been one of the most interesting research areas in last decades. The nonlinearities, uncertainties [7] and time varying characteristics [8] of the system have made the research challenging for precise and accurate control [9]. In order to design a good and precise controller for the system, system model which can accurately represent the real system has to be obtained first.

The process to obtain the model is the first step of system analysis [10]. Modeling can be done either by physical law based modeling or system identification. Physical law based modeling method such as performed in [1, 11-15] is hard to perform as it requires expert knowledge and thorough understanding of the system, and model's parameters are hard to identify. System identification requires only set of stimulus-response data and no prior knowledge of the system in order to construct the model and obtain the parameter.

There are a number of researches which apply system identification technique to construct a linear model for EHA system. A linear model is popular as it is the simplest, discrete time model which can represent the relationship between input and output. Among the linear model used, Autoregressive with exogenous (ARX) model is widely used to represent EHA system [16-21]. Those researches have shown that ARX model can approximate the EHA system with high precision. However, as the model structure is not known, the ARX model structure is determined by trying different system order to obtain a model with best accuracy and lowest system order based on the Parsimony Principle [22, 23]. The method requires multiple tests on different orders of ARX model for accurate model. In this paper, ARX model's order for EHA system is determined from mathematical modeling of the system, which eliminates the need of different tests.

Fuzzy modeling technique is another alternative to construct a model for the system under test. Adaptive Neuro-Fuzzy Inference System (ANFIS) [24] which is the major training routine of Takagi-Sugeno fuzzy model, has shown the excellent ability to estimate nonlinear systems for different applications [25-29]. However, despite the ability of the technique in modeling, it is not widely used on modeling an EHA system. Fuzzy modeling technique which has been applied in [30, 31] uses a Mamdani model to represent an EHA system, and the result is satisfactory. The technique used for the research is heuristic in determining the number of membership functions of the model while the data set from the system is used in generating rules of the model. The research can be improved by applying ANFIS method in modeling technique, where the number of membership functions can be reduced while concurrently, maintain the high precision in estimation. An accurate fuzzy model for EHA system has been obtained using ANFIS approach [21]. The number and the variable of the inputs to the model are selected by the trial-and-error method, depending on a set of single input single output stimulus-response data set. This heuristic search returns in input variables which consist of different sample delays of the stimulus and response variables, and occasionally, the search fails by choosing only response variables as model's input. Thus, alternative approach of model's input variable selection is developed by referring to simplified mathematical model of the EHA system. This new approach will provide a clear visual on which inputs are relevant for the system, and corresponding data set can be obtained for parameter identification purpose.

The objective of this paper is to obtain a linear ARX model and a nonlinear ANFIS model based on EHA system's mathematical modeling. Both ARX and ANFIS models are obtained and trained using the same set of stimulus response data set. The models are later validated using offline data sets and using different stimulus signals when performing online model validation.

2.0 MATHEMATICAL MODELING OF EHA SYSTEM

Main parts of an EHA system under test consist of servo valve, hydraulic cylinder and load attached to the single ended piston as shown in Figure 1. In the figure, p_s and p_r represent hydraulic supply and return pressure, x_v and x_p represent spool valve displacement and piston displacements. Q_1 and Q_2 are the fluid flow from and to cylinder while p_1 and p_2 are the fluid pressure in upper and lower cylinder chambers.

There are some basic assumptions [24] to be taken into considerations for modeling purpose; 1, the friction loss and influence from the mass of fluid in conduits can be neglected, 2, pressure in one chamber is same everywhere, 3, temperature and bulk modules of elasticity are assumed to be constants, and 4, the supply pressure is a constant and return pressure is zero.

The dynamic of the piston motion can be derived as

$$\begin{aligned}\dot{x}_p &= v_p \\ \dot{v}_p &= a_p\end{aligned}\quad (1)$$

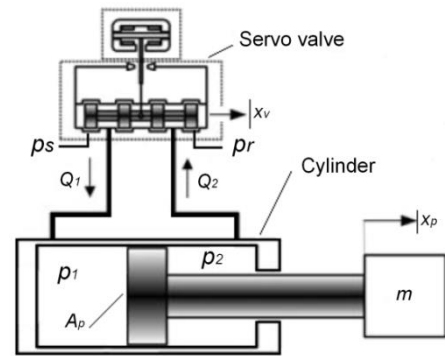

Figure 1 Electro-hydraulic actuator system

Based on Newton's second law of motion,

$$ma_p = F_a - F_f - f_d \quad (2)$$

where the variables are:

\dot{x}_p and v_p	piston velocities
\dot{v}_p and a_p	piston accelerations
m	total mass of the piston and load
F_a	hydraulic actuating force
F_f	hydraulic friction force
f_d	lumped uncertain nonlinearities due to external disturbance and other hard to model linear term

As shown in assumption 1, the hydraulic friction force is neglected, which is assumed to be term that is hard to model and parameters are hard to obtain. Thus, Equation (2) is reduced to

$$ma_p = F_a - f_d \quad (3)$$

Hydraulic actuating force, F_a is represented as

$$F_a = A_1 p_1 - A_2 p_2 \quad (4)$$

Thus,

$$ma_p = (A_1 p_1 - A_2 p_2) - f_d \quad (5)$$

where A_1 and A_2 are the cross section area of chambers of the cylinder.

Defining the load pressure to be the pressure across the actuator piston, the derivative of the load pressure P_L , is given by total load flow through the actuator cylinder divided by fluid capacitance [25]:

$$\begin{aligned} \frac{V_1}{\beta_e} \dot{p}_1 &= -A_1 v_p - C_t P_L + Q_1 \\ \frac{V_2}{\beta_e} \dot{p}_2 &= A_2 v_p + C_t P_L - Q_2 \end{aligned} \quad (6)$$

where,

$V_1 = V_{i1} + A_1 x_p$, $V_2 = V_{i2} + A_2 x_p$, $P_L = P_1 - P_2$	
V_1 and V_2	total volume of first and second chambers
V_{i1} and V_{i2}	initial volume of both chambers including pipelines volume
β_e	effective bulk modulus of hydraulic oil
C_t	coefficient of internal leakage of the chamber
Q_1 and Q_2	supply and return flow rates of forward and return chambers

Valve displacement and the flow rate are governed by the orifice law [25, 26]. Neglecting the leakage in valve, then

$$\begin{aligned} Q_1 &= C_{v1} \sqrt{\Delta p_1}, \Delta p_1 = \begin{cases} p_s - p_1 & \text{for } x_v \geq 0 \\ p_1 & \text{for } x_v < 0 \end{cases} \\ Q_2 &= C_{v2} \sqrt{\Delta p_2}, \Delta p_2 = \begin{cases} p_2 & \text{for } x_v \geq 0 \\ p_s - p_2 & \text{for } x_v < 0 \end{cases} \end{aligned} \quad (7)$$

where,

$$C_{v1} = C_d w_1 x_v \sqrt{\frac{2}{\rho}}, \text{ and } C_{v2} = C_d w_2 x_v \sqrt{\frac{2}{\rho}} \quad (8)$$

C_{v1} and C_{v2}	valve orifice coefficients
C_d	discharge coefficient
p_s	supply pressure
w_1 and w_2	spool valve area gradients
ρ	oil density

Dynamic of servo valve is given by [27],

$$\dot{x}_v = \frac{1}{\tau_v} (-x_v + k_a u) \quad (9)$$

where,

k_a	servo valve gain
τ_v	time constant

The effects of servo valve dynamics are neglected as it requires an additional sensor to obtain the spool position and only minimal performance improvement is achieved for position tracking [28]. Thus, the spool valve displacement is simplified as

$$x_v = k_a u \quad (10)$$

With the state variable, $x = [x_1, x_2, x_3]^T \equiv [x_p, v_p, a_p]^T$, from equation (1) to (10), the state model of EHA system is obtained by replacing servo valve dynamic (9) by (10), which is

$$\begin{aligned} \dot{x}_1 &= x_2 \\ \dot{x}_2 &= x_3 \end{aligned}$$

$$\dot{x}_3 = \dot{a}_p = \frac{1}{m} [(A_1 \dot{p}_1 - A_2 \dot{p}_2) - \dot{f}_d] \quad (11)$$

Substituting $P_L = P_1 - P_2$ into (5), and (6), (7), (8), (10) into (11), then

$$\dot{x}_3 = ax_2 + bx_3 + cu + d \quad (12)$$

where,

$$\begin{aligned} a &= -\frac{\beta_e}{m} \left(\frac{A_1^2}{V_1} + \frac{A_2^2}{V_2} \right) \\ b &= -\frac{\beta_e C_t}{A_1} \left(\frac{A_1}{V_1} + \frac{A_2}{V_2} \right) \\ c &= \frac{\beta_e C_d k_a \sqrt{2/\rho}}{m} \left(\frac{A_1 w_1}{V_1} \sqrt{\Delta p_1} + \frac{A_2 w_2}{V_2} \sqrt{\Delta p_2} \right) \\ d &= \frac{\beta_e C_t}{m} \left(\frac{A_1}{V_1} + \frac{A_2}{V_2} \right) \left(\frac{A_1 + A_2}{A_1} \right) p_2 - \frac{\dot{f}_d}{m} \end{aligned}$$

As x_p is the position output of EHA system, we denote x_p as y . Rewriting equation (12) and neglecting term \dot{f}_d which is lumped uncertain nonlinearities and other hard to model linear terms, we obtain

$$\ddot{y} = ay + b\dot{y} + cu \quad (13)$$

where \ddot{y} is the change of acceleration per second, jerk. Taking Laplace transform of equation (13),

$$\frac{Y(s)}{U(s)} = \frac{c}{s^2 - bs - a}. \quad (14)$$

Equation (14) has shown that the EHA system is a third order system. Rewrite equation (14), obtain

$$Y(s) = \frac{\frac{\beta_e C_d k_a \sqrt{2/\rho}}{m} \left(\frac{A_1 w_1}{V_1} \sqrt{\Delta p_1} + \frac{A_2 w_2}{V_2} \sqrt{\Delta p_2} \right)}{s^2 + \frac{\beta_e C_t}{A_1} \left(\frac{A_1}{V_1} + \frac{A_2}{V_2} \right) s + \frac{\beta_e}{m} \left(\frac{A_1^2}{V_1} + \frac{A_2^2}{V_2} \right)} U(s) \quad (15)$$

Corresponding discrete time model is obtained by performing zero order hold transformation of continuous time model of equation (15). The structure of discrete time model is as follow

$$G(q^{-1}) = \frac{y(q)}{u(q)} = \frac{b_1 q^{-1} + b_2 q^{-2} + b_3 q^{-3}}{1 + a_1 q^{-1} + a_2 q^{-2} + a_3 q^{-3}} \quad (16)$$

Let $Y(s) = y$, $U(s) = u$, the electro-hydraulic actuator system as in Figure 1 can be represented in a simplified functional relation given by

$$y = f(u, p_1, p_2, V_1, V_2) \quad (17)$$

As V_1 and V_2 is directly proportional to x_p , the functional relation (17) is further simplify to

$$y = f(u, p_1, p_2, y) \quad (18)$$

From Equation (18), it is shown that in order to obtain the position of the piston, x_p , it requires the input signal u , pressure p_1 and p_2 , and piston position x_p . As it is impossible to obtain the signal at the time to calculate the new piston position, the signal of p_1 , p_2 , and x_p are taken to be a previous one sample value. Thus, equation (18) are written as

$$y(k) = f(u(k), p_1(k-1), p_2(k-1), y(k-1)) \quad (19)$$

3.0 MODELING PROCESS

Identification of both linear ARX model and nonlinear ANFIS model is performed on MATLAB platform. To perform system identification on the EHA system, a set of stimulus-response signals has to be obtained. Stimulus signal is used to excite the system and produce response signal. When the stimulus signal can excite more operating region of the system, stimulus-response data set obtained will contain more system characteristics. The variation of stimulus signal is able to excite different operating region within the system, thus characteristics of the system will be expressed in the system response data obtained [13, 17, 20]. Stimulus signal that used to excite the EHA system is a multisine signal which consists of different amplitudes and frequencies, given by (20).

$$y = 1.5\cos2\pi0.05t + 1.5\cos2\pi0.2t + 2.5\cos2\pi t \quad (20)$$

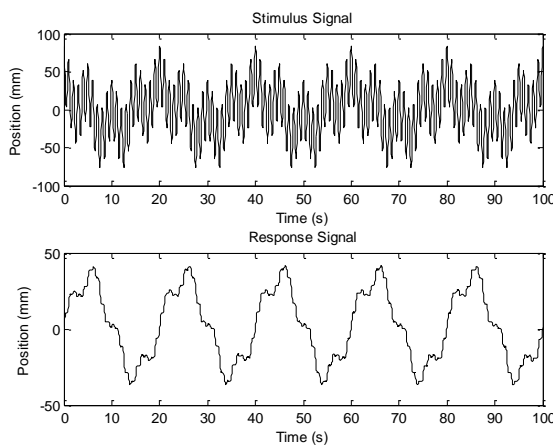

Figure 2 Stimulus response signal

Equation (20) shows that the stimulus signal comprises of three different frequencies, which are 0.05Hz, 0.2Hz and 1Hz. The highest frequency of stimulus signal is limited to 1Hz, as the EHA system performs like a low-pass filter, which only response at low frequencies. Figure 2 shows the stimulus and the response signal of EHA system.

ANFIS modeling is the integration of the interpretability of a fuzzy inference system with adaptability of a neural network [29]. ANFIS architecture as shown in Figure 3 contains five layers in the inference system. Each layer involves several nodes, which is described by node functions. Nodes are having similar function among layers and different function between layers. Output of the nodes of present layers will be served as input for the next layers. Details of the nodes' function can be found in [29].

In this paper, an ARX model and an ANFIS model is obtained from data set of EHA system which is excited using signal (20) and later the accuracy of both models is compared. Figure 4 shows the general ARX model, where u and y represent input and output, e indicates the error signal, A and B are parameters to be estimated. Takagi-Sugeno fuzzy model is chosen as ANFIS model. General form of Takagi-Sugeno fuzzy model is shown in Figure 5. Three fuzzy inputs and one functional output are determined. Each input contains two generalized bell (gbell) membership functions. Functional output of Takagi-Sugeno model is a linear model.

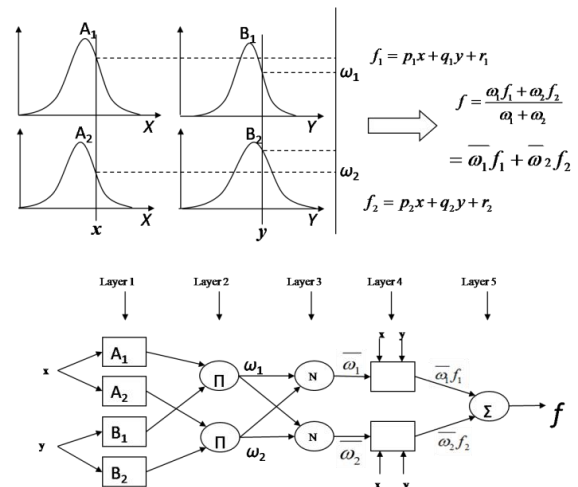

Figure 3 ANFIS architecture

Parameters in ARX model are obtained using the least-squared method as the method is straight forward and fast in estimating the parameters. ARX model with the calculated parameters fit the system with least error. ANFIS constructs the model by performing grid partitioning on data set and the parameters are estimated by the hybrid learning algorithm. Consequent parameters of ANFIS are estimated by the least squared method in forward pass while premise parameters are estimated by gradient descent method in backward pass. When the models are obtained, validation of the models is done on the check data set, which will be discussed later. Accuracy of the models is compared. In this paper, RMSE (Root Mean Squared Error) and Best Fitting Percentage are used as standard to indicate the precision of either ARX or ANFIS model.

The data set is captured at sampling time 50ms, which is the best sampling interval through observation [20]. The data recorded for 100 seconds, which equivalent to 2000 sample data. Modeling is performed by firstly divide the sample data into train data and check data. Train data is used to train the parameters of the model, while check data is used to validate the model. ARX model structure is determined based on physical modeling of EHA system shown by equation (15). Thus, the ARX discrete model is third order with the structure of equation (16). ANFIS model structure is described as in Figure 3. Input variable of the model is selected based on equation (19). Thus, there are four inputs to the nonlinear ANFIS model.

In this paper, both linear ARX model and nonlinear ANFIS model are obtained using the same set of train data. The models obtained are validated using check data set. Accuracy of both model is later compared in terms of best fitting percentage and RMSE (Root Mean Squared Error). Apart from model validation using offline data, both models are also validated online using different stimulus signal to verify the accuracy of the models.

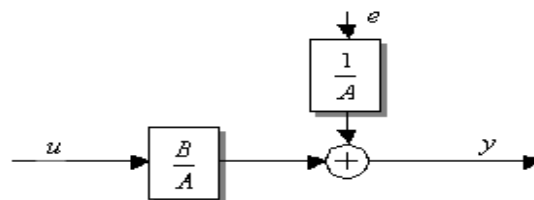

Figure 4 General linear ARX model

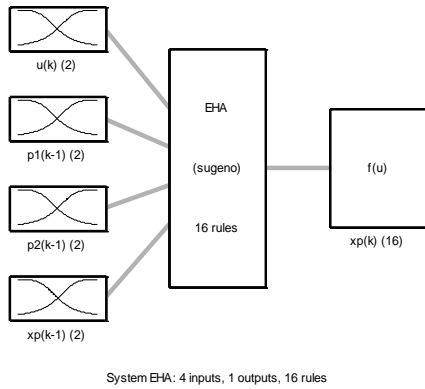

Figure 5 Takagi-Sugeno fuzzy model

4.0 RESULTS AND DISCUSSIONS

Linear ARX model and nonlinear ANFIS model are obtained by set of stimulus response data from EHA system. The data set is divided into two parts. First part of the data set is used in the model identification process while another part is used to validate the model. The accuracy of the model is measured in best fitting percentage and Root Mean Squared Error (RMSE) between simulated response and real response of the system. Best fitting percentage and RMSE formula is given as equation (21) and (22).

$$fit = 100 \frac{(1 - \text{norm}(\text{simulated response} - \text{real response}))}{\text{norm}(\text{simulated response} - \text{mean}(\text{real response}))} \quad (21)$$

$$RMSE = \frac{\text{norm}(\text{simulated response} - \text{real response})}{\sqrt{\text{number of data}}} \quad (22)$$

where, $\text{norm}(x)$ is the Euclidean length of vector x .

4.1 Model Identification and Validation

The model identification of both ARX and ANFIS model is done in MATLAB platform. Linear ARX model with third order structure based on mathematical modeling of EHA system is obtained as in Figure 4. Neglecting the term e , the model is expressed as,

$$A(q)y(t) = B(q)u(t) \quad (23)$$

where,

$$A(q) = 1 - 1.781q^{-1} + 0.9148q^{-2} - 0.1333q^{-3} \quad (24)$$

$$B(q) = 0.02439q^{-1} - 0.0276q^{-2} + 0.01095q^{-3} \quad (25)$$

The model validation of the model against the actual response is shown in Figure 6,

Result in Figure 6 shows that the model obtains high accuracy at 93.75% with 1.42 RMSE. This result displayed the high accuracy of the model, however, when zoom into the figure, it shows that the model is failed to estimate the system response at the change of response direction, as shown in smaller figure in Figure 6. Later in this paper will show the effect of above issue to the performance estimation of the real system. Error plot in Figure 6 also shows the ARX model's estimation has error ranging from about -2 mm to 4 mm.

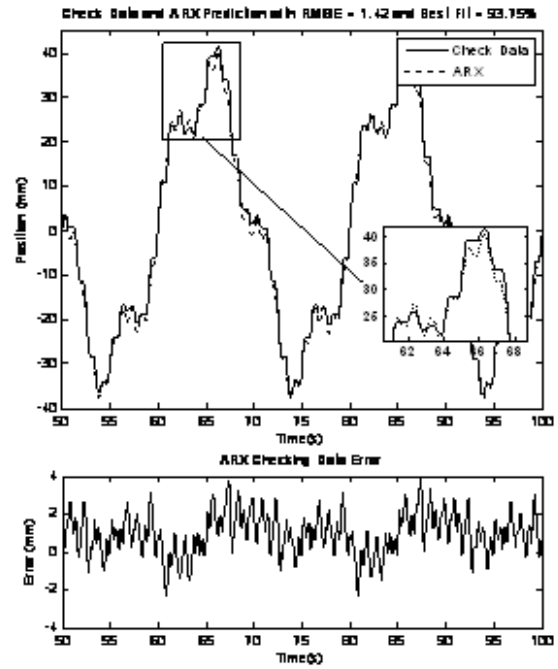

Figure 6 Model validation of linear ARX model.

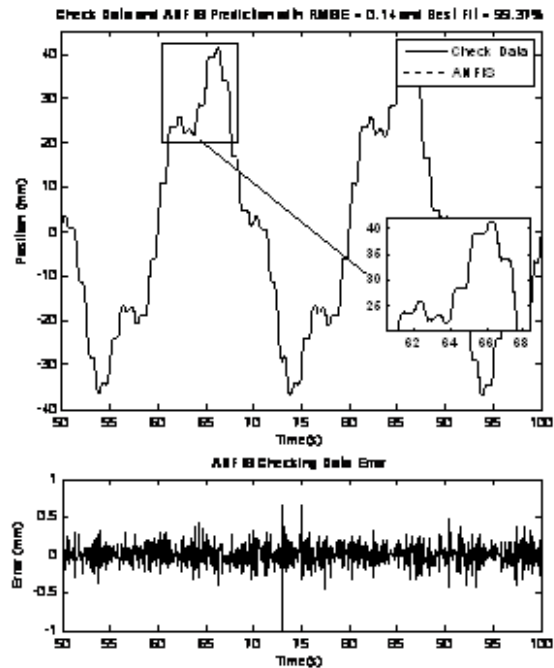

Figure 7 Model validation of nonlinear ANFIS model

ANFIS model, having four inputs, $u(k)$, $y(k-1)$, $p_1(k-1)$, and $p_2(k-2)$, output $y(k)$, with $u(k)$ and $y(k)$ indicate the stimulus and response signals, $y(k-1)$, $p_1(k-1)$, and $p_2(k-1)$ are the delay sample of response signal, pressure 1 and 2 corresponding. Input selection of the model is based on simplified mathematical modeling equation (19). Structure of the model and inputs of the ANFIS is shown in Figure 5. Each input variable has two membership functions and the model contains 16 rules, with a linear output for each rule. The final output is the average of total linear outputs. The ability of ANFIS to model nonlinear

system shall be able to model the EHA system in high accuracy. Figure 7 shows the result of ANFIS model validation.

ANFIS model simulation plot in Figure 7 shows the best fitting percentage of 99.37% and RMSE of 0.14. This shows that the model is very accurate and almost estimate every EHA response accurately. The ANFIS model is able to estimate the system response even when the response change direction, as shown in smaller figure in Figure 7. The high accuracy of ANFIS model also shown in error plot with error ranging less than $\pm 0.5\text{mm}$.

The result of model validation of both models clearly shows the superior of ANFIS model over ARX model. ARX model having the lower best fitting accuracy and higher RMSE while ANFIS model having significantly better accuracy and lower RMSE. ARX model prediction having large error portion, while ANFIS model prediction has much lower error. Zoom in figure of both model response show that ANFIS model is more capable to estimate EHA's response, especially during the change of response direction. Eventhough ARX model has lower best fitting accuracy and larger error, the model is still acceptable due to its simplicity. In next section, both the models are validated online to check the feasibility of the models in different situation

4.2 Online Close Loop Model Validation

Online model validation is done in MATLAB simulink platform as shown in Figure 8. Same stimulus signal is supplied to ARX model and ANFIS model which was identified early on, as well as the real EHA plant. For ANFIS model, there are two additional sensors which measure the pressure of chamber 1 and chamber 2. The response of the models and EHA system are collected and compared.

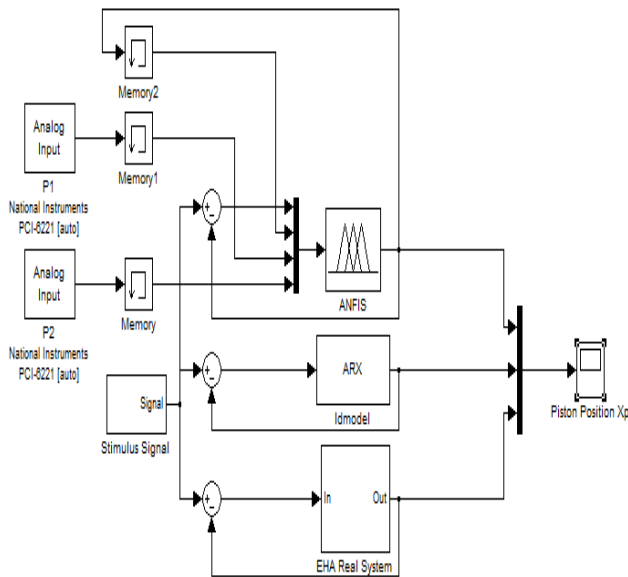

Figure 8 Simulink diagram of online model validation

During online close loop model validation, no controller is included in the system. Stimulus signal used is identical with the signal in the model identification process. This validation test is conducted to investigate the ability of the models to predict system performance in close loop condition. The validation

result as shown in Figure 9, ARX model performs better than in open loop condition, with lower RMSE, 0.86. This situation appears as during close loop system, some nonlinearities which exist in system as in open loop condition is eliminated, and the close loop configuration act as a controller to the system. Thus, ARX model can estimate the system with higher precision. Error plot of ARX model estimation also lower than in the identification step. Based on observation on Figure 10, ANFIS model shows a more significant performance in term of accuracy for the model estimation with RMSE = 0.17, with low error ranging in $\pm 0.5\text{mm}$.

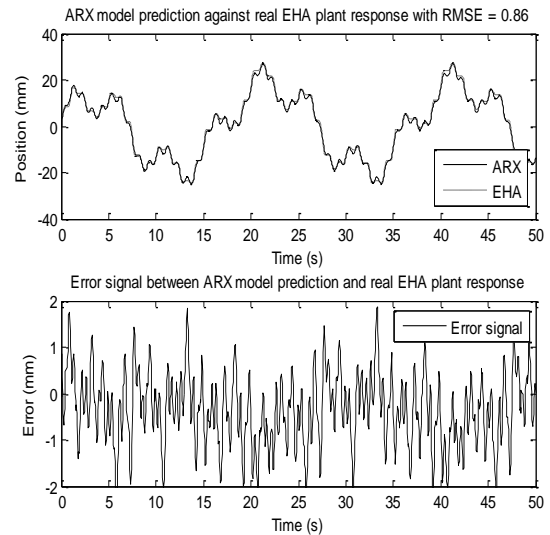

Figure 9 ARX model online validation in close loop

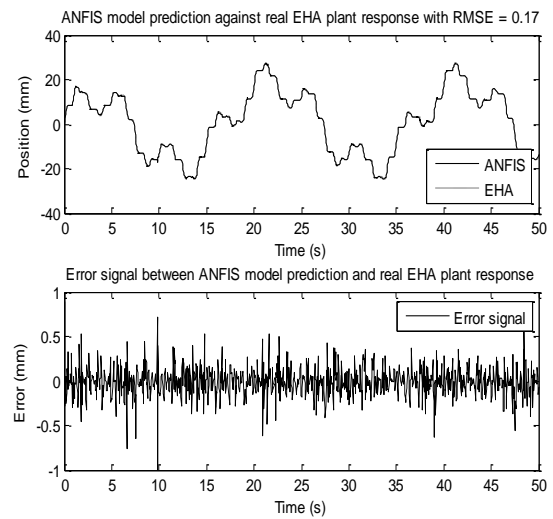

Figure 10 ANFIS model online validation in close loop

In next section, EHA system in close loop condition, is excited with different types of signal other than stimulus signal as in the system identification process. The purpose of these testing is to examine the ability of both models to predict the response when given inputs where the model is not trained with.

4.3 Other Online Model Validation

In this section, EHA system is excited using different signals, which is sine wave, and square wave. All the input reference signals are not shown in figures, as this validation test is not for the control purpose. The estimation of the models and real EHA response is compared. Model validation test of models with sine wave and square wave is shown in Figure 11 and Figure 12.

From the results shown in both Figure 11 and 12, ANFIS model has outperformed ARX model in every online test. ARX model estimation has a big error compare to the actual response of EHA system. The ARX model, even though having a high percentage of accuracy during system identification process, it fails to estimate the response of EHA when using stimulus signal that is not trained with. Suitable explanation of the phenomena is that the ARX model is failed to model the nonlinearity and uncertainties which exist within the EHA system. Zoomed in plot in Figure 6 and Figure 7 explains the above statement. ANFIS model which can model the nonlinear characteristic of the system can predict the performance of the real EHA plant. From most of the model validation test, ANFIS model's prediction result in very low error, which are indicated by low RMSE and high best fitting percentage.

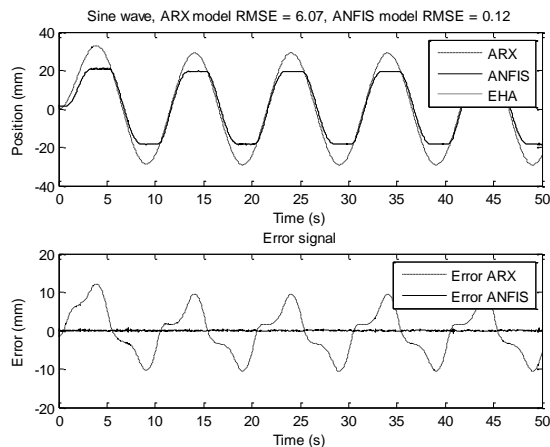

Figure 11 ARX and ANFIS model validation using sine wave

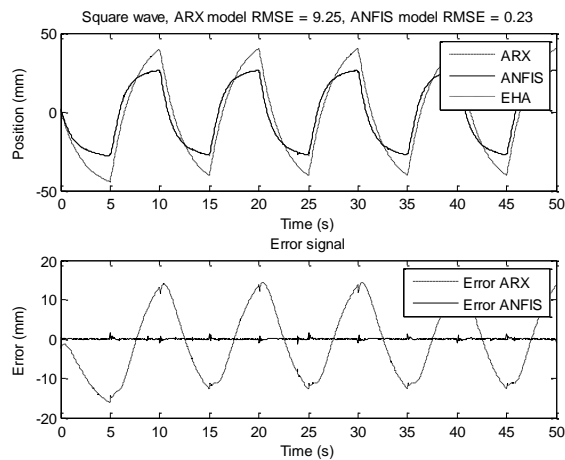

Figure 12 ARX and ANFIS model validation using square wave

5.0 CONCLUSION

A linear ARX and a nonlinear ANFIS model are obtained using system identification method based on mathematical modeling of EHA system. Mathematical modeling of the system provides useful information for system identification process, such as the system order for ARX model and relevant input variables for ANFIS model. Both models identified from stimulus-response data set provides model's parameters which are hard to be obtained through physical modeling. Based on the model verification through several different validation conditions, it is concluded that ANFIS model is a more accurate model than ARX model. ANFIS model has performed better with significantly higher accuracy than ARX model because of its nonlinear approximation capability. Model validation test also has shown that ANFIS model can predict the EHA response even though the system is operating in nonlinear condition, or being excited with different stimulus signal. The accurate ANFIS model can be used for the purpose of designing suitable model based controller in the further study.

Acknowledgement

This research is supported by the Ministry of Higher Education of Malaysia under MyBrain 15 program and Universiti Teknologi Malaysia (UTM) through Research University Grant (GUP) Tier 1 vote number Q.J130000.2523.02H73. Authors are grateful to the Ministry and UTM for supporting the present work.

References

- [1] A. Alleyne and R. Liu. 2000. A Simplified Approach to Force Control for Electro-Hydraulic Systems. *Control Engineering Practice*. 8: 1347–1356.
- [2] P. M. FitzSimons and J. J. Palazzolo. 1996. Part I: Modeling of a One-Degree-of-Freedom Active Hydraulic Mount. *ASME J. Dynam. Syst., Meas., Contr.* 118: 439–442.
- [3] P. M. FitzSimons and J. J. Palazzolo. 1996. Part II: Control of a One-Degree-of-Freedom Active Hydraulic Mount. *ASME J. Dynam. Syst., Meas., Contr.* 118: 443–448.
- [4] A. Alleyne and J. K. Hendrick. 1995. Nonlinear Adaptive Control of Active Suspensions. *IEEE Trans. Contr. Syst. Technol.* 3: 94–101.
- [5] B. Yao, J. Zhang, D. Koehler, and J. Litherland. 1998. High Performance Swing Velocity Tracking Control of Hydraulic Excavators. In Proc. American Control Conf. 818–822.
- [6] H. E. Merrit. *Hydraulic Control Systems*. New York: John Wiley & Sons, Inc.
- [7] K. Ahn and J. Hyun. 2005. Optimization of Double Loop Control Parameters for a Variable Displacement Hydraulic Motor by Genetic Algorithms. *JSME International Journal Series C-Mechanical Systems Machine Elements and Manufacturing*. 48: 81–86.
- [8] S. Y. Lee and H. S. Cho. 2003. A Fuzzy Controller for an Electro-Hydraulic Fin Actuator Using Phase Plane Method. *Control Engineering Practice*. 11: 697–708.
- [9] A. G. Loukianov, E. Sanchez, and C. Lizalde. 2008. Force Tracking Neural Block Control for an Electro-Hydraulic Actuator Via Second-Order Sliding Mode. *International Journal of Robust and Nonlinear Control*. 18: 319–332.
- [10] G. H. Shakouri and H. R. Radmanesh. 2009. Identification of a Continuous Time Nonlinear State Space Model for the External Power System Dynamic Equivalent by Neural Network. *Electrical Power and Energy Systems*. 31: 334–344.
- [11] T. Sugiyama and K. Uchida. 2004. Gain-scheduled Velocity and Force Controllers for Electrohydraulic Servo System. *Electrical Engineering in Japan*. 146: 65–73.
- [12] H. C. Lu and W. C. Lin. 1993. Robust Controller with Disturbance Rejection for Hydraulic Servo Systems. *IEEE Transactions on Industrial Electronics*. 40: 157–162.

- [13] M. F. Rahmat, S. M. Rozali, N. A. Wahab, and Zulfatman. 2010. Application of Draw Wire Sensor in Position Tracking of Electro Hydraulic Actuator System. *International Journal on Smart Sensing and Intelligent Systems*. 3: 736–755.
- [14] R. Ghazali, Y. M. Sam, M. F. Rahmat, A. W. I. M. Hashim, and Zulfatman. 2010. Sliding Mode Control with PID Sliding Surface of an Electro-hydraulic Servo System for Position Tracking Control. *Australian Journal of Basic and Applied Sciences*. 4: 4749–4759.
- [15] M. F. Rahmat, Zulfatman, A. R. Husain, K. Ishaque, and M. Irhouma. 2010. Self-Tuning Position Tracking Control of an Electro-Hydraulic Servo System in the Presence of Internal Leakage and Friction. *International Review of Automatic Control*. 3: 673–683.
- [16] R. Ghazali, Y. M. Sam, M. F. Rahmat, and Zulfatman. 2009. On-line Identification of an Electro-hydraulic System using Recursive Least Square. In IEEE Student Conference on Research and Development (SCOReD 2009). 471–474.
- [17] M. F. Rahmat, S. M. Rozali, N. A. Wahab, Zulfatman, and K. Jusoff. 2010. Modeling and Controller Design of an Electro-Hydraulic Actuator System. *American Journal of Applied Sciences*. 7: 1100–1108.
- [18] R. Ghazali, Y. M. Sam, M. F. Rahmat, K. Jusoff, Zulfatman, and A. W. I. M. Hashim. 2011. Self-Tuning Control of an Electro-Hydraulic Actuator System. *International Journal on Smart Sensing and Intelligent Systems*. 4: 189–204.
- [19] Zulfatman and M. F. Rahmat. 2009. Application of Self-tuning Fuzzy PID Controller on Industrial Hydraulic Actuator Using System Identification Approach. *International Journal on Smart Sensing and Intelligent Systems*. 2: 246–261.
- [20] T. G. Ling, M. F. Rahmat, A. R. Husain, and R. Ghazali. 2011. System Identification of Electro-Hydraulic Actuator Servo System. In 4th International Conference On Mechatronics (ICOM). Kuala Lumpur, Malaysia. 1–7.
- [21] M. F. Rahmat, T. G. Ling, A. R. Husain, and K. Jusoff. 2011. Accuracy Comparison of ARX and ANFIS Model of an Electro-Hydraulic Actuator System. *International Journal on Smart Sensing and Intelligent Systems*. 4: 440–453.
- [22] L. Ljung. 1999. *System Identification Theory for the User*. 2nd ed. CA: Linkoping University Sweden: Prentice Hall.
- [23] T. Soderstrom and P. Stoica. 1989. *System Identification*. Upper Saddle River, N. J. : Prentice Hall.
- [24] J. Pan, G. L. Shi, and X. M. Zhu. 2010. Force Tracking Control for an Electro-Hydraulic Actuator Based on an Intelligent Feed Forward Compensator. *Proceedings of the Institution of Mechanical Engineers Part C-Journal of Mechanical Engineering Science*. 224: 837–849.
- [25] H. E. Merrit. 1976. *Hydraulic Control System*. New York: Wiley.
- [26] T. L. Chern and Y. C. Wu. 1992. An Optimal Variable Structure Control with Integral Compensation for Electrohydraulic Position Servo Control Systems. *IEEE Trans Ind Electron*. 460–463.
- [27] A. Alleyne. 1996. Nonlinear force control of an electro-hydraulic actuator. In Proceedings of the Japan/USA Symposium on Flexible Automation. New York: ASME. 193–200.
- [28] G. A. Sohl and J. E. Bobrow. 1999. Experiments and Simulations on the Nonlinear Control of a Hydraulic Servosystem. *IEEE Transactions on Control Systems Technology*. 7: 238–247.
- [29] J. S. R. Jang. 1993. ANFIS: Adaptive-network-based Fuzzy Inference System. *IEEE Transactions on Systems, Man, and Cybernetics*. 23: 665–685.