

ACTIVE LOG PERIODIC ANTENNA

MOHAMAD KAMAL A. RAHIM

Abstract. This paper describes four different configurations of active devices integration into log periodic antennas (LPAs). The first configuration involves the integration of a single amplifier at the input feed line of a five element log periodic antenna (LPA). The second configuration involves the integration of an amplifier in the middle of the five elements LPA. The third configuration is the five element LPA with individual amplifiers in each element. The last configuration involves the integration of the individual amplifiers and filters with five element LPA in each element. The performance of these configurations have been investigated and compared in terms of the bandwidth, gain relative to a passive LPA, cross polar isolation and half power beamwidth.

Keywords: Log periodic antenna, active integrated antenna, microstrip antenna, wideband antenna

1.0 INTRODUCTION

Active integrated antennas receive a great deal of attention because they can reduce the size, weight, cost of the transceiver system and minimizes the connection losses. Due to the mature technology of microwave integrated circuit (MIC) and monolithic microwave integrated circuit (MMIC), the active integrated antenna becomes an area of growing interest in the recent years.

Active integrated antennas have many potential applications in wireless communications such as low cost and compact transceivers, detectors and sensors. Various antennas have been integrated into active devices that can be classified into oscillator type [1], amplifier type [2, 3] and frequency conversion type [4, 5].

A compact amplifier integrated antenna was reported by Robert *et al.* [2]. The transistor was directly integrated onto a microstrip patch antenna. An extra 8 dB gain was obtained at 1.68 GHz. A novel highly compact low noise amplifier was reported by Ormiston *et al.* [3]. This active integrated antenna provided a gain between 12 and 24 dB referred to a passive type of antenna at 1.35 GHz. Wu and Chang [6] described the configuration of dual FET active patch antenna element arrays for quasi-optical power combining. The circuit uses two FET's that symmetrically load a split patch antenna. An active microstrip patch antenna using an amplifying circuit was reported by An *et al.* [7]. In this configuration, two substrate layers with a ground plane in the

Wireless Communication Centre, Faculty of Electrical Engineering, Universiti Teknologi Malaysia 81310
UTM Skudai, Johor, Malaysia
Email: mkamal@fke.utm.my

middle were used. The microstrip antenna was built on one side of the ground plane and the amplifier was on the other side. The antenna was connected to the amplifier with a coupling probe through the ground plane. An increase of 24% in bandwidth in terms of transferred power gain was reported and at the same time, the input signal was amplified.

Ma *et al.* [8] investigated active antennas, which were implemented to act as direct conversion receivers. This active antenna can be applied for Doppler frequency detection, I and Q demodulation and direction finding. Their low power consumption and cheap manufacturing cost make this antenna suitable for short distance communication. An active integrated antenna with simultaneous transmit – receive operation was developed by Cryan and Hall [9]. The active antenna consists of a square microstrip patch antenna orthogonally connected to an oscillator and a receiving amplifier. Isolation of more than 45 dB between transmit and received was reported.

This paper discusses the development of active integrated log periodic antenna. Different configuration of integrating the amplifier has been studied. The performances of these antennas have been compared between the passive type of log periodic antenna. The result shows that the antenna has difference in performance for different configurations of integrating the antenna with an amplifier.

2.0 CONFIGURATION OF THE ACTIVE LOG PERIODIC ANTENNA

The integration of the active devices with the log periodic type antennas can be divided into four different configurations. The five element LPA has been chosen for the integration with the antenna and amplifier, in order to reduce the circuit complexity in the first evaluation of the concept.

The first configuration has a single amplifier connected at the input of the LPA [10]. In this configuration, the five element passive LPA works as an individual antenna with the amplifier integrated onto the same board. This configuration is shown in Figure 1.

The second configuration has a single amplifier embedded in the middle of the five element LPA. The amplifier can be connected either after two elements or three elements. For this work, the amplifier was connected after three elements. This configuration is shown in Figure 2.

The third configuration has an amplifier embedded into each individual patch. The amplifier is integrated at the inset feed of the antenna as described in Section 4.6. This configuration is shown in Figure 3.

The fourth configuration is the integration of an amplifier with an antenna and a filter. The amplifier is integrated at the inset feed and the filter is integrated at the input of every transmission line for each branch. This configuration is designed to avoid the buffering effect of the amplifier. When the amplifier is integrated into each individual patch and combined as an active LPA, the amplifier will work as a buffer. The band

pass filter is tuned to the same frequency as the antenna. Therefore, the power will be transferred to the antenna. This configuration will have a better log periodic action because the out of band mismatch of the filters can be used to create the right impedance environment to allow the appropriate antenna to be excited at each frequency as in the passive design process. This configuration is shown in Figure 4.

In general, the geometry of a frequency independent antenna is a multiplicity of adjoining cells. Each cell is scaled in dimensions relative to the adjacent cell by a factor that remains constant within the structure. The cells may be two or three dimensional. If L_n represents some dimension of the n^{th} cell and L_{n+1} is the corresponding dimension of the $(n+1)^{\text{th}}$ cell, then the relationship between adjacent cells can be stated as[11]:

$$\frac{L_{n+1}}{L_n} = \tau \quad (1)$$

The design principle for log periodic frequency independent antennas (FIAs) requires scaling of dimensions from period to period so that performance is periodic with the logarithm of frequency. This principle can be applied to an array of patch antennas. The patch length (L), the width (W) and Inset (I) are related to the scale factor τ by:

$$\tau = \frac{L_{m+1}}{L_m} = \frac{W_{m+1}}{W_m} = \frac{I_{m+1}}{I_m} \quad (2)$$

If all the dimensions of the array are multiplied by τ , it scales into itself with element m becoming element $m+1$, element $m+1$ becoming element $m+2$, etc.

This self-scaling property implies that the array will have the same radiating properties at all frequencies that are related by a factor of τ that is

$$f_1, \quad f_2 = \tau f_1, \quad f_3 = \tau^2 f_1, \quad f_4 = \tau^3 f_1 \quad \text{etc.} \quad (3)$$

We note that:

$$\ln \frac{f_2}{f_1} = \ln \tau, \quad \ln \frac{f_3}{f_1} = 2 \ln \tau \quad \text{etc.} \quad (4)$$

Hence τ is called the log periodic.

3.0 INTEGRATION OF AMPLIFIER AT THE INPUT FEED LINE OF LPA

This configuration is the simplest, where a single amplifier is integrated at the input of the LPA. The amplifier is biased with a voltage of 8.5 V with 40 mA biasing current. The dc blocking capacitor had to be put at the front to block the dc from going into

the measurement system. Figure 1(a) shows the configuration schematically used for circuit modeling. The layout of this configuration is shown in Figure 1(b).

The single element of the patch is scaled log periodically with a scaling factor of 1.05. Each individual antenna and the active device has an individual S_{11} parameter data file. The S-parameter data is exported to the schematic diagram as shown in Figure 8. The distance between element (m) and element ($m+1$) is determined according to the next higher frequency element of the antenna. The input looking into the next higher frequency must be open circuit before the next element ($m+1$) is connected to the schematic diagram. In this model, the distance between two patches is not necessarily half wavelength and varying log periodically. The microstrip antenna feed line is a quarter wavelength long. This value is scaled log periodically.

The inset feed distance of the microstrip antenna is chosen for 50 ohm input impedance and it is scaled log periodically. This model can be used for any element of log periodic patch antenna. The design of a quasi log periodic microstrip antenna can be carried out as follows:

- (i) Choose the first resonance frequency and scale it log periodically for the subsequent resonance frequencies.
- (ii) Calculate the patch dimension ($W=L$) for a square patch antenna and the inset feed dimensions for an input impedance of 50 ohm at the resonance and scale log periodically for the next patch.
- (iii) The distances between the branch lines are determined so that the input impedance looking into the next higher frequency is open circuit.
- (iv) The amplifier is connected to the input of the feed line of the LPA.

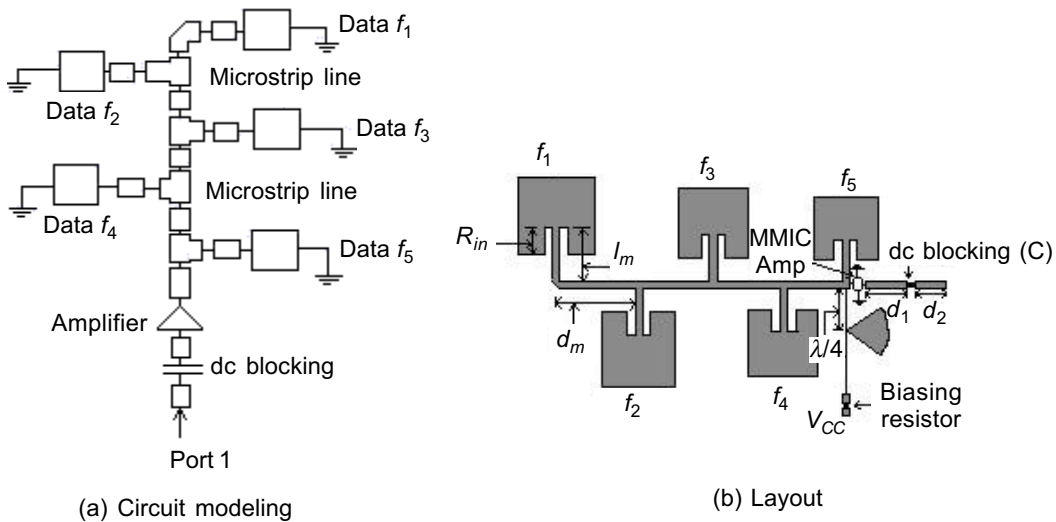

Figure 1 Circuit modeling and layout of the amplifier integration at the input feed

4.0 AMPLIFIER INTEGRATION AT THE MIDDLE PART OF LPA

The integration of an amplifier to the middle part of a five element LPA is shown in Figure 2. The amplifier is in the middle of the antenna between the third and fourth patches. In this design, the first three elements can be considered as the passive design. After placing the amplifier at the input of the third patch, the fourth element is considered as an active element design. The procedure to design for the fourth element is similar to the design of the passive element. At frequency f_4 and at the point of attachment of the fourth patch element, the input impedance to the amplifier should be open circuited. Therefore, the distance d_2 is adjusted to make that impedance as high as possible. The design process continues for the next element. Figure 2(a) shows the circuit modeling and Figure 2(b) shows the layout of the active antenna.

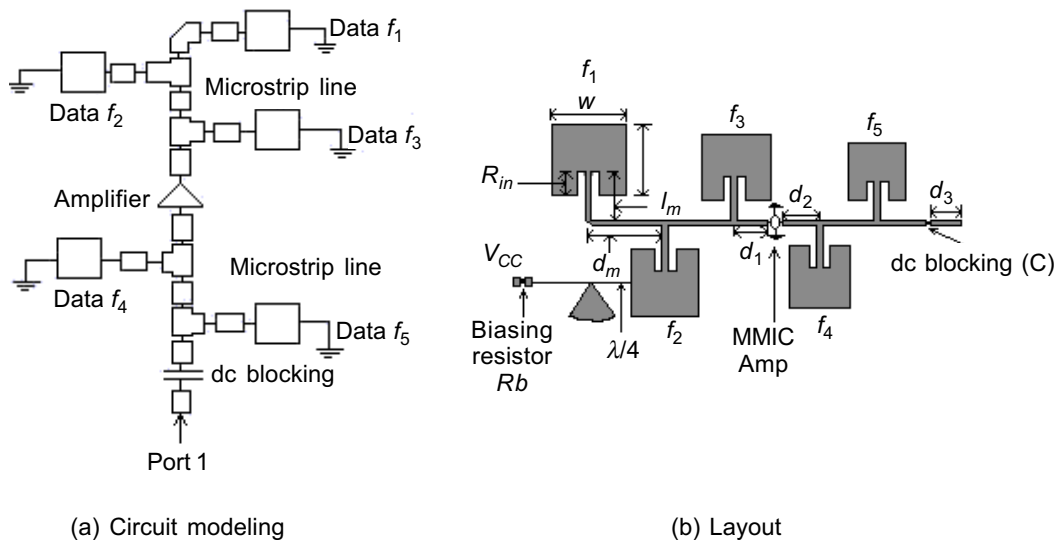

Figure 2 Circuit modeling and layout of integration of amplifier in the middle of LPA

5.0 AMPLIFIER INTEGRATION INTO EACH ELEMENT OF LPA

The configuration of the active LPA with individual amplifiers is shown in Figure 3. The amplifier is integrated at the inset feed of each antenna element. The biasing of the antenna is located at the centre of the non-radiating edge. At this edge, the impedance is zero. The biasing voltage for this configuration is 8.5 V with the total current of 200 mA. This is because, the drive current for each amplifier is 40 mA. So for five elements the total current is 200 mA. The dc blocking capacitor had to be put

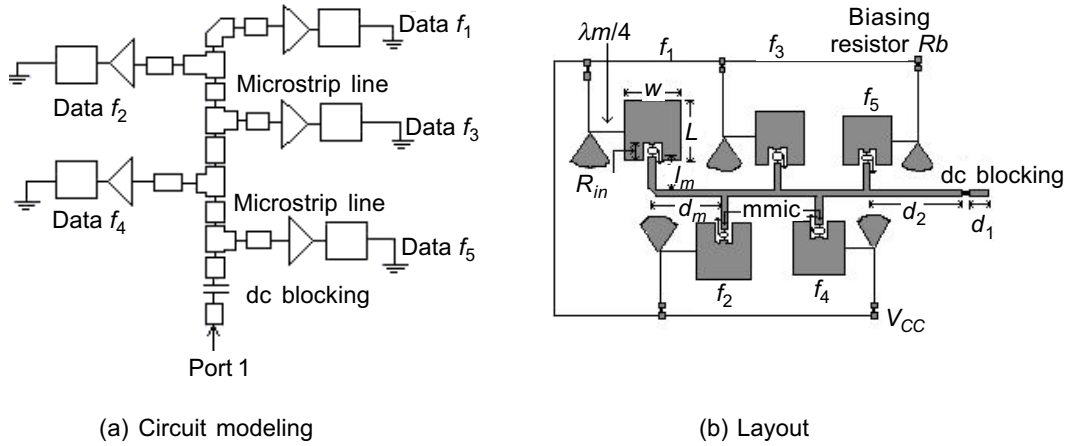

Figure 3 Circuit modeling and layout of amplifier integration into each element of LPA

in front of the feed network in order to block the dc voltage from reaching the measuring instrument. Figure 3(a) shows the circuit modeling and Figure 3(b) shows the layout of the circuit. The procedure to design this configuration is as follows:

- (i) Choose the first resonance frequency and scale it log periodically for the subsequent resonance frequencies.
- (ii) Calculate the patch dimension ($W=L$) for a square patch antenna and the resonance input impedance at 50 ohm and scale log periodically for the next patch.
- (iii) Amplifier is connected directly to the inset feed of the microstrip antenna and the return loss is obtained from the simulation.
- (iv) The distances between the branch lines are determined so that the input impedance looking into the next higher frequency is as near as possible to the open circuit.

6.0 AMPLIFIERS AND FILTERS INTEGRATION INTO EACH ELEMENT OF LPA

This configuration has been chosen in order to avoid the buffering effect on the log periodic active antenna when the amplifier is connected into the antenna without filter. The same procedure is applied when designing this circuit as was used for the passive LPA design. The band pass filter acts as a series LC filter tuned exactly to the frequency of the microstrip antenna. The effect of the filter will be to eliminate the buffering effect of the amplifier. The problem will arise when the tuning frequency is not the same as that of the patch antenna. Figure 4 shows the configuration of this active log periodic antenna.

Calculation of design parameters for square patch microstrip antenna is shown in Table 1. The substrate used is FR4 with dielectric constant of 4.7 and height of 1.6 mm. The scaling factor $\tau = 1.05$. The loss tangent of material is 0.019.

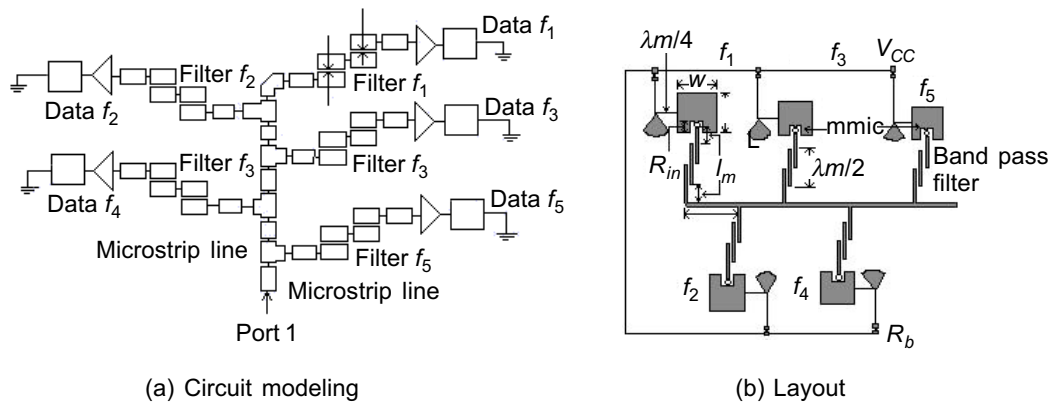

Figure 4 Circuit modeling and layout of amplifier and filters integration into each element of LPA

Table 1 Design parameters for log periodic antenna with scaling factor of 1.05

Data	Freq. (GHz)	$W=L$ (mm)	Quarter wave length (mm)	R_{in} (50 Ω) (mm)
f_1	2.73	25.34	14.40	8.20
f_2	2.87	24.13	13.70	7.80
f_3	3.01	22.98	13.04	7.50
f_4	3.16	21.89	12.45	7.20
f_5	3.32	20.84	11.83	6.90

7.0 RESULT AND DISCUSSION

The result of active log periodic antenna has been discussed in terms of the bandwidth response, radiation pattern characteristic, cross polar isolation and gain relative to the dipole and passive element for each configuration.

7.1 Amplifier Integration to the Input Feed Line of LPA

7.1.1 Bandwidth Response

The input return loss response of the integrated five element active LPA with amplifier at the input feed of the antenna is shown in Figure 5. The bandwidth of the antenna is 37% from the measurement and 28% from the simulation result. The simulation results give a good approximation for the measurement even though the frequency has been shifted slightly from the simulation result.

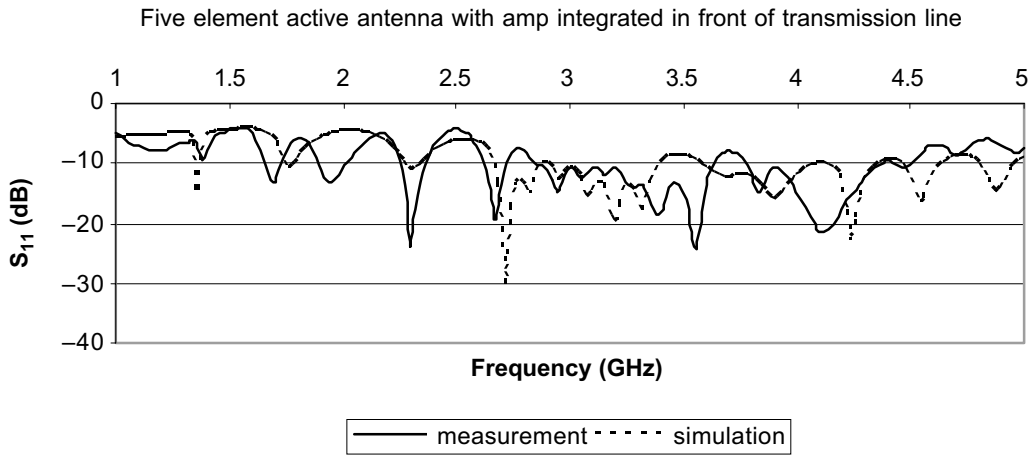

Figure 5 Input return loss

7.1.2 Co- and Cross-polar Isolation

The co- and cross-polar responses for this LPA are shown in Figure 6. In this measurement result, the cross-polar isolation is between 10 and 30 dB for a band of frequency from 2.5 to 3.6 GHz. The cross-polar isolation is more than 30 dB at the frequency of 2.75 GHz. At 3.4 GHz, the cross-polar isolation is minimum.

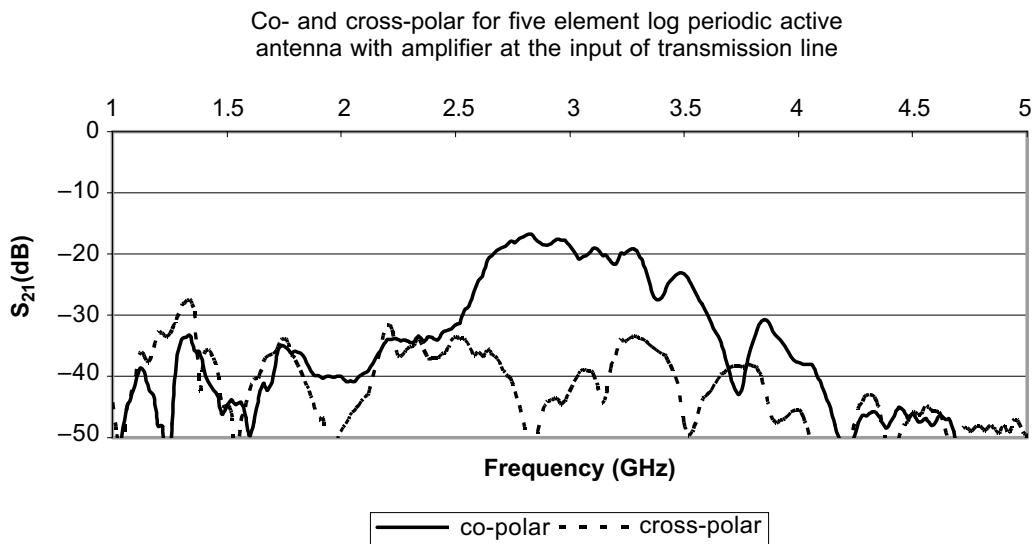

Figure 6 S_{21} response for active LPA

7.1.3 Comparison with Passive LPA

The comparison between the active and passive five element LPAs is shown in Figure 7. The gain of the active antenna varies from 5 to 9 dB relative to the passive antenna. At frequency of 2.5 GHz, the gain is nearly 7 dB. The gain is steadily constant at frequency 2.6 GHz to 3.4 GHz. The lowest gain is at 3.35 GHz where the relative gain of the active antenna is 5 dB. The BW from this measurement is nearly 38% with a centre frequency of 3.1 GHz. The response from the active antenna follows the response from the passive antenna with the same fluctuation.

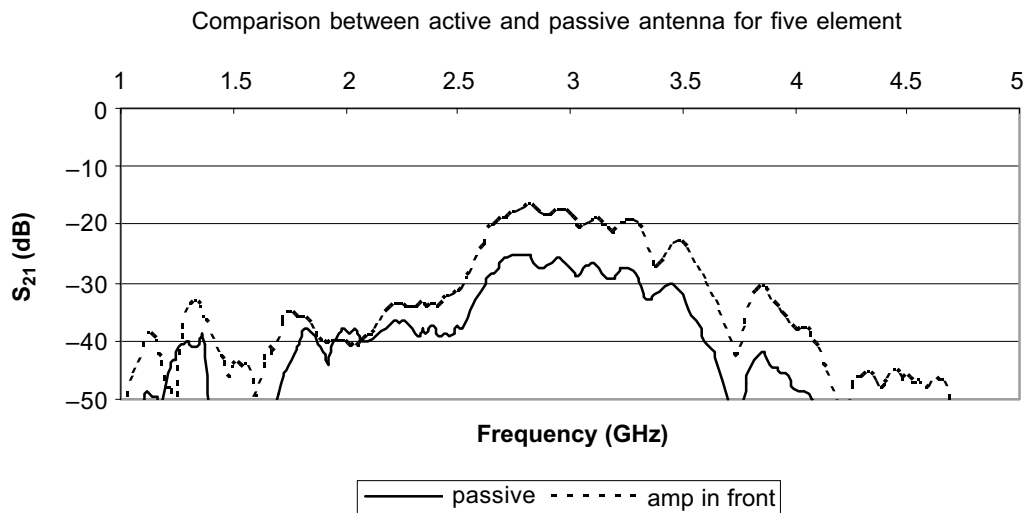

Figure 7 S_{21} response relative to passive LPA

7.1.4 Radiation Pattern Characteristics

The radiation pattern is in the broadside direction. In the H plane, the radiation pattern remains nearly the same over the entire BW. However in the E-Plane, the radiation pattern varies with the frequency. The HPBW for the E-plane is smaller than for the H plane. At the frequency of 2.55 GHz, the cross-polar isolation for E and H-plane is only 8 dB. The HPBW for E-plane is 30° , which is tilting to the right from the broadside direction and 60° for the H-plane. The radiation pattern at the middle frequency of 3.05 GHz has a cross polar isolation of 25 dB for E-plane and 30 dB for H-plane. At the frequency of 3.50 GHz, the cross-polar isolation is 20 dB for the E-Plane and 21 dB for the H-Plane. The HPBW at this frequency is 40° for the E-plane and 60° for the H-plane.

7.2 Amplifier Integration into the Middle of the Amplifier

7.2.1 Bandwidth Response

The input return loss from measurement and simulation is shown in Figure 8. The BW of this antenna at 6 dB return loss is 27% from the measurement and 31% from the simulation results. The return loss is lower in the middle because of the effect of the amplifier integration.

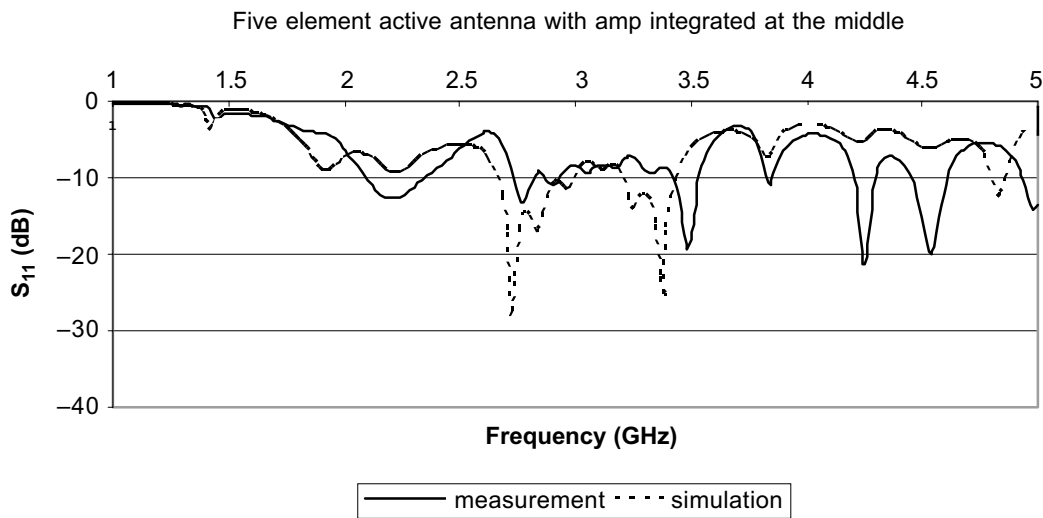

Figure 8 Input return loss

7.2.2 Co- and Cross-polar Isolation

Figure 9 shows the co- and cross-polar responses for this configuration. The co-polar response indicates a 3 dB gain of 0.7 GHz centred on 2.95 GHz. The cross-polar isolation is around 20 dB or more over that frequency range.

7.2.3 Comparison with Passive LPA

The comparison between the passive and active antenna is shown in Figure 10. The active antenna has a gain of 10 dB relative to the passive LPA. From 2.6 to 3.2 GHz, the gain is nearly 10 dB relative to the passive antenna. This is because the amplifier has increased the signal at the lower frequency.

Co- and cross-polar for five element log periodic active antenna with amplifier in the middle

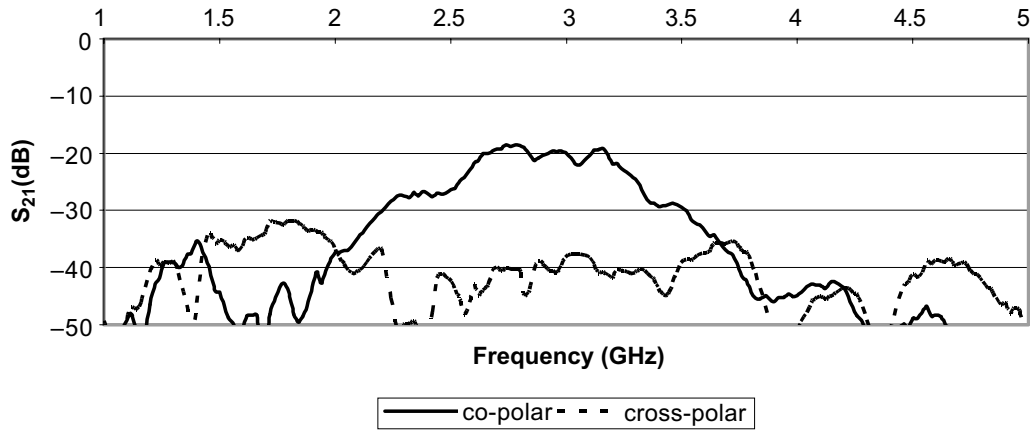

Figure 9 Co- and cross-polar isolation

Comparison between active and passive antenna for five element

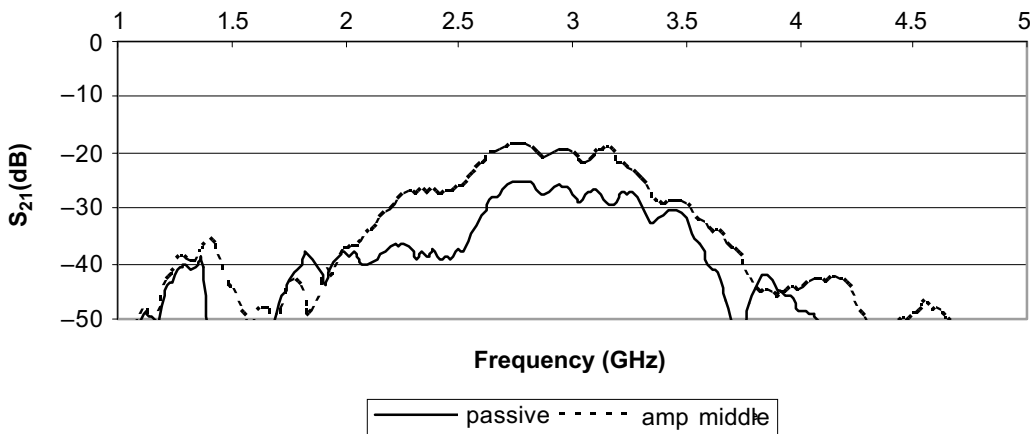

Figure 10 S_{21} response relative to passive

7.2.4 Radiation Pattern Characteristic

The radiation is at the broadside direction of the antenna. In the H-plane, the radiation patterns remain nearly the same over the entire BW. The radiation pattern is slightly shifted from the broadside direction at a frequency of 2.90 GHz and 3.05 GHz. In the E-plane, the radiation patterns have smaller HPBW compared with the H-plane. At lower frequency 2.55 GHz, the cross-polar isolation for the E-plane is 20 dB and the H-plane is 18 dB. The HPBW for the E-plane and H-plane are 70° . The radiation

pattern at the middle frequency of 3.05 GHz has a cross polar isolation of 20 dB for the E-plane and 18 dB for the H-plane. The HPBW at this frequency is 60° for the E and H-plane. For the highest frequency at 3.50 GHz, the cross-polar isolation is 10 dB for the E-plane and H-plane. The HPBW at this frequency is 30° for the E-plane and 65° for the H-plane.

7.3 LPA with Individual Amplifiers Integrated into Each Element

7.3.1 Bandwidth Response

The input return loss characteristic for the measurement and simulation is shown in Figure 11. The bandwidth obtained from the measurement result is 33% and the simulation result has a bandwidth of 36%. The simulation results give a good approximation for the measurement even though the frequency has been shifted slightly from the simulation result.

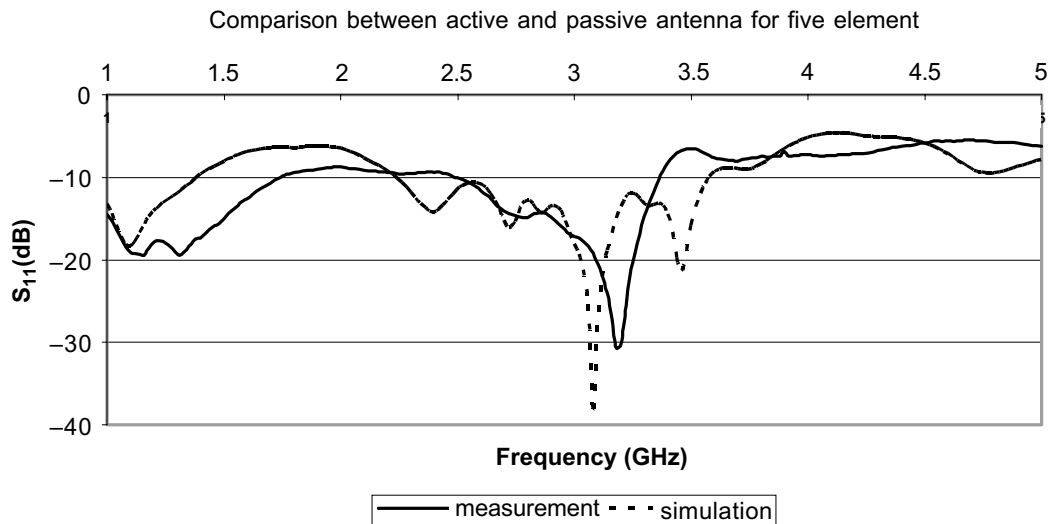

Figure 11 Input return loss

7.3.2 Co- and Cross-polar Isolation

The cross-polar isolation throughout a band of frequency from 2.6 to 3.6 GHz is between 5 dB and 18 dB. Figure 12 shows the co- and cross-polar response. The lowest cross-polar isolation is at 2.7 GHz and the highest cross-polar isolation is at 3.4 GHz which is 5 dB and 18 dB respectively.

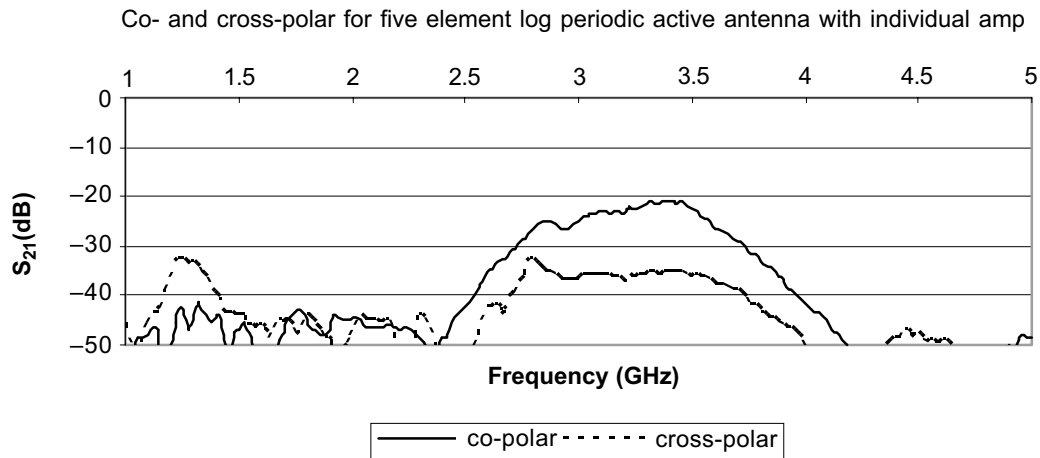

Figure 12 Cross polar isolation

7.3.3 Comparison with Passive LPA

The comparison between passive and active LPA is shown in Figure 13. The S_{21} shows that frequency has been shifted to the higher end. It has been shifted to 3.5 GHz with a gain of 10 dB. At lower frequencies, the active antenna has lower gain compared with the passive antenna. The gain is between -2 and 0 dB. It starts to increase at a frequency of 3 GHz with a gain of 5 dB. The highest gain is at 3.5 GHz where this antenna has a gain of 10 dB compared to the passive antenna.

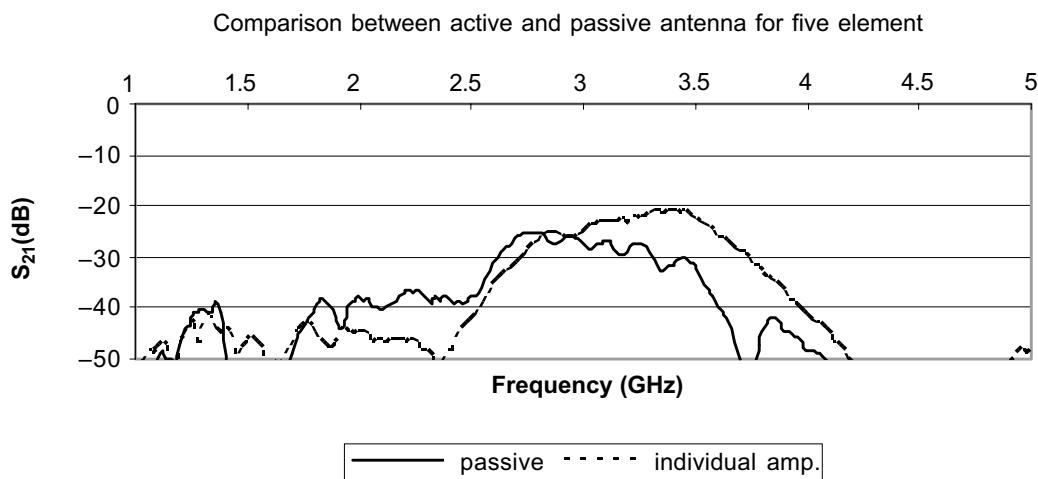

Figure 13 S_{21} response relative to passive

7.3.4 Radiation Pattern Characteristic

The radiation is in the broadside direction. In the H-plane, the radiation pattern remains the same at a lower frequency. When the frequency increases, the HPBW of the H-plane is smaller than the E-plane. The cross-polar isolation for this configuration is between 20 and 30 dB at frequencies from 3.05 to 3.5 GHz. At lower frequency, 2.55 GHz, the cross-polar isolation for the E-plane is only 2 dB and the H-plane is 10 dB. The HPBW for the E-plane and H-plane is 60° . The radiation pattern at the middle frequency of 3.05 GHz has a cross-polar isolation of 20 dB for the E-plane and H-plane. The HPBW at the middle frequency is 50° for the E and H-plane. For the highest frequency of 3.50 GHz, the cross-polar isolation is 18 dB for the E-plane and 28 dB for the H-plane. The HPBW at this frequency is 45° for the E-plane and 65° for the H-plane.

7.4 Active Five Element LPA with Individual Amplifiers and Filters

7.4.1 Bandwidth Response

The input return loss from the measurement and simulation is shown in Figure 14. The bandwidth of the measured result is 25% and the simulation results give a bandwidth of 26%. The simulation results give a good approximation for the measurement even though the frequency has been shifted slightly from the simulation result.

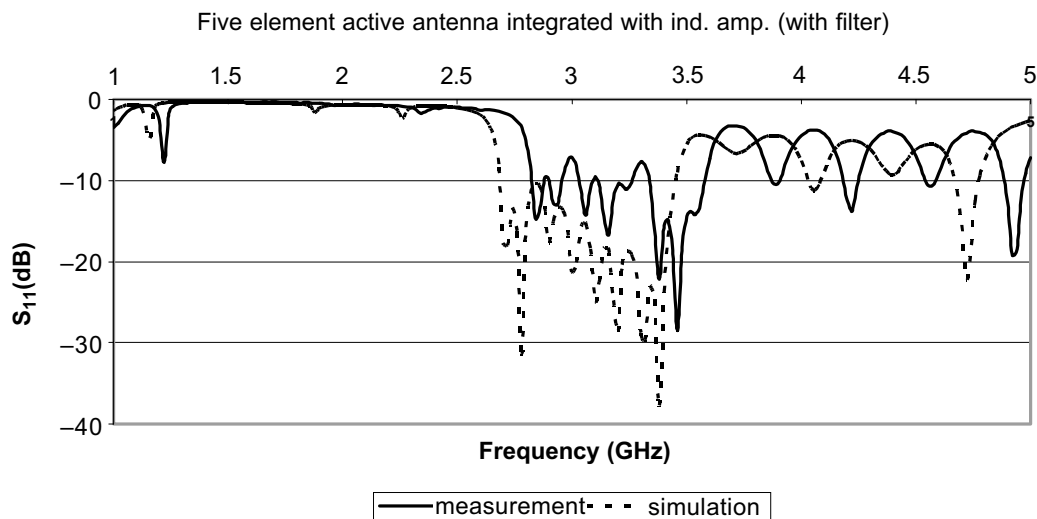

Figure 14 Input return loss

7.4.2 Co- and Cross-polar Isolation

The co- and cross-polar responses are shown in Figure 15. The cross-polar isolation is only 5.0 to 10 dB. This is because of the effect of stray radiation from the narrow band filters. At a frequency of 3.1 GHz, the cross-polar isolation is minimum. The only frequency range value the LPA has a good cross-polar isolation is from 3.4 to 3.5 GHz. The frequencies of the filter and the corresponding antenna coincide well. Most of the power is delivered to the antenna and radiated, and the radiation from the filter is minimized.

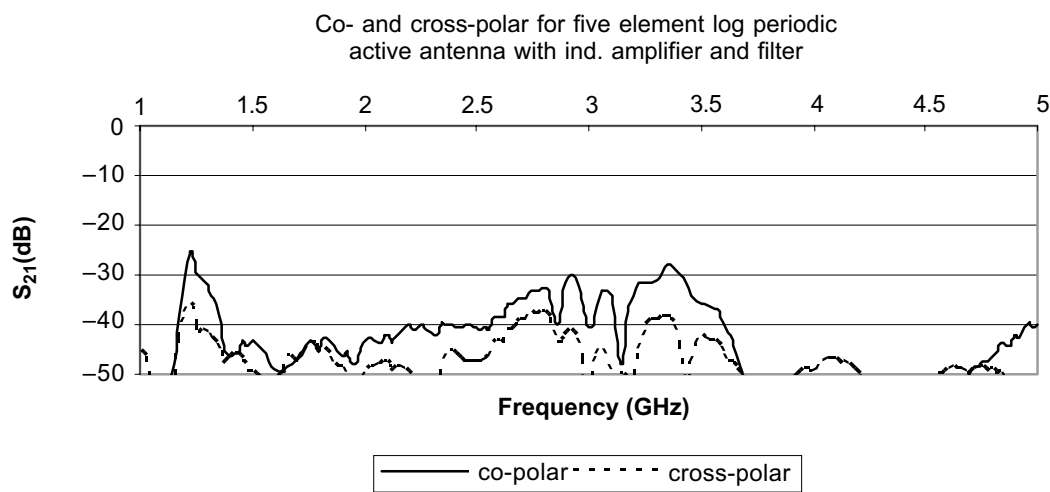

Figure 15 Co- and cross-polar isolation

7.4.3 Comparison with Passive LPA

Figure 16 shows the comparison between the active and passive LPAs. The result obtained shows that active LPA has slightly lower gain than the passive LPA. This is the effect of filtering from the band pass filter and the insertion loss of the filter. This response is only good at a frequency of 3.4 GHz. This happened because the antenna at the feeding point is at a higher frequency. Therefore, the power loss through the filters is smaller compared to the lower frequency.

7.4.4 Radiation Pattern Characteristic

The radiation pattern characteristics show that the pattern has been changed from one frequency to the other at various measurement frequencies. In the H-plane, the radiation pattern has 3 lobes at frequency 3.12, 3.18, 3.25 and 3.32 GHz. However in the E-plane,

Comparison between active and passive antenna for five element

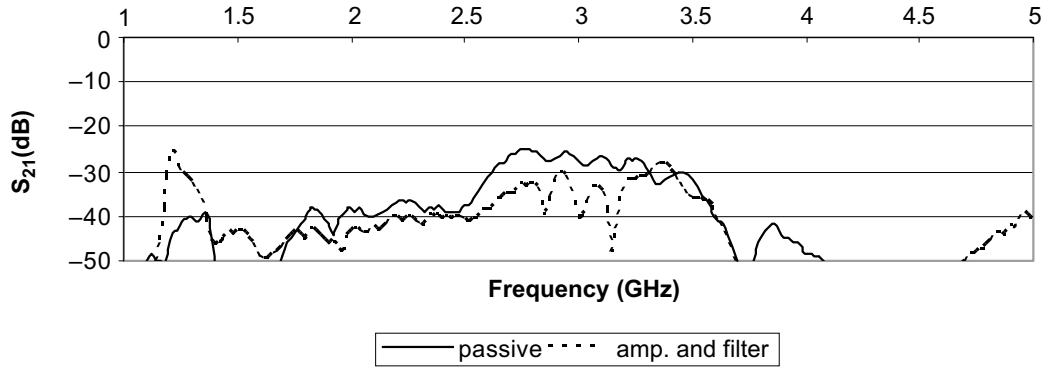
**Figure 16** S_{21} response relative to passive

the beam is directed towards broadside direction with a distortion of the radiation pattern. At lower frequency of 2.55 GHz, the cross-polar isolation for the E-plane is 10 dB and the H-plane is 12 dB. The HPBW for the E-plane is 20° and the H Plane is 90° . The radiation pattern at the middle frequency of 3.00 GHz has a HPBW of 10 dB for the E-plane and 5 dB for the H-plane. At 3.50 GHz, the cross-polar isolation is 10 dB for the E-plane and 12 dB for the H-plane. The HPBW at this frequency is 35° for the E-plane and 100° for the H-plane.

Table 2 describes the advantages and disadvantages of different configurations of active LPA.

Table 2 Advantages and disadvantages of active LPA

Configurations	Advantages	Disadvantages
Integration of amplifier at the input of feed line LPA	<ul style="list-style-type: none"> • Simple method of introducing gain 	<ul style="list-style-type: none"> • No gain slope compensation
Integration of amplifier in the middle of LPA	<ul style="list-style-type: none"> • Broader gain bandwidth • Reduced gain slope in the lower frequency range 	<ul style="list-style-type: none"> • Enhances gain at lower frequency end more than at higher frequency
Integration of amplifier into each element of LPA	<ul style="list-style-type: none"> • Higher gain at higher frequency end • Could be adapted to achieve flat overall gain • Reduced gain ripple 	<ul style="list-style-type: none"> • Low gain at lower frequency end • Poorly defined S_{11} bandwidth due to buffering effect
Integration of amplifiers and filters into each element of LPA	<ul style="list-style-type: none"> • Conventional LPA impedance relationships are restored by removing amplifier buffering • Elimination of harmonic antenna response 	<ul style="list-style-type: none"> • Very hard to make BPF and patch resonant frequencies coincide • Excessive loss and radiation due to filters

8.0 CONCLUSION

Amplifier integrating to the front of an array introduces signal gain without reducing the bandwidth. Integrating an amplifier in the middle of the feed line appears to offer some potential increase in the bandwidth and introduces additional gain for the array, but it also introduces a negative gain slope vs. frequency.

Integrating individual amplifiers with each antenna element works well at the upper frequency limit but the buffering effect makes the gain response difficult to be achieved. This configuration showed a positive gain slope vs. frequency. Further optimisations may be possible to achieve an overall flat gain response.

Filters in front of each amplifier element potentially solve the buffering problem but are too lossy as a planar structure and too hard to tune to coincide with the antenna element frequency. Stray radiation from the filter degrades the antenna pattern.

REFERENCES

- [1] Andrews, J. W. and P. S. Hall. 2002. Phased Locked Loop Control of Active Microstrip Patch Antennas. *IEEE Trans. on Microwave Theory Tech.* 50(1): 201-206.
- [2] Robert, B., T. Razban, and A. Papiernik. 1992. Compact Amplifier Integration in Square Patch Antenna. *Electronic Letter.* 28(19): 1808-1810.
- [3] Ormiston, T. D., P. Gardner, and P. S. Hall. 1998. Compact Low Noise Receiving Antenna. *Electronic Letter.* 34(14): 1367-1368.
- [4] Chang, K., R. A. York, P. S. Hall, and T. Itoh. 2002. Active Integrated Antennas. *IEEE Trans. on Microwave Theory Tech.* 50(3): 937-943.
- [5] Lin, J. and T. Itoh. 1994. Active Integrated Antennas. *IEEE Trans. on Microwave Theory Tech.* 42(12): 2186-2194.
- [6] Wu, X. D. and K. Chang. 1995. Dual FET Active Patch Elements for Spatial Power Combiners. *IEEE Trans. on Microwave Theory Tech.* 43(1): 2630.
- [7] An, A., B. Nauwelaers, and A. Van De Capelle. 1991. Broadband Active Microstrip Array Elements'. *Electronics Letters.* 27(25): 378-379.
- [8] Ma, G., P. S. Hall, P. Gardner, and M. P. Hajian. 2001. Active Integrated Antennas Using Direct Conversion Detection. *International Conf. on Antennas and Propagation.* 2: 475-477.
- [9] Cryan, M. J. and P. S. Hall. 1996. Integrated Active Antennas with Simultaneous Transmit-receive Operation. *Electronic Letter.* 32(14): 286-287.
- [10] Rahim, M. K. A. and P. Gardner. 2004. Active Microstrip Log Periodic Antenna. *RF and Microwave International Conference.* 136-139.
- [11] Mayes, P. E. 1992. Frequency Independent Antennas and Broad Band Derivatives Thereof. *Proc. of the IEEE.* 80(1): 103-112.
- [12] Garg, R., P. Bhartia, I. Bahl, and A. Itlipiboon. 2001. *Microstrip Antenna Design Handbook.* Norwood, USA: Artech House Inc.
- [13] Balanis, C. A. 2005. *Antenna Theory: Analysis and Design.* 3rd edition. New York: John Wiley & Sons Inc.