

Process Sequence Development for Automated Progressive Freeze Concentration System

Nor Zanariah Safiei, Mazura Jusoh*

Faculty of Chemical Engineering, Universiti Teknologi Malaysia, 81310 UTM Johor Bahru, Johor, Malaysia

*Corresponding author: mazura@cheme.utm.my

Article history

Received :10 March 2014
Received in revised form :
28 April 2014
Accepted :15 May 2014

Graphical abstract

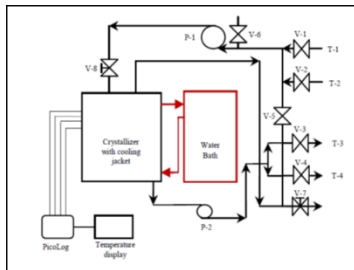

Abstract

Nowadays there is a growing interest on Progressive Freeze Concentration (PFC) in solution concentration process due to its several significant advantages. The PFC process is proven to be able to be applied successfully in industrial application. PFC often exhibits a dynamic character and involves complex behavior and process. Even a slight change in the operating condition can cause unstable process behavior and lead to low performance of the system. Due to these reasons, the objective of this paper is to develop a sequence for conducting PFC process. In order to develop the process sequence, it has been divided into four major steps which are feeding process, crystallization process, Product 1 collection and Product 2 collection. This system offers improved overall performance in conducting experiments as well as increased efficiency of the separation process.

Keywords: Freeze concentration; progressive freeze concentration; solution concentration process; industrial application, control and process sequence

© 2014 Penerbit UTM Press. All rights reserved.

1.0 INTRODUCTION

Many industrial processes consist of a concentration step for instance as a pre-concentration step for filtration, crystallization and drying. The major objective of concentration process is to reduce excess energy load in the subsequent operation or to augment concentration level available for carrying out subsequent processing.¹ Furthermore, in certain industries such as fruit juice industry, the concentration of solution is carried out because it involves a volume reduction in the processed products which allows important savings in transport, storage and packing costs.²

Freeze concentration (FC) has emerged as an interesting alternative to conventional processes in solution concentration field in terms of both the construction and operation of the equipment.¹ The principle of FC is based on the solidification phenomena of water. When a crystallized ice appears and grows from solution, the ice crystal expels impurities to build up pure crystal during freezing process. Thus the impurities are accumulate in the liquid phase to increase the concentration of the mother liquor.³ The purging of pure water is enabled by the nature of the crystal lattice build up from an aqueous solution or suspension at temperatures lower than its melting point, rejecting all impurities that would remain in the mother liquor.⁴ The crystal lattice formed consists of

crystallographic arrangement of water molecules that bond with positive charge concentration of one molecule attached to another negative charged. This purely electrostatic attraction energy is very strong and plays a major role in building the ice crystal structure. Due to the strong affection between the water molecules, other molecules are rejected and cannot be part of the ice crystal lattice.⁵

As compared to conventional solution concentration methods that are already established such as evaporation and membrane technology, FC has some significant potential advantages for producing high quality of products. Since the process occurs at low temperature range (-6°C to -14°C), no vapor/liquid interface exists and high retention of thermal sensitive compounds can be performed resulting in no loss of volatiles components and producing high quality of products.⁶ Furthermore, FC also involves low energy (0.33 kJ/g-water) demand and prevents changes in chemical and biochemical properties in products.⁷ Constraints of other conventional methods discussing environmental and economic issues are also leading to a greater interest in FC process. These benefits make FC particularly suitable for the concentration of some products, such as fruit juices, coffee and tea extracts, and aroma extracts. Other applications that have been tested with this method are such as milk and saline solution⁸ and lime juice.⁹

1.1 Suspension Freeze Concentration

Basically FC process is initially discovered based on the Suspension Freeze Concentration (SFC) where small ice crystals are formed in mother liquor and producing slurry solution. A typical SFC process is composed of three processing units which are ice nucleator, a recrystallizer and ice crystal separator. Ice nucleator normally used in SFC is the scraped surface heat exchanger (SSHE) to generate ice nuclei and to maintain high heat transfer by scraping the ice layer formed. The small size of ice crystals are formed from ice crystal scraping. Therefore an additional step is needed in order to increase the size of ice crystals thus increase the process complexity. Furthermore, due to the large surface area of small ice crystals, the product obtained is not highly pure and increase the difficulty to separate it from mother liquor.¹⁰ Other than that, the SSHE that is normally used in SFC process is the most expensive type of heat exchanger, leading to high capital cost. Thus SFC is considered as the most expensive method among existing concentration methods.¹¹

1.2 Progressive Freeze Concentration

On the contrary, improved method of FC which is Progressive Freeze Concentration (PFC) is discovered by Matthews and Coggeshall in 1959, in which a single ice crystal is formed on the cooled surface.¹² PFC is applying the same concept with SFC but the major difference between these two methods is the size of ice crystal formed. The target solution that needs to be concentrated flows over a cooled surface, which causes crystallization process of ice occurs on the surface. Further growth of ice crystal is produced in layer. The large size of ice crystal produced resulting in lower surface area and less impurities is trapped at the ice-liquid interface. The separation of ice occurs when concentrated solution is collected and flushed while the ice crystal adheres to the surface making the separation process easier.¹³ Since the process is involving less unit operations, hence it is expected that the process to be much simpler and lowering initial investment compared with previous method.

Due to the simpler operation and high quality of products offered by the PFC process, it has high opportunity to be applied in industrial application. There are quite a number of designs of crystallizers proposed in previous researches but the designs are still in lab scale and require further research. The designs proposed are such as vertical vessel,¹⁴ stainless steel plate,¹⁵ aluminium plate heat exchangers,¹⁶ vertical aluminum tube,¹⁷ ballon flask,¹⁸ square pillar,¹⁹ stainless steel cylindrical vessel,²⁰ tubular ice system,²¹ multiplate cryoconcentrator,²² and the latest design, dynamic layer melt crystallizer.²³

Although PFC is proven to be effective for high quality concentration of liquid food, the productivity of this method is much lower as compared to the SFC method. Therefore, a tubular ice crystallizer was proposed by Miyawaki *et al.*²¹ in which the ice crystal grows on the inside surface of a pipe being cooled by a coolant. This way, the productivity was easily increased simply by increasing the surface area of the cooling plate. Numbers of pipes can be bundled together and interconnected in series to increase the cooling surface area more.

Successful commercial applications of SFC and PFC process have been tried in several industries such as petroleum and food products but it is not widely establish yet due to the lack of systematic investigation on the mechanism of concentration and separation efficiency of the process.²⁴ New opportunities have arisen in waste water treatment, chemical processing, desalination and pulp industries. Therefore, it is required to develop a precise and simple automation of PFC process.²⁵ There are several disadvantages of PFC process that hinder it from

commercialization in larger scale. Many engineering problems are encountered especially in the development work with high capital cost, operation cost and electricity.

In this paper, a process sequence for PFC is proposed to acquire high performance system in terms of operation time, no intervention of human operator and most importantly production of high quality of product. Strategy of conducting the complex process is to make it simpler by introducing timeline for every sub process involved in the process. The timeline for automation of PFC process proposed is basically suitable for helical crystallizer because the time range proposed is based on capacity of raw material and size of the mentioned crystallizer.

The proposed sequence of sub processes for PFC could be a starting point and guide for future action that would be used to the next stages of operation of the large pilot plan study and field testing toward commercialization step. Assisted sequences and techniques that improve the efficiency of processing in one-step configurations of PFC are important in achieving commercial viability.

2.0 METHODS

2.1 General Considerations

A sequence of PFC process has been introduced to explain the sub processes involved in automation associated with crystallization process. It is designed to assist the implementation for better management in conducting the process. Since PFC is suitable for several applications; thus glucose solution is used as a simulated solution to represents the real solution used in industry. The coolant solution used is the Ethylene Glycol-Water (EGW) mixture containing 50% of Ethylene Glycol by volume (v/v). The ratio is chosen based on suitable freezing range for helical crystallizer in designated time for freezing.

2.2 Crystallizer's Design

A helical crystallizer is chosen to be used in this research due to its main advantage which is high productivity. One cycle of experimental run is using approximately 2 L of target solution and could easily be increased according to product demand. Helical crystallizer is proven to give 9 times higher surface area for ice formation compared to conventional crystallizer for the same diameter tube. Helical crystallizer is still in lab scale and lacks of automation feature, thus it still requires manual handling and involves physical constraint. There are some technical limitations that need to be overcome when conducting the experiment.

Table 1 shows the dimension of the helical crystallizer and Figure 1 shows the crystallizer equipped with cylindrical cooling jacket where inlet and outlet of the crystallizer are facing upward. At the sides of the top and bottom cooling jacket, inlet and outlet for coolant overflow are provided to assist circulation of the coolant solution with the water bath.

Table 1 Dimension of helical crystallizer

Material	Stainless steel
Height	35.5 cm
Internal Diameter	2.54 cm
Wall thickness	0.8 mm
Total Length	237 cm
Internal Volume	1135 mL



Figure 1 Crystallizer equipped with cylindrical cooling jacket

In the cooling jacket, eight thermocouples (type K) were installed at all cycles of the crystallizer to measure the temperature distribution of coolant solution and target solution. All the thermocouples were custom-made so that they fit to the crystallizer and to ensure precise measurement of temperature tabulation around crystallizer. The temperatures measured were displayed through a computer connected via a data acquisition tool, PICOLog. The temperature was taken at every second throughout every cycle of experiment and temperature profiles were analyzed. The cooling jacket was insulated with polyurethane foam to minimize heat disturbance from ambient temperature.

2.3 Design Principle of Automated PFC Process

Figure 2 and Figure 3 show the schematic diagram and the rig of the PFC automated system where it consists of helical crystallizer equipped with cooling jacket as the main element respectively. Suitable pumps and valves were installed to assist the system. There are two types of pump used in PFC prototype. One is a peristaltic pump (P-1) and the other is a diaphragm pump (P-2). Peristaltic pump is used to provide force to circulate the solution in the pipeline. One of the advantages of peristaltic pump is its ability to safely conduct a dry run and there will be no damage to any parts of the pump as well as the target solution.

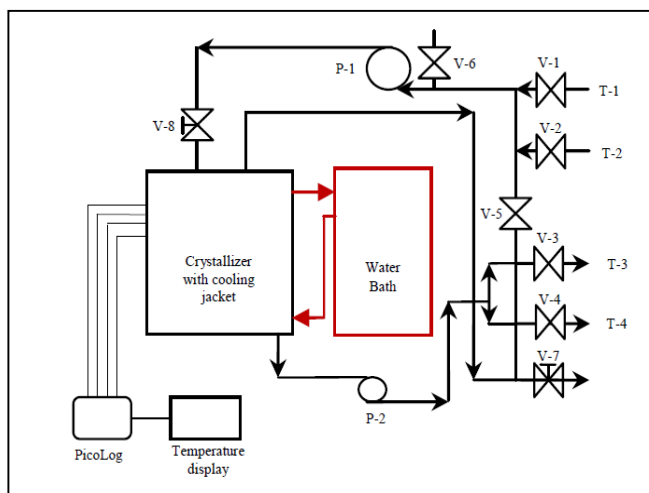

Figure 2 Schematic diagram of the PFC automated system



Figure 3 PFC automated system rig

Stainless steel pipe was used to transfer target solution and products between tanks and crystallizer. Six solenoid valves and two ball valves were used to control the flow of solution in the system. There were two different orifice valves used which are 3 mm and 2.5 mm. The bigger size orifice was used for V-1 and V-5 where both of them were installed for feeding and crystallization step in order to produce high flowrate or quick dump and fill capacity. Tank 1 (T-1) and Tank 2 (T-2) were installed to store target solution and hot water for flushing respectively. Meanwhile Tank 3 (T-3) and Tank 4 (T-4) for Product 1 (concentrate) and Product 2 (thawed ice) collection respectively were also installed. The system was also equipped with a camera located the end of the second cycle of the crystallizer in order to enable the visualization of real situation inside the crystallizer during crystallization process via a screen attached at the panel.

3.0 RESULTS AND DISCUSSION

3.1 Process Sequence Development

To produce one batch of an automated PFC system process, a sequence of four major steps has to be performed which are feeding process, crystallization process, collection of Product 1 (concentrate) and Product 2 (thawed ice). This development is carried out in order to allow PFC process to be more effective.

Figure 4 shows the functions for the equipments involved in the development of PFC system and the range of temperature distribution desired in the cooling jacket. Recirculation pump (P-1) is installed to supply the driving force to transfer solution in the system. Eight valves are used which are V-1, V-2, V-3, V-4, V-5, V-6, V-7 and V-8. V-1 connects Tank 1 with the crystallizer for target solution and V-2 is connecting Tank 2 with crystallizer for hot water. V-3 and V-4 are connecting the crystallizer with Tank 3 and Tank 4 respectively for product collection meanwhile V-5 is installed to allow solution to circulate in the system. V-6 and V-8 are installed to assist solution flow and V-7 helps to remove unwanted waste remaining in the system. The arrow in the table in Figure 4 for all equipment shows the time range for the equipments to operate where the time for each process can be varied between 1 to 99 minutes.

The major challenge in the presented process sequence in PFC is to control and stabilize the temperature distribution in the cooling jacket. Fast response of temperature changes is needed to give high performance system since the crystallization process is majorly

dependent on the temperature. Good temperature distribution in cooling jacket is needed to ensure high quality product obtained during the process. According to Figure 4, temperature is cooled down to -10°C for crystallization process. After collection of Product 1, the temperature is increased to certain temperature (~25-30°C) for ice thawing process by increasing the coolant temperature in the water bath.

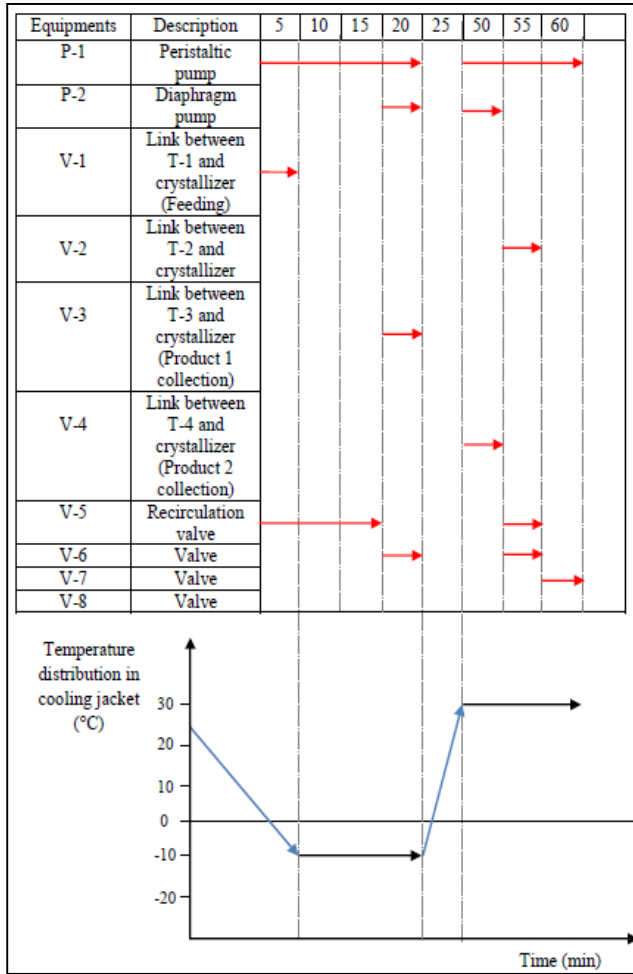

Figure 4 PFC system process sequence

Figure 5 shows the process timeline and action taken by peristaltic pump and valves for every sub process involved. Time delay proposed for each process is 5 minutes according to suitable capacity and condition of the helical crystallizer and can be adjusted accordingly.

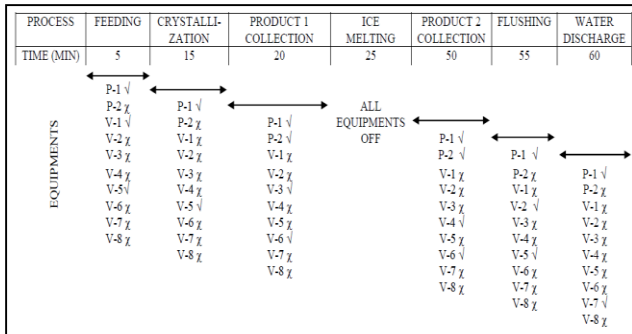

Figure 5 PFC system timeline

Flowrate of target solution and coolant solution are set at 3000 mL/min and 13 L/min respectively. Higher flowrate of target solution will give higher efficiency of the process. Firstly, feeding process is performed by transferring the target solution (raw material) from Tank 1. For the process, P-1 is turned on while V-1 and V-5 are opened. V-1 allows for the transference of the target solution from Tank 1 to crystallizer.

Before starting the process, coolant temperature in the water bath as well as in the cooling jacket is cooled down to the desired value (-10°C). The temperature distribution is constantly monitored through PICOLog data. V-1 is located close to Tank 1 to allow the target solution to be flushed from the valve when necessary to shut off the target solution flow. P-1 provides driving force for the target solution to reach the crystallizer meanwhile V-5 allows the target solution to flow in the circulation pipe. Time delay for 5 minutes is applied until the solution fills the volume of crystallizer and the pipe. Then, crystallization process is performed. During crystallization process, P-1 is turned on while V-5 is opened. Target solution is kept circulated in the circulation line. During the process, water component will crystallize on the crystallizer's wall in a layer form, thus the pressure in the crystallizer begins to rise. A relief valve is installed at the crystallizer outlet as precautions to avoid overflow of the target solution. Maximum time for crystallization process for helical crystallizer is approximately 20 minutes.

Then, the third process involved is the collection of Product 1 (concentrate). During this process, V-3 is opened for 5 minutes to allow flows of the Product 1 from crystallizer to Tank 3. V-5 is closed to prevent the Product 1 flows back to the crystallizer. Since the outlet of crystallizer is facing upward, there is difficulty in pumping the entire Product 1 in the crystallizer to be collected where the push force provided from P-1 is not enough. Therefore, a small path was added at the lowest point at the end of the lowest cycle of crystallizer to assist the collection. Besides, a heater tape is wrapped around the small path to ensure there is no ice formed in the path during the submergence in the extreme temperature. A diaphragm pump (P-2) is installed to assist the collection. Moreover, as the collection Product 1 starts, temperature of coolant is increased to enable the ice thawing process to occur. Time taken to increase the coolant temperature is approximately 20 to 30 minutes. After all of the ice crystal is being thawed, Product 2 (thawed ice) collection process is performed. V-4 is opened to allow the transference of Product 2 from crystallizer to Tank 4. Again, V-5 is closed to prevent the product from returning to the crystallizer. In addition, for collection of Product 2, an assistance from a small path with the diaphragm pump is important to collect all the products effectively. Lastly, the flushing process is performed to clean the crystallizer. V-2 and V-5 are opened for 5 minutes to enable the water from Tank 2 to circulate in the crystallizer in order to rinse the crystallizer to remove all the residues from the process. Proper rinsing is one of the important steps to ensure high quality production. Finally, V-7 is opened to allow disposal of rinsed water. During the whole process, P-1 is kept turned on except during the ice melting process. Then, shut down procedure will be performed by turning off all of the equipments involved. Volume and concentration of both Product 1 and Product 2 are measured for further analysis. Figure 6 shows the camera screenshots images inside the crystallizer for all the process sequences.

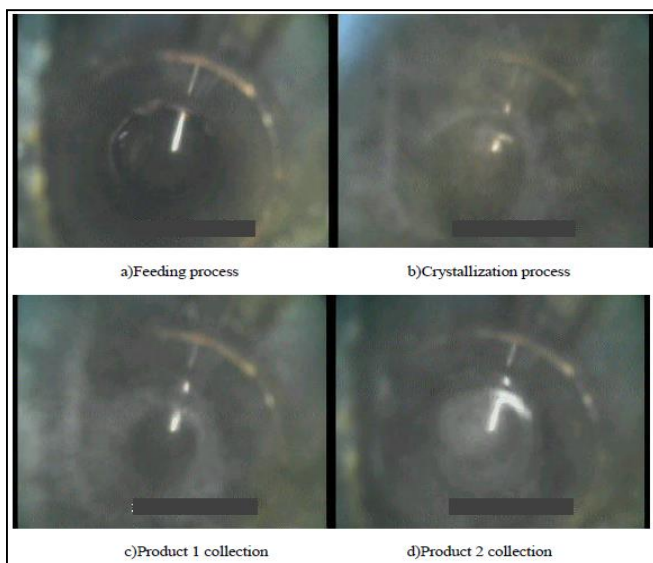

Figure 6 Camera screenshots images

As shown in Figure 6(a), for feeding process the target solution is pumped and circulated in the crystallizer and followed with the crystallization process in Figure 6(b). During this process, it can be seen that the ice crystal is formed layer by layer on the wall of the crystallizer until the space for solution flow gets smaller. After the designated time is reached, the concentrated solution is collected and the ice layer can be seen more clearly (Figure 6(c)). Finally, the ice layer is thawed and collected for further analysis as shown in Figure 6(d). Figure 7 shows the graph of the designed sequence and actual sequence for PFC process.

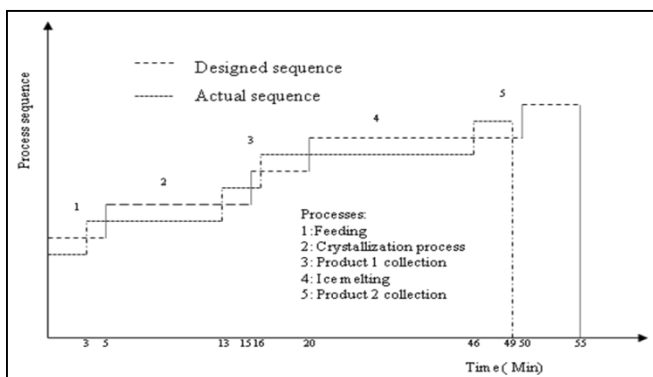

Figure 7 Designed sequence and actual sequence graph

It can be seen from the graph that the time delay proposed for feeding process is initially 5 minutes from the designed sequence. But in the actual sequence, it can be reduced to 3 minutes based on the observation that the target solution already fulfills the crystallizer and the pipelines. After the crystallization process has finished at the designated time (10 minutes), collection of Product 1 is initially set for 5 minutes but according to the observations, it is sufficient to set the time for 3 minutes only. This is because of the assistance from the small path and the fact that the heater tape works well and efficient. The same situation is observed during collection of Product 2. Thus, time for actual sequence for collection of Product 2 can be reduced to 3 minutes as well. Time

taken to increase the coolant temperature for ice melting was set according to the designed sequence which is 30 minutes.

4.0 CONCLUSION

This paper introduces a timeline for process sequence for PFC process since the application of the process in industrial scale is not covered yet. The sequence is developed based on step needed to carry out in the PFC process to ensure safe operation and improve overall performance of the system. Process sequence development for automated PFC system could bring the design to the next level and used as a starting point for commercialization purpose.

Acknowledgement

All individuals who provide ideas and innovation as well as participate in this research are much appreciated. The authors also acknowledge the financial support from Universiti Teknologi Malaysia, Malaysia.

References

- [1] Nakagawa, K., S. Maebashi, and K. Maeda. 2010. Freeze-Thawing As a Path to Concentrate Aqueous Solution. *Sep. Purif. Technol.* 73: 403–408.
- [2] Deshpande, S. S., H.R. Bolin, and D. K. Salunke. 1982. Freeze Concentration of Fruit Juice. *Food Technol.* 39: 68–82.
- [3] Petzold, G., K. Niranjan, and J. M. Aguiler. 2013. Vacuum-Assisted Freeze Concentration of Sucrose Solutions. *J. Food Eng.* 115: 357–361.
- [4] Rolf, H. 1980. Concentration of Impurities by Progressive Freezing. *Water Res.* 14: 575–580.
- [5] Glen, J. W. 1974. The Physics of Ice. CRREL Monogr.
- [6] Morison, K. R., and R.W. Hartel. 2006. Evaporation and Freeze Concentration. *Handbook of Food Engineering.* 496–550.
- [7] Liu, L., O. Miyawaki, and K. Nakamura. 1997. Progressive Freeze-Concentration of Model Liquid Food. *Food Sci. Technol. Int.* 3: 348–352.
- [8] Habib, B., and M. Farid. 2007. Freeze Concentration of Milk and Saline Solutions in a Liquid–Solid Fluidized Bed: Part I. Experimental. *Chem. Eng. Process: Process Intensification.* 46: 1400–1411.
- [9] Nakagawa, K., S. Maebashi, and K. Maeda. 2010. Freeze Thawing As a Path to Concentrate Aqueous Solution. *Sep. Purif. Technol.* 73: 403–408.
- [10] Sánchez, J., Y. Ruiz, J. M. Auleda, E. Hernández, and M. Raventós. 2009. Review: Freeze Concentration in the Fruit Juices Industry. *Food Sci. Technol. Int.* 15: 303–315.
- [11] Aider, M., and D. de Halleux. 2009. Cryoconcentration Technology in the Bio-Food Industry: Principles and Applications. *Food Sci. Technol.* 42: 679–685.
- [12] Matthews, J. S., and N. D. Coggeshall. 1959. Concentration of Impurities from Organic Compounds by Progressive Freezing. *Anal. Chem.* 31: 1124–1125.
- [13] Sánchez, J., E. Hernández, J. M. Auleda, and M. Raventós. 2011. Freeze Concentration of Whey in a Falling-Film Based Pilot Plant: Process and Characterization. *J. Food Eng.* 103: 147–155.
- [14] Miyawaki, O., L. Liu, and K. Nakamura. 2011. Effective Partition Constant of Solute between Ice and Liquid Phases in Progressive Freeze Concentration. *J. Food Sci.* 63: 1–3.
- [15] Chen, P., D. C. Xiao, and K. W. Free. 1998. Solute Inclusion in Ice Formed From Sucrose Solutions on Aa Sub-Cooled Surface: An Experimental Study. *J. Food Eng.* 38: 1–13.
- [16] Shirai, Y., M. Wakisaka, O. Miyawaki, and S. Sakashita. 1998. Conditions of Producing an Ice Layer With High Purity for Freeze Wastewater Treatment. *J. Food Eng.* 38: 297–308.
- [17] Rodriguez, M., S. Luque, J. R. Alvarez, and J. Coca. 2000. A Comparative Study of Reverse Osmosis and Freeze Concentration for the Removal of Valeric Acid from Wastewaters. *Desalination.* 127: 1–11.
- [18] Lorain, O., P. Thiebaud, E. Badorc, and Y. Aurelle. 2001. Potential of Freezing in Wastewater Treatment: Soluble Pollutant Applications. *Water Res.* 35: 541–547.
- [19] Wakisaka, M., Y. Shirai, and S. Sakashita. 2001. Ice Crystallization in a Pilot-Scale Freeze Wastewater Treatment System. *Chem. Eng. Process: Process Intensification.* 40: 201–208.

- [20] Ramos, F. A., J. L. Delgado, E. Bautista, A. L. Morales, and C. Duque. 2005. Changes in Volatiles with the Application of Progressive Freeze-Concentration to Andes Berry (*Rubus Glaucus Benth*). *J. Food Eng.* 69: 291–297.
- [21] Miyawaki, O., L. Liu, Y. Shirai, S. Sakashita, and K. Kagitani. 2005. Tubular Ice System for Scale-Up of Progressive Freeze-Concentration. *J. Food Eng.* 69: 107–113.
- [22] Raventós, M., E. Hernández, J. Auleda, and A. Ibarz. 2007. Concentration of Aqueous Sugar Solutions in a Multi-Plate Cryoconcentrator. *J. Food Eng.* 79: 577–585.
- [23] Rich, A., Y. Mandri, D. Mangin, A. Rivoire, S. Abderafi, and C. Bebon. 2012. Sea Water Desalination by Dynamic Layer Melt Crystallization: Parametric Study of the Freezing and Sweating Steps. *J. Cryst. Growth.* 342: 110–116.
- [24] Auleda, J. M., M. Raventós, and E. Hernández. 2011. Calculation Method for Designing a Multi-Plate Freeze-Concentrator for Concentration of Fruit Juices. *J. Food Eng.* 107: 27–35.
- [25] Englezos, P. 1992. *The Freeze Concentration Process and Its Applications*. University of British Columbia, Vancouver, British, Columbia.