

Design of a New Low Cost ROV Vehicle

Yasser M. Ahmed^{a,b}, Omar Yaakob^{a*}, Bong K. Sun^b

^aMarine Technology Centre, Universiti Teknologi Malaysia, 81310 UTM Johor Bahru, Johor, Malaysia

^bFaculty of Mechanical Engineering, Universiti Teknologi Malaysia, 81310 UTM Johor Bahru, Johor, Malaysia

*Corresponding author: Omar@fkm.utm.my

Article history

Received :20 February 2014

Received in revised form :

2 March 2014

Accepted :22 May 2014

Graphical abstract

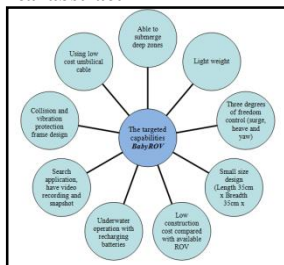

Abstract

Remotely operated underwater vehicles which are also known as ROVs are a type of underwater robot vehicle which is widely used in the offshore industry or other applications. The main purpose of this type of tethered underwater mobile robots are to supersede human to work at hard-to-access or jeopardizing underwater region to do certain specific tasks like to survey a site, search for an item or person that has tremendous value. The remote control of ROV is usually carried out through copper or fiber optic cables which are known as umbilical cables. In this research work a low cost ROV unit has been designed and constructed at Universiti Teknologi Malaysia (UTM). The ROV was constructed by low cost material like commercial grade polyvinyl chloride (PVC) pipes. The low cost ROV is equipped with a network camera and manoeuvred by three motors through 12 volts battery power supply. The ROV is controlled by joystick controller through network cable and is able to submerge up to 20 meters into water to perform underwater observation operation.

Keywords: ROV; drag force; underwater operation

© 2014 Penerbit UTM Press. All rights reserved.

1.0 INTRODUCTION

ROV is classified as a crewless submersible vehicle that is tethered to a vessel on the surface by a cable; it has a video camera, lights, thrusters that generally provide three dimensional maneuverability, depth sensors, and wide array of manipulative and acoustic devices, as well as special instrumentation to perform a variety of work tasks [1]. In other words, an underwater remotely operated vehicle (ROV) also can be called as a mobile robot designed for aquatic work environments. Remote control is usually carried out through copper or fiber optic cables, or called umbilical cable. The ROV operation is fully controlled by a human operator who sits in a shore-based station, boat or submarine bubble while watching a display that shows what the robot sees. The operator can manoeuvre with the robot to avoid some obstacles or for any other purpose. Sophisticated underwater ROVs incorporate tele-presence to give the operator a sense of being in the place of the machine [2].

ROV operations are usually simpler and safer than submarine or SCUBA diving and can be deployed for longer periods of time. They can also be used in situations where it would be hazardous or expensive to send a submarine or divers, such as clearing minefields or during bad weather. The disadvantages of using a ROV include the fact that the human presence is lost, making visual surveys and evaluations more difficult, and the lack of freedom from the surface due to the ROV's umbilical connection [3].

The first ROV developers still remain unknown; however, there were two who are believed to be the pioneers in ROV

development process. The PUV (Programmed Underwater Vehicle) was a torpedo developed by Luppis-Whitehead Automobile in Austria in 1864, however, the first tethered ROV, named POODLE, was developed by Dimitri Rebikoff in 1954 [4]. The United States Navy was an initiator who advanced the technology to an operational state in its quest to develop some kind of underwater robots to recover underwater weapons lost during sea tests. ROVs became more famous when US Navy CURV (Cable Controlled Underwater Recovery Vehicle) systems recovered an atomic bomb lost off Palomares Spain in an aircraft accident in 1966, and then saved the pilots of a sunken submersible off Cork, Ireland, the Pisces in 1973, with only minutes of air remaining [4].

ROVs became essential in the 1980s when much of the new offshore development exceeded the reach of human divers. During the mid of 1980s the marine ROV industry suffered from serious stagnation in technological development caused in part by a drop in the price of oil and a global economic recession. Since then, technological development in the ROV industry has accelerated and today ROVs perform numerous tasks in many fields. Their tasks range from simple inspection of subsea structures, pipeline and platforms to connecting pipelines and placing underwater manifolds. They are used extensively both in the initial construction of a sub-sea development and the subsequent repair and maintenance. Submersible ROVs have been used to locate many historic shipwrecks, including that of the RMS Titanic, the Bismarck, USS Yorktown, and SS Central America. In some cases, such as the SS Central America, ROVs

have been used to recover material from the sea floor and bring it to the surface [5].

The demand of the low cost ROV increases recently due to more companies, professional people, university students, public organizations, police and military or ROVs admirers wishing to have their own ROV. They may use the ROV as a specific research tool, special operation device or personal hobby robot. The main objective of this research work was to design and build a low cost ROV which will be used to submerge into hard-to-access and dangerous underwater regions in Malaysian seas for the purposes of research and survey.

2.0 CONCEPTUAL DESIGN FOR THE NEW ROV

The new low cost ROV for this research work was given a name of BabyROV. Before the construction of BabyROV, some important specifications of BabyROV have been identified as shown in Figure 1. Based on the specifications of the ROV, a conceptual design has been made for BabyROV using SolidWorks program [6] (Figure 2(a)). The shape of the conceptual design for BabyROV was a bullet type, which had the advantage of less drag coefficient during underwater operation. Besides that, collision and vibration protection frame was designed to surround the main body of BabyROV; this will reduce the possibility of damage on ROV structures during high current flow operation or in case of accidents. The camera housing was located in front of main body, and protected by protective frame. Furthermore, in order to prevent camera visual's obstacle problem, the protective frame was design only cover the top and bottom part of camera housing (Figure 2(b)).

The conceptual design of BabyROV is able to perform six degrees of freedom motions during underwater operation. There are three horizontal thrusters installed at aft of BabyROV, the function of these three thrusters is to enable the ROV from moving in surge, pitching and yawing directions. For battery saving mode of operation, only two thrusters can work together to maintain the surge direction of the vehicle. Furthermore, to prevent the effect of the thrust produce by aft thrusters on the hull of the ROV unit, two nozzles were installed for aft thrusters. The unit is provided with two vertical thrusters to allow BabyROV to move in heave and rolling direction. The sway thruster in the ROV is used to perform sway motion.

For the reason of brighter, clearer and wider range of lighting coverage required during underwater operation, the lighting housing was design to place on top of camera housing. There were two lighting housing for light bulbs, both were able to adjust their position by the aid of servo motors.

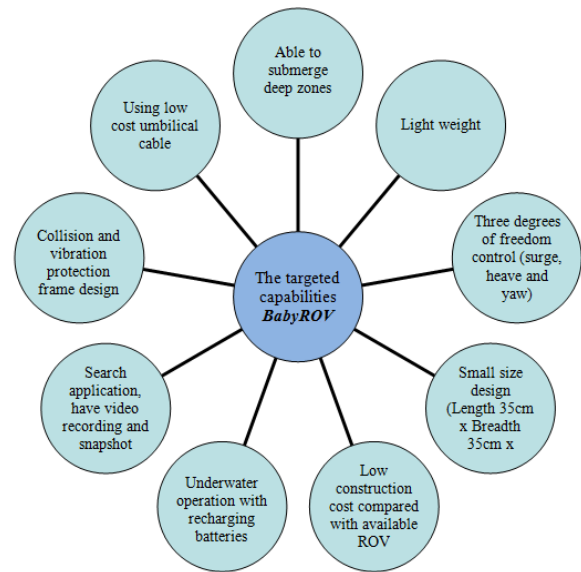

Figure 1 BabyROV main specifications

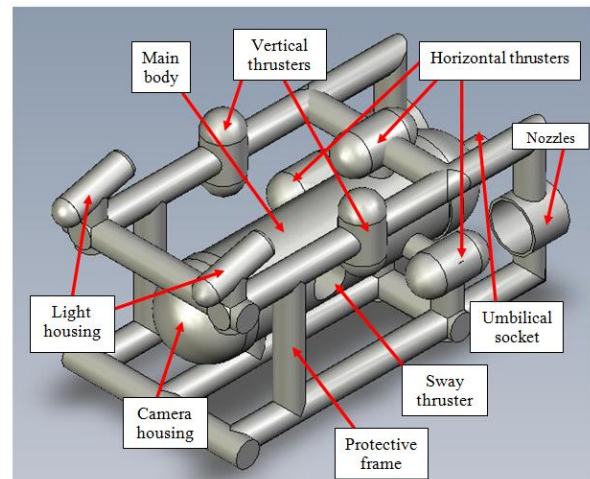

Figure 2(a) General description of BabyROV conceptual design

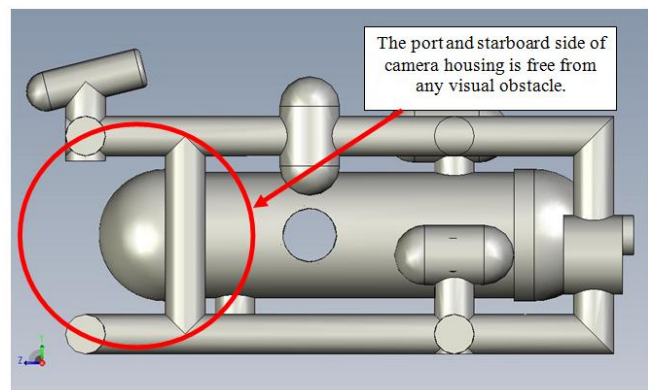

Figure 2(b) camera housing in BabyROV conceptual design

The weight estimation for BabyROV was found to be approximately 8.5 kg (Table 1), which ensure that the power of the thrusters to the weight ratio for the ROV is high.

Table 1 Estimated weight for BabyROV body without umbilical cable and joystick controller

No	Accessories	Units weight (Kg)	Units	Total weight (Kg)
1	Thrusters (DC motors/bilge pump)	0.28	6	1.68
2	RC boat Propellers (plastic made)	0.06	6	0.36
3	Propeller shaft adapter	0.04	6	0.24
4	Camera	0.30	1	0.30
5	Camera cover glass	0.40	1	0.40
6	Light with battery	0.40	2	0.80
7	PVC pipe + Circuits Housing	2.00	1	2.00
8	Pressure sensor	0.05	1	0.05
9	Temperature Sensor	0.03	1	0.03
10	Electronic circuits	0.30	1	0.30
11	Battery set	0.65	2	1.30
12	Servo motor	0.47	2	0.94
13	Miscellaneous	0.10	1	0.10
		Total		8.50

In order to estimate the drag force (F_d) of BabyROV the following assumptions were made:

- The dimensions of BabyROV are L (length) = 35 cm x B (breadth) = 35 cm x H (height) = 25 cm.
- The medium of BabyROV operation is in sea water.
- The drag force is calculated at the maximum speed of BabyROV which is 1 knot (0.51444 m/s).
- The shape of BabyROV is bullet type, which has a drag coefficient of approximately 0.6.
- The type of umbilical cable is hair faired type, which has a diameter of 1.0 cm, drag coefficient of 0.5 and umbilical length of 35 m.
- Due to the drag equation did not include the added mass effect, 10 percent of correction will be added into final result.

Finally, the drag force of BabyROV has been calculated using the following equation:

$$F_d = \left[\frac{1}{2} \rho V^2 C_d A \right]_{BabyROV} + \left[\frac{1}{2} \rho V^2 C_d A \right]_{Umbilical} \quad (1)$$

where, ρ is fluid density, V unit velocity, C_d ROV drag coefficient and A frontal area of BabyROV. The values of the different terms in the previous equation are defined in the equation below.

$$F_d = \frac{1}{2} (1025) \left[(0.51444^2) (0.8) (0.1225) \right]_{BabyROV} + \left[(0.51444^2) (0.5) (0.5498) \right]_{Umbilical} \\ = 50.58 \text{ N}$$

Without ignoring the effect of added mass as mentioned before, a marginal correction is added to the final result as follows:

$$F_d = 50.58 + 10\% * (50.58) \\ = 55.638 \text{ N}$$

The power required (P_d) for BabyROV was calculated from

$$P_d = F_d * V = 55.638 * 0.51444 = 28.622 \text{ Watt} \quad (2)$$

3.0 ROV CONSTRUCTION AND RESULTS

Once the final conceptual design of the BabyROV was finished the construction process started directly. Almost 95% of the ROV material were using PVC pipe and purchased from hardware shop. The material list and total expenditure for BabyROV is shown in Table 2 below.

Table 2 Material and total expenditure for BabyROV

Category	Items	Quantity	Unit price (RM)	Total Amount (RM)
Main Body	PVC Ø90mm	1	10	10
Protective Frame	PVC pipe and joints	-	-	100
Thrusters	Car Vacuum cleaners	3	20	60
	PE	2m	5	10
	Aluminium bar	1m	15	15
	Drill bits	2	10	20
	Spring	2	6	12
Paint, Join and Seal	Paints	5	6	30
	Thinner	2	5	10
	PVC Pipe Glue	2	5	10
	Super Glue	4	3.5	14
	Epoxy	8	10	80
	Silicon	1	10	10
	Cable tight	50	0.2	10
Lighting	LED Torch Light	1	30	30
	Bulb Torch Light	2	10	20
Camera and camera housing	IP CMOS Cam	1	250	250
	Armour Dome	1	80	80
	LAN Cable	20m+20m	1	40
	LAN Socket	2	6	12
	Servo Motor	1	50	50
Electronic	Main Circuit	1	700	700
	SKPS	1	99	99
	Joystick	1	20	20
	USB ICSP PIC Programmer	1	50	50
	Lithium Polymer Battery	2	180	360
TOTAL				2102

The mechanical parts of BabyROV can be divided into the following categories: main body, protective frame, propulsion units, lighting units and camera housing. The mechanical parts construction required manual and custom handmade. The process of mechanical parts construction is shown in the (Figure 3). Almost 95 percent of the materials were using PVC pipes to reduce the construction cost of the ROV.

The camera housing was made in this research work by using armour dome, which is able to sustain high pressure from water. For protective frame construction for the ROV and its camera, PVC pipe joints like Tee-Joint, End cap, PVC pipe socket, Sweep Bend, Elbo etc. were used. Lighting units made by two type of lighting bulb, there are LED torch light and normal yellow bulb torch light.

The underwater circuit for BabyROV board (Figure 4) was built based on the schematic given by Cytron Technologies Sdn. Bhd. [7]. The main function of this circuit board was to control the BabyROV system, and it was stored inside the main body of BabyROV. The power supply to the main circuit and camera circuit was 12 Volt by Lithium Polymer battery. BabyROV uses IP CMOS Cam or network camera which utilized LAN cable to transmit visual data to the computer (Figure 5).

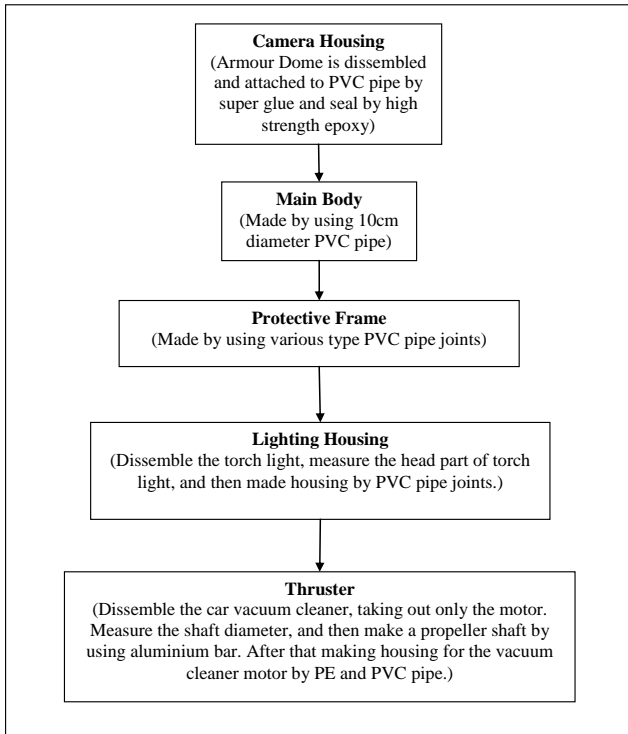

Figure 3 Mechanical parts construction procedure for BabyROV

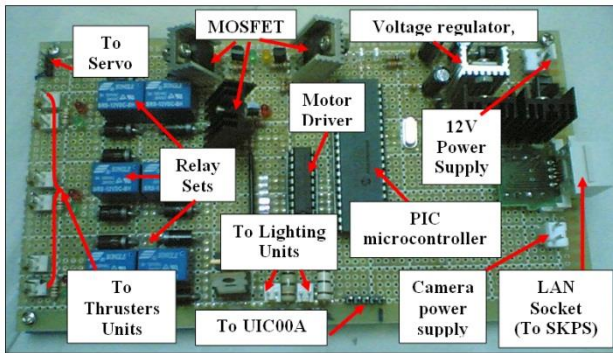

Figure 4 General description of BabyROV main circuit

The land circuit is a circuit which is placed on the shore side in order to control the underwater circuit. For BabyROV the most important circuit on shore is SKPS which is a special communication circuit design to communicate between two devices or circuits through a PlayStation2 (PS2) controller by Universal Asynchronous Receiver/Transmitter(UART) protocol method [8]. A UART protocol was used for the communication between underwater and land control circuits in BabyROV (Figures 6(a) and 6(b)) show the BabyROV land control circuit which use SKPS and the configurations of PS2 controller.

The control system of BabyROV is mainly depending on the communication between underwater and land control circuits. However this problem was solved by using UART protocol (Universal Asynchronous Receiver/Transmitter), which is a type of "asynchronous receiver/transmitter" and a piece of computer hardware that translates data between parallel and serial forms. UART is usually an individual (or part of an) integrated circuit used for serial communications over a computer or peripheral device serial port. With UART protocol, there will not be a problem for 20 meters signals transmission from underwater to land control circuit.

Another important control module for motor speed control is PWM (Pulse Width Modulation) module [9], or called Pulse-width modulation of a signal or power source involves the modulation of its duty cycle, to either convey information over a communications channel or control the amount of power sent to a unit. The speed of BabyROV thrusters were controlled by PWM module through PIC microcontroller. The detailed description of BabyROV control system schematic is presented in Figure 7.

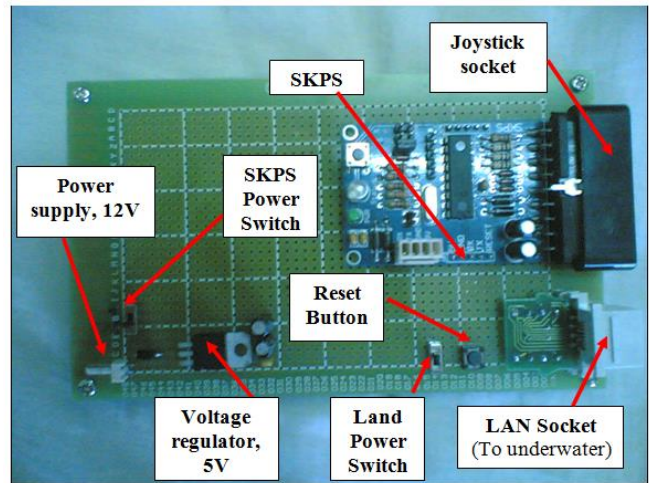

Figure 6(a) BabyROV land control circuit

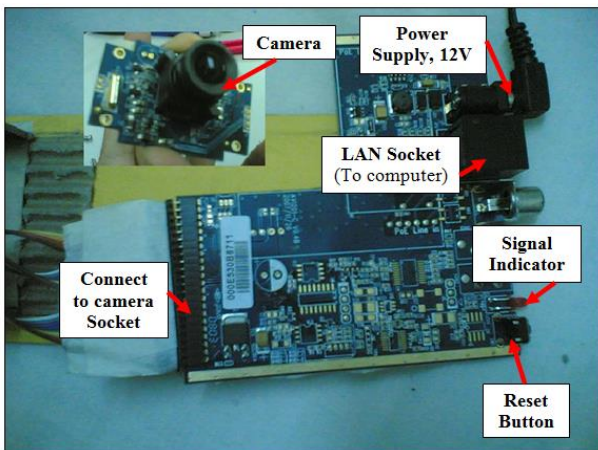

Figure 5 BabyROV IP CMOS Camera circuit

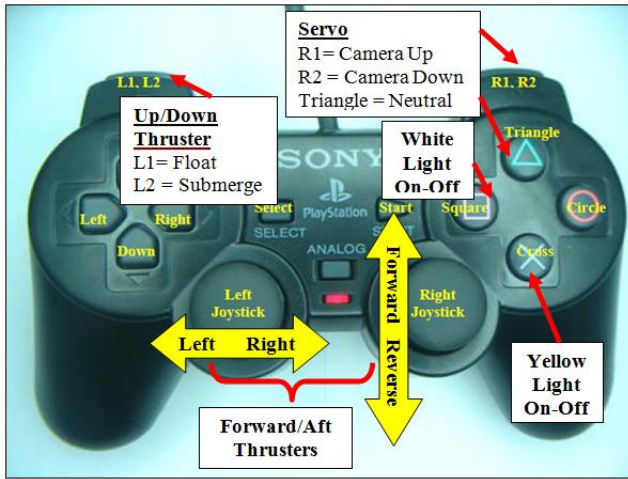

Figure 6(b) BabyROVSony playstation joystick controller manual

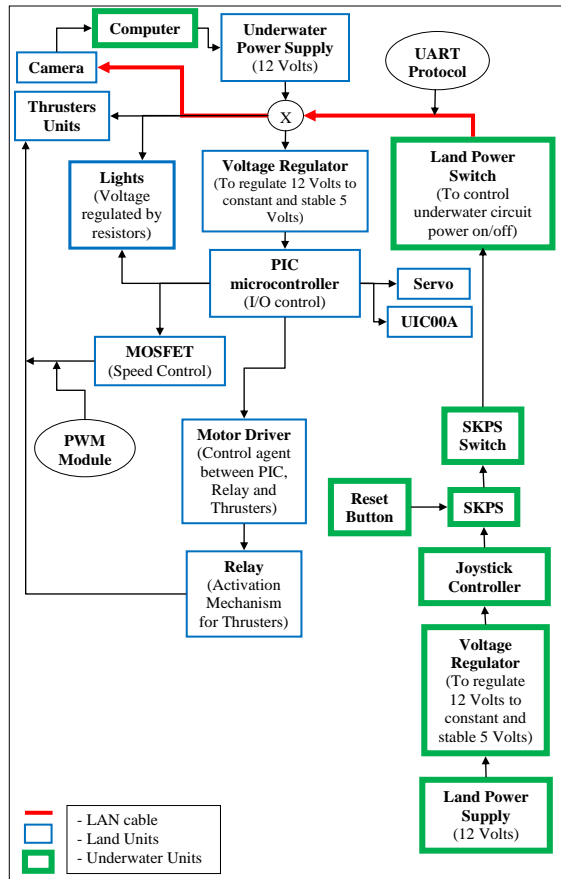

Figure 7 Schematic flowcharts for BabyROV control system

After finishing the physical part of BabyROV, a program was written to the ROV PIC microcontroller with C language through Microchip MPLAB IDE v8.10 software [10], which is a software program that runs on a PC to develop applications for Microchip microcontrollers. It is called an Integrated Development Environment, or IDE, because it provides a single integrated “environment” to develop code for embedded microcontrollers.

4.0 UNDERWATER TESTS FOR THE ROV

To ensure the stability of submerged vehicles, it is important to maintain the centre of gravity below the centre of buoyancy. Also, to enable it to easily submerged and surface, the vehicle must be neutrally buoyant. These two characteristics are incorporated in BabyROV making it. Ballast weights of 2.2 kg enabled it to submerge underwater and perform well in forward and reverse motions. Figure 8 shows the stability testing of BabyROV.

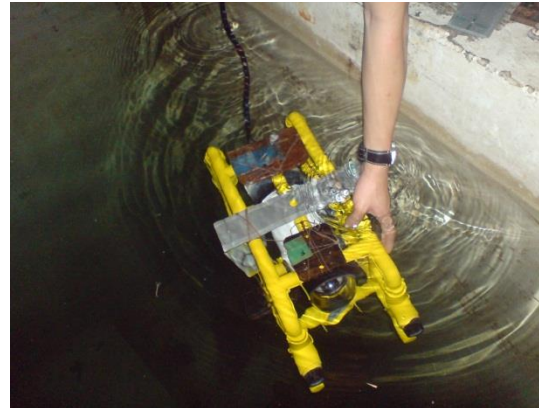

Figure 8 Testing on BabyROV

BabyROV is able to submerge into 2.5 meter (Figure 9) below the water free surface in UTM towing tank without any leaking problem in ROV main body and protective frame. The maximum water depth of UTM towing tank is 2.5 meter, but according to the design calculations and the strength of BabyROV structural members, it is able to submerge up to 20 m below water surface. Finally, the tests showed that it is better if using submerged motors for the ROV in the future, which can operate well in the underwater environment.

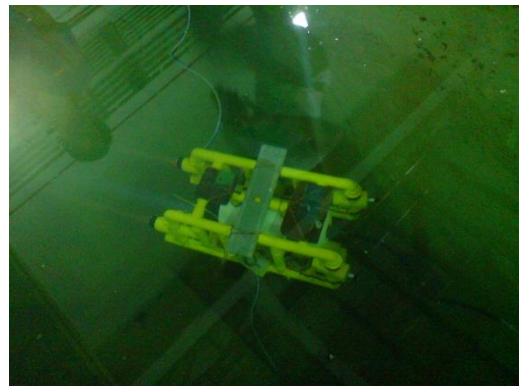

Figure 9 BabyROV submerged to 2.5 m in UTM towing tank

From the underwater trial tests, BabyROV was able to perform all maneuvering tests (Figure 10) like moving forward, reverse, float and submerge. The problems in these maneuvering tests were large turning radius and slow reverse speed. The distance between the two aft thrusters quite are close to each other, resulting in a large turning radius. However this is not a very serious problem and not critical to the overall of BabyROV performance. The main reason on slow reverse speed is the high

speed boat propellers installed was, which are perfect for fast forward purpose but not suitable for use in reverse condition. With the power supply by 12 V Lithium Polymer battery (Figure 11), BabyROV was able to operate underwater for approximately 40 minutes. Both underwater and land control circuits each have one battery supply. BabyROV was installed with one IP CMOS Network Cam. During the underwater trial, BabyROV's camera was able to capture and take snapshots with adjusting position by servomotor.

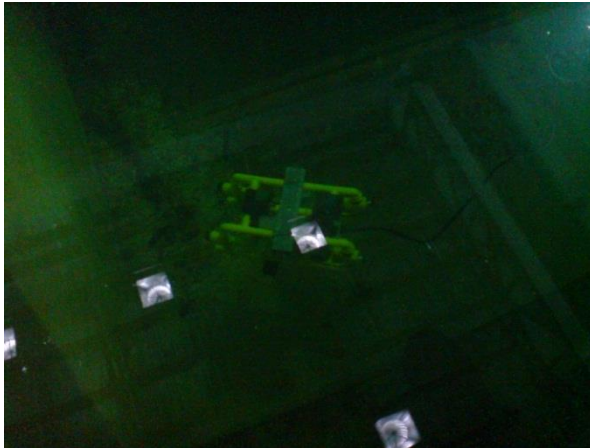

Figure 10 BabyROV in maneuvering tests



Figure 11 ROV 12 volts 220 mAh Lithium Polymer battery

5.0 CONCLUSION

In this research project a low cost ROV has been designed and constructed to perform different underwater tasks up to 20 m. Low cost material (PVC pipes) was mainly used for constructing the body of BabyROV to reduce the cost. Great care and attention were given to the construction process to make sure that the final. The different tests that have been conducted for BabyROV showed its good ability for moving and maneuvering underwater in UTM towing tank during the various conditions. However, BabyROV need more modifications such as a use of more efficient submersible motors for the ROV thrusters and utilize of more convenient water propellers.

Acknowledgement

The authors would like to express our sincere gratitude to Universiti Teknologi Malaysia (UTM) who assist and provide in the data compilation for this publication.

References

- [1] Azis F. A., Aras M. S., Rashid M. Z., Othman M. N., Abdullah S. S. 2012. Problem Identification for Underwater Remotely Operated Vehicle (ROV): A Case Study. *Procedia Engineering*, 41: 554–560.
- [2] Robert D. C., Robert L. W. 2007. *The ROV Manual: A User Guide for Observation-Class Remotely Operated Vehicles*. First edition. Elsevier Ltd. Oxford UK.
- [3] Jarrett S. S., Dave W., Tom T. 2007. Deep-Sea ROV Cable. *Proceedings of the 56th International Wire & Cable Symposium*. 401–408.
- [4] Remotely Operated Vehicle Committee of the Marine Technology Society, History of the ROV Committee, available at: <http://www.rov.org/history.cfm> (accessed in 22nd of August 2013).
- [5] Remotely operated underwater vehicle, Wikipedia the Free Encyclopedia web site, available at: http://en.wikipedia.org/wiki/Remotely_operated_underwater_vehicle (accessed in 22nd of August 2013).
- [6] Solid Works web site available at: <http://www.solidworks.com/> (accessed in 23rd of August 2013).
- [7] Cytron Technologies web site available at: <http://www.cytron.com.my/> (accessed in 23rd of August 2013).
- [8] Hu Z., Zhang J., Luo X. 2007. A Novel Design of Efficient Multi-channel UART Controller Based on FPGA. *Chinese Journal of Aeronautics*, 20: 66–74.
- [9] Chen G., Kang J., Zhao J. 2013. Numeric Analysis and Simulation of Space Vector Pulse Width Modulation. *Advances in Engineering Software*, 65: 60–65.
- [10] Microchip web site available at: <http://www.microchip.com> (accessed in 23rd of August 2013).