

## FIRE-FLAME IMAGING USING ELECTRICAL CAPACITANCE TOMOGRAPHY

RUZAIRI ABDUL RAHIM<sup>1</sup>, CHAN KOK SEONG<sup>2</sup>, SALLEHUDIN IBRAHIM<sup>3</sup>,  
SHAHARUM SULAIMAN<sup>4</sup>, MOHAMAD SHUKRI ABDUL MANAF<sup>5</sup>

**Abstract.** The specific characteristic of tomographic measurement is its proven ability to interrogate the dynamic state of a process condition within a unit operation such as a mixing vessel or conveyor without interfering with the process itself. This is achieved using non-invasive sensors along a cross-sectional boundary of the process equipment. Electrical Capacitance Tomography (ECT) is a non-intrusive technique for obtaining information about the distribution of the contents of closed pipes by measuring variations in the dielectric permittivity of the material within the electrodes sensing region. An 8 electrode ECT sensor system with a graphical user interfacing (GUI) software programming has been developed by using Microsoft Visual Basic 6.0. This system can be used to investigate the distribution of fire flame inside the vessel. Data from the hardware system can be acquired directly to computer through a microcontroller control unit to provide the cross sectional image of the fire flame. Image reconstruction algorithm used in this project is the conventional, but effective Linear Back Projection (LBP).

*Key words:* Electrical Capacitance Tomography, fire flame, Linear Back Projection, non-intrusive, Visual Basic

**Abstrak.** Ciri-ciri sifat pengukuran tomografik yang khusus telah terbukti dengan keupayaannya untuk memisit keadaan dinamik suatu proses dalam satu unit pengoperasian seperti dalam kebuk atau alat pengangkut tanpa memberi sebarang gangguan kepada proses tersebut. Proses Tomografi Kapasitan (*Electrical Capacitance Tomography*–ECT) merupakan teknik tidak intrusif untuk mengetahui taburan kandungan dalam paip dengan mengkaji perubahan ketelusan dielektrik bagi bahan yang terkandung dalam paip. Satu pengesan ECT 8 elektrod dengan pengaturcaraannya dalam Microsoft Visual Basic 6.0 telah dibina untuk menunjukkan paparan pengguna. Sistem ini berupaya mengetahui pembahagian api yang terbakar dalam sesuatu perkakas. Data daripada sistem perkakas akan diperolehi melalui satu unit pengawal dan dimasukkan dalam komputer untuk mendapatkan gambaran keratan rentas pembakaran api. Algoritma pembinaan semula imej (*Image Reconstruction Algorithm*) yang digunakan dalam projek ini adalah Unjuran Belakang Linear (*Linear Back Projection* LBP) yang konvensional tetapi efektif.

*Kata kunci:* Proses Tomografi Kapasitan, pembahagian api yang terbakar, Unjuran Belakang Linear, tidak intrusif, Visual Basic

---

<sup>1-5</sup>Control & Instrumentation Engineering Department, Faculty of Electrical Engineering, Universiti Teknologi Malaysia, 81310 Skudai, Johor Bahru, MALAYSIA. Email: ruzairi@fke.utm.my

## 1.0 INTRODUCTION

Process tomography has been around for a reasonable amount of time now. The development of tomographic instrumentation, started in the 1950's, and has led to the widespread availability of body scanners which is part of modern medicine nowadays [1]. Process tomography evolved essentially during the mid-1980. A number of imaging equipment for processes was described in the 1970's, but generally this involved using ionization in x-rays, etc. In the mid-1980's, researches had been started from which, led to the present work on process tomography systems.

Generally, Process Tomography is a technique used to investigate the internal behaviors of flowing materials in a pipeline [2]. It used to delineate the internal composition of pipes or mixing vessels. There are many different types of tomographic methods used to obtain different readings. For example, one of these types would be sensors (mainly electrodes) mounted around a cylindrical vessel or object to obtain different measurement readings through the device under test [2].

There is various kind of techniques or methods of tomographic measurement used in industrial processes. Each method has its particular advantages and disadvantages. Various forms of tomography are being investigated around the world, of which includes: Electrical Resistance Tomography, Electrical Capacitance Tomography, Electrical Impedance Tomography, Optical Sensor Tomography and Ultrasound or Ultrasonic Tomography.

### 1.1 Electrical Resistance Tomography (ERT)

The fundamental aim of electrical resistance tomography is to establish the electrical conductivity from measurements of voltage around the periphery of a vessel [1]. It is mainly used for measurement of gas-liquid and other mixed liquids. ERT involves the acquisition of measurement signals.

Measurement of electrical resistance via four probes is widely used in a range of applications. For example, resistance tomography measurements with circular array electrodes were conducted in the biomedical and the industrial fields. This is achieved by simply placing four equally-spaced electrodes around a body, which are used for measurement purposes [1]

### 1.2 Electrical Capacitance Tomography (ECT)

Electrical capacitance tomography is known as the other extreme of electrical impedance tomography, whereby it is the measurement of the dielectric constant. This was one of the techniques which were first developed for process tomography [3]. It is low cost, high speed, robust and non-intrusive. As shown

in the equation below, if the area of the plate is known, as well as the distance between them, so effectively by measuring the capacitance; we are effectively measuring the dielectric constant.

$$C = \frac{\epsilon A}{d} \quad (1)$$

$A$  - Area of plate

$d$  - Distance between plates

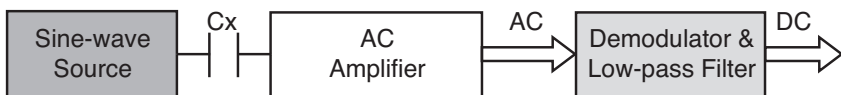
$\epsilon$  - Dielectric constant of material between plates

There are two types of measurement circuits suitable for ECT. They are the charge/discharge circuit and the AC based circuit, due to their immunity to stray capacitance.

As shown by Yang [4-5], the main difference between these two types of circuits lies in the positions of the demodulators. In a charge / discharge circuit, as shown in block diagram form in Figure 1, the demodulator precedes any of the signal amplification. For the AC-based circuit in Figure 2, the AC signal from the measured capacitance is amplified and thereafter demodulated [4].



**Figure 1** Block diagram of a charge / discharge circuit



**Figure 2** Block diagram of an AC-based circuit

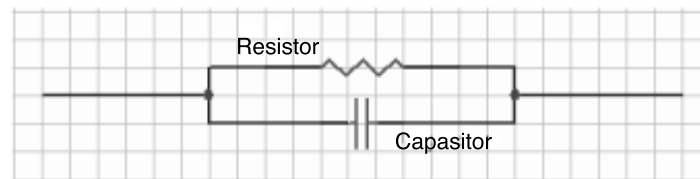
The sensors are in the form of electrodes which are symmetrically mounted on the outside of an insulating pipe or vessel. The sensing electronics then takes measurements for all possible combination pairs of electrodes. Specifically for capacitance tomography measurements, the surface of the electrode needs to be sufficiently large to provide sufficient signal [5].

### 1.3 Electrical Impedance Tomography (EIT)

Electrical impedance tomography (also called applied potential tomography) is a non-invasive inverse method which is able to determine the electrical conductivity of a medium by making voltage and current measurements at the boundaries of the object. This special technique is widely used in the medical and the industrial field [1].

In industry, it is mainly used to recreate images of the contents within a pipe, vessel or object. This helps the operator to visualize the internal behaviour of industrial processes. There are various applications whereby impedance tomography is used in the medical imaging and measurement purposes[2].

Electrical impedance tomography (EIT) involves the measurement of changes in both the resistance, and the reactive components from the multielectrode sensor of the system or material [1]. An electrical model of a typical impedance system is shown in Figure 3. This alteration of impedance is due to the type of material under investigation. This type of measurement is made possible due to the different electrical resistivities of the various types of materials.



**Figure 3** Diagram showing the electrical model of EIT

To measure resistivity or impedivity, a current must flow in the tissue and the corresponding voltages must be measured [1]. This applied current is referred to as excitation current. To obtain images with good spatial resolution, a number of measurements should be taken. From the results obtained, an image reconstruction technique is developed to generate the tomographic image.

### 1.4 Optical Sensor Tomography

Optical tomography involves projecting a beam of light through a medium from one boundary point and detecting the level of light received at another boundary point [6]. This optical system can be designed by using a transmitter-receiver pair such as light emitting diode (LED) and photo detector [7]. In general, infra-red and visible lights are used as transmitter in optical sensor.

The main function of LED is to generate a light in the form of collimated beam that will propagate through the material (transparent), attenuated and received by sensing photo detectors. The multiplexed sensor generates analogue voltage signal (based on the light signal received by sensing photo detector) shows the amount of attenuation in the path of the beam caused by the flow regime. Usually, several groups of transmitter and receiver pairs are employed to obtain image in better resolution and minimizing the aliasing that occurs when two particles intercept the same view.

The major problems associated to optical sensors are in obtaining better resolution caused by limitation of space for sensor placement whereby sensor cannot be arranged too close to each other to avoid reflection [8]. To improve the resolution, smaller optical devices (e.g. optical fibre) should be used.

### 1.5 Ultrasound or Ultrasonic Tomography

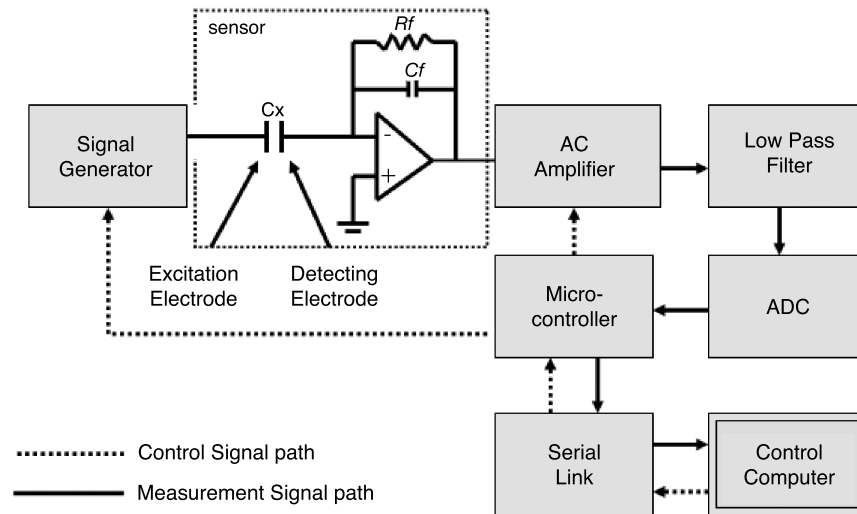
Ultrasonic is a non-destructive sensor and has been successfully applied in process measurement particularly in flow measurement [9]. Ultrasonic tomography system is based upon interaction between the incident ultrasonic waves (frequency of 18kHz to 10MHz) and the object to be imaged. For example, the incident waves may be reflected from the boundaries, the reflection would be sensed and all collected data analyzed to indicate the location of the boundary. The interactions are related closely to density, thus the object or field of interest must contain significant variations in density.

In ultrasound tomography, the required equipment includes ultrasonic generator, transducers to transmit and receive ultrasonic waves and computerized image-processing system. The ultrasonic tomography is hard to be presented in pneumatic conveyors where the transport velocity is high. The speed of sound in gas limits the data acquisition rate and particle impact on the flow pipe and sensors may produce very high level of noise at transducer. In addition, ultrasonic is somewhat a danger system as the transmitter is usually driven by hundred of volts. On the other hand, this tomography method has an advantage of being able to provide accurate cross-sectional view of soft tissues.

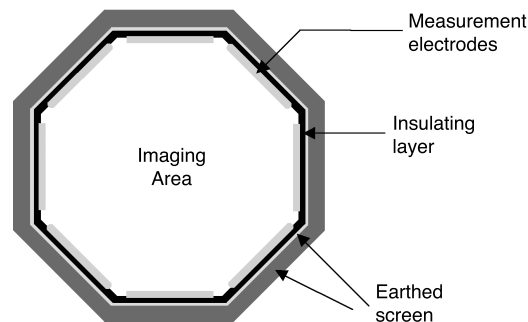
## 2.0 HARDWARE DESIGN

Figure 4 shows a simple block diagram of the current project.

The first stage of this project is electrode sensor design. Electrode sensor design is actually a pipeline sensor with electrode plates as the detecting sensor. In this project, eight electrodes will be constructed symmetrically in octagon shape as shown in Figure 5. This octagon shape sensor is built due to the bare



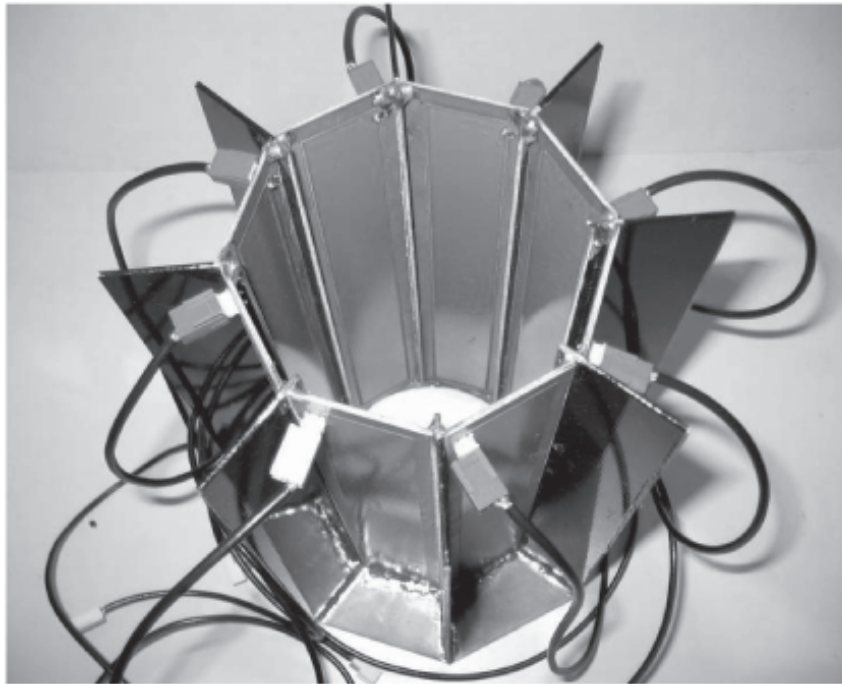
**Figure 4** Block diagram of the ECT system



**Figure 5** Cross-sectional view of the ECT sensor with 8 measurement electrodes

Printed Circuit Board (PCB) is used to be the measurement electrodes. The PCB has the copper surface where by the conductivity is much better than other materials.

Figure 6 shows the top view from the first prototype of the electrodes sensor. The electrode plates are mounted in octagon shape with the space between them being either gas or other materials (in this case, it would be fire flame). A Bunsen burner is purposely used to generate the fire flame inside the pipeline sensor. Thus the sensor must be exposed to open air since combustion needs oxygen. This fire flame would produce standing capacitance between the measuring electrodes that will be measured for the use of image reconstruction.



**Figure 6** A top view of the first prototype electrodes sensor

Copper plate is chosen to be the electrodes in this project due to the consideration of cost, material's conductivity and the convenience of buying the material. Table 1 shows some examples on materials typically used as electrode plates together with their value of conductivity.

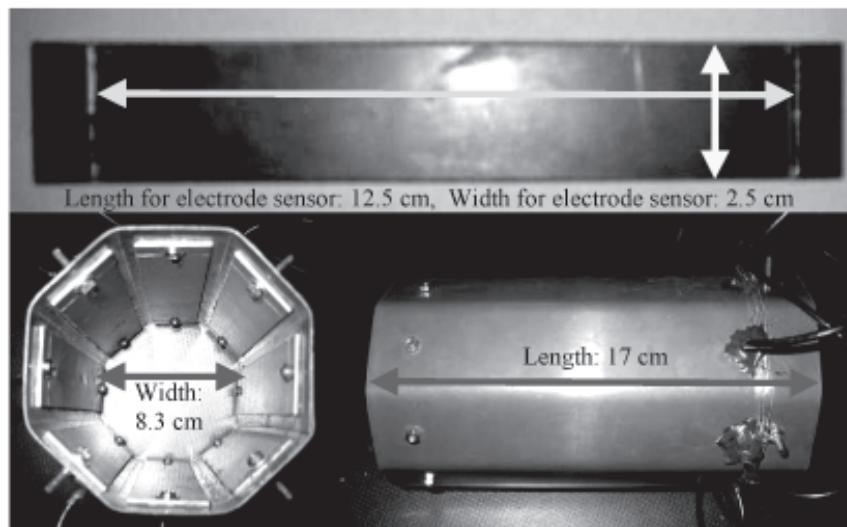
The spatial resolution of a tomographic imaging system depends on the number of independent measurements and the fineness of sensitivity focus for each measurement [3]. Therefore, more electrodes with smaller size would result in better imaging reconstruction. However, the measurement sensitivity of a capacitance is proportional to the electrode profile. As the electrode size reduces, the signal to noise ratio (SNR) of the system decreases. In order to improve the SNR of the measurement, the size of the electrode can be increased, limited only by installation restrictions and cost consideration. Thus, the noise level of the AC based measuring system limits the minimum size. Figure 7 describes the dimension enclose the final prototype of this project.

As a conclusion, the electrode size has to be reduced as the total number of electrodes increases. The selection of electrode dimensions is a matter of balancing between the spatial imaging resolution and SNR.



**Table 1** List of conductivity

Material	Conductivity
Silver	$6.17 \times 10^7$
Copper	$5.80 \times 10^7$
Aluminum	$2.82 \times 10^7$
Brass	$2.56 \times 10^7$

**Figure 7** The real dimension of the fire-flame measuring sensor

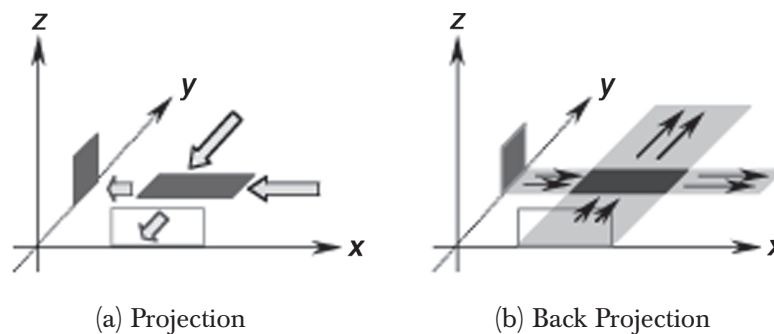
### 3.0 IMAGE RECONSTRUCTION - LINEAR BACK PROJECTION

In process tomography, image reconstruction can be defined as a way to produce a cross-sectional image based on the data obtained from measurement circuits. Rather than reading the data obtained in digital values, the reconstruction image could directly show the concentration profile of the measured materials. Generally, there are various ways of reconstructing an image with subject to constraint of the final result should be the same as the original view [10]. In image reconstruction, the projection data can be imaging as one-dimension image. There will be more one-dimension image generated if the numbers of projection is increased [12]. Actually, image reconstruction can be modeled as a mathematical model using an integral form (Radon Transform), algebra form (spatial domain back projection) or iterative form. Those mathematic models used to combine the 1-Dimension to be a 2-Dimension image in which the



output of the algorithm is the 2-D image. In order to visualize the image, a color scale with the range of numeric result can be used to represent a range of numeric data. The 2-D image is reconstructed by using mathematical model and the calculated result is shown in numeric form.

Among the many reconstruction methods, back projection is the most fundamental method used for image reconstruction in tomography processes [11]. Though the principle is simple, the implementation is quite complicated. The principle claimed that each projection results in shadows around the boundary at opposite direction of projection if there is an object between the two boundaries [11]. The shadowing effect is known as 'projection' or sometimes called projection data. Projection contains a set of measurements where the number of measurement depends on the amount of sensors on the boundary. To construct the image, all the projections are back projected to its original direction. All the spaces lay on the projected ray are mark of with corresponding ray's amplitude. Then, the back projected rays are superimposed in order to obtain the image. The idea can be briefly illustrated as in Figure 8 below.



**Figure 8** (a) Projections to a rectangular object are measured in the  $x$  and the  $y$  directions, (b) These measurements are then projected back to form an image

In order to reconstruct the image in a simple way, the linear back projection algorithm (LBP) is selected as the algorithm to obtain the concentration profile for the cross-sectional image. This is done by combining the projection from each sensor with its calculated value (weight) of sensitivity map. In this case, the sensitivity matrices are used as the tool to represent the image plane for each view. Therefore, for image reconstruction, each sensitivity matrix is multiplied by its corresponding sensor reading. This is just like back projecting each sensor reading to the image plane individually. Consequently, a matrix is obtained, in which the  $m$  represents the number of obtained projection and the

$n$  is the reconstructed image resolution of the used sensitivity matrix. The same elements in these matrices are summed up to provide the back projected voltage distributions. The entire process can be expressed mathematically as follow:

$$V_{LVP}(x, y) = \sum_{Tx=0}^7 \sum_{Rx=0}^7 S_{Rx, Tx} \times \overline{M}_{Tx, Rx}(x, y) \quad (2)$$

where by the

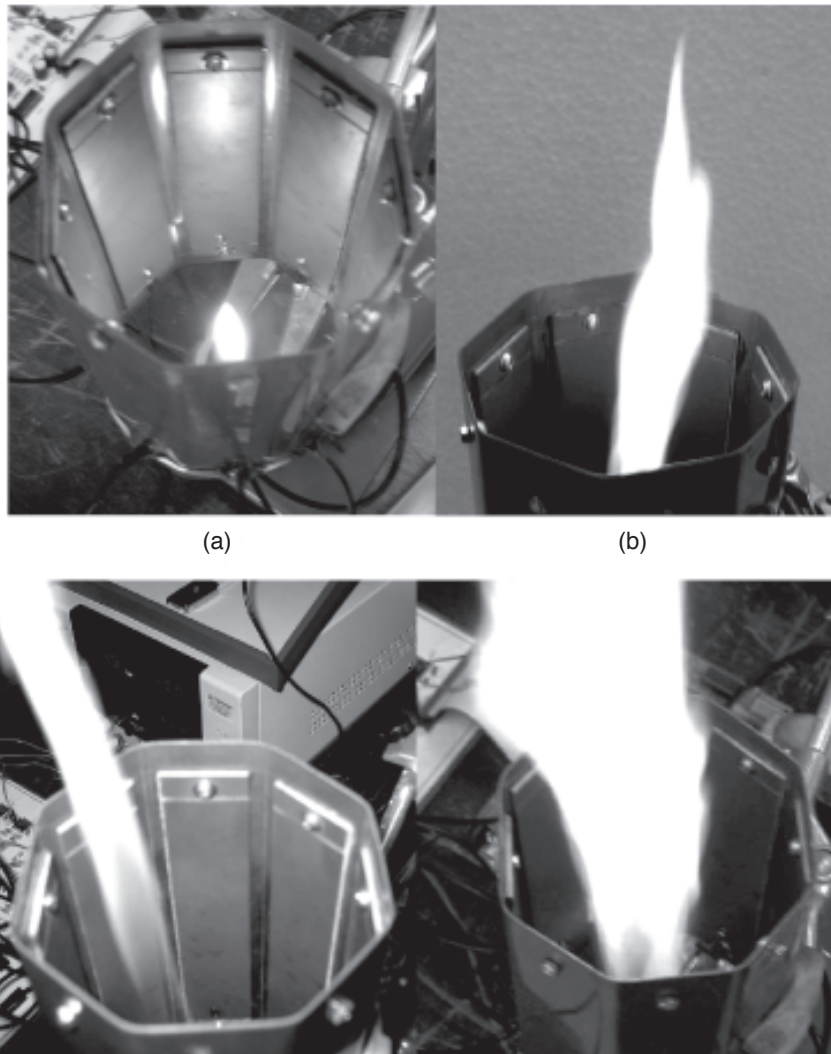
- $V_{LBP}(x, y)$  = represents the voltage distribution obtained by using LBP algorithm (concentration profile in unit of volt), in  $n \times n$  matrix in which  $n$  equals to the dimension of sensitivity matrix.
- $S_{Rx, Tx}$  = represents the signal loss amplitude of the detector  $Rx$ -th for the projection of  $Tx$ -th in unit of volt.
- $\overline{M}_{Tx, Rx}(x, y)$  = represents the normalized sensitivity matrices for the view of  $Tx, Rx$

#### 4.0 RESULTS

The first experiment is carried out to reconstruct the cross-sectional image of the combustion fire flame inside the vessel. When the combustion produces the heat and light within the electrodes sensor, all the data will be collected by the microcontroller and the control computer for image reconstruction. As shown in Figure 9, there are 4 types of combustions that may happen during the testing, and the corresponding reconstructed images could be shown in Figure 10.

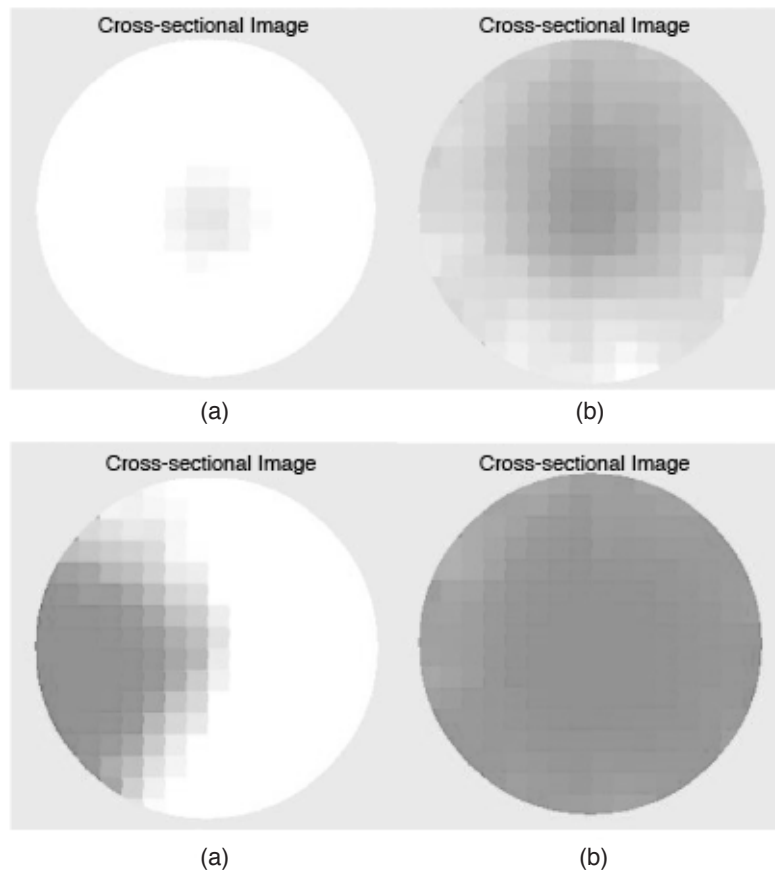
From the results, reconstruction image clearly shows the location and the distribution of the fire flame within the electrodes sensor, showing the location of the fire flame. Besides, the reconstructed cross-sectional image will also tell whether the fire flame is small, large or maximum.

The next result shows on a series movement of the fire flame which is directed to different position in the electrodes sensor. Starting from the centre zone, the fire flame was directed upward, and moves around from electrode 1 to 8 in clockwise direction. As the combustion is uneven, the reconstructed image may different from the eyesight. Further more, the sensitivity at the centre part is very low due to the signals are very small and considered far away from the electrodes. Figure 11 shows the movement of the fire flame inside the sensing region while Figure 12 shows the corresponding cross-sectional image on each position. However, when the fire flame becomes larger, the corresponding cross-sectional image on each position has been shown in Figure 13.

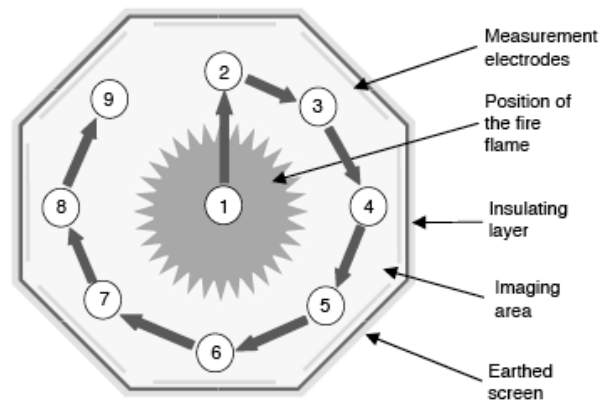


**Figure 9** Combustion in the electrodes sensor. (a) small fire flame (b) the larger fire flame (c) the fire flame is directed to edge of the vessel (d) the fire flame is adjusted to maximum

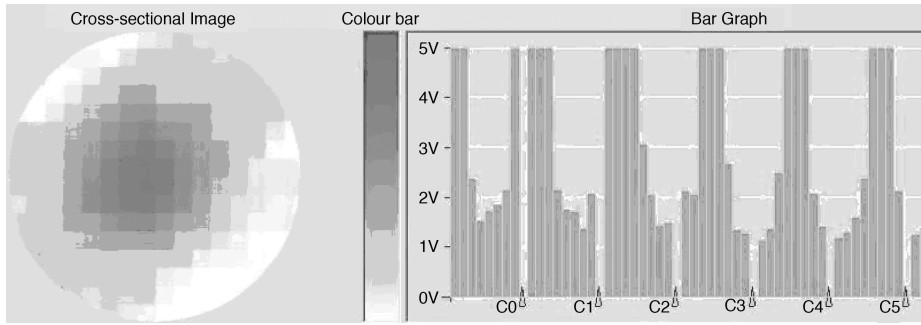
The results above prove that the position of the fire flame can be identified by using the ECT system. The distribution of the fire flame in the electrodes sensor can be monitored online. As a conclusion, a hardware system and the software programming that able to provide real time cross-sectional image have been developed.



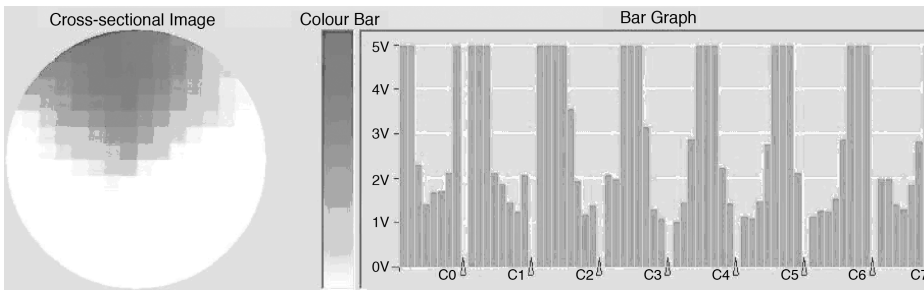
**Figure 10** The corresponding cross-sectional image due to the combustion as shown in Figure 9. (a) small fire flame (b) the larger fire flame (c) the fire flame is directed to edge of the vessel (d) the fire flame is adjusted to maximum



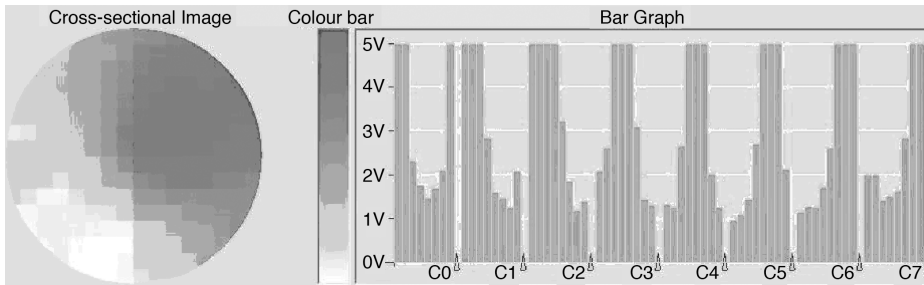
**Figure 11** Movement path of the fire flame



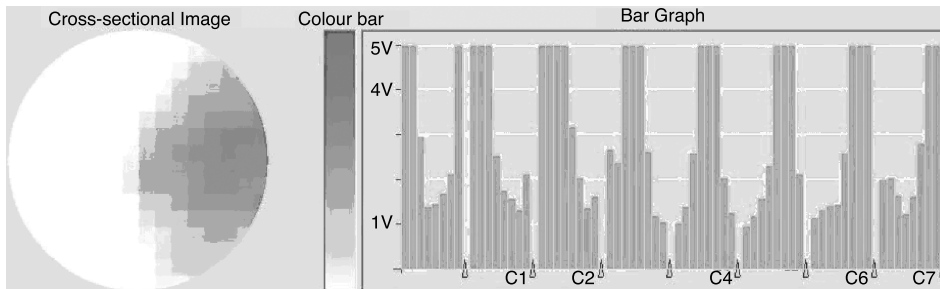
(a)



(b)



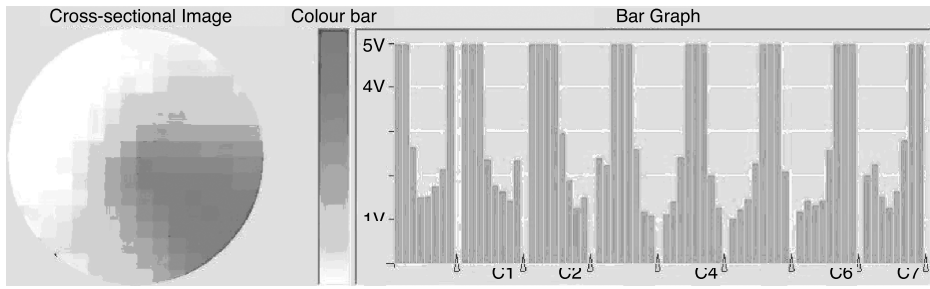
(c)



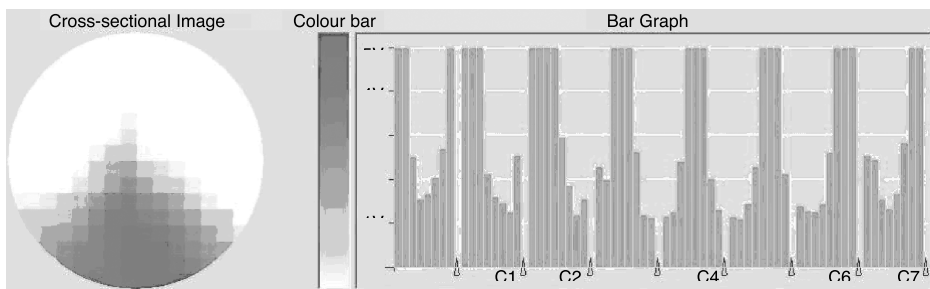
(d)

*Cont.*

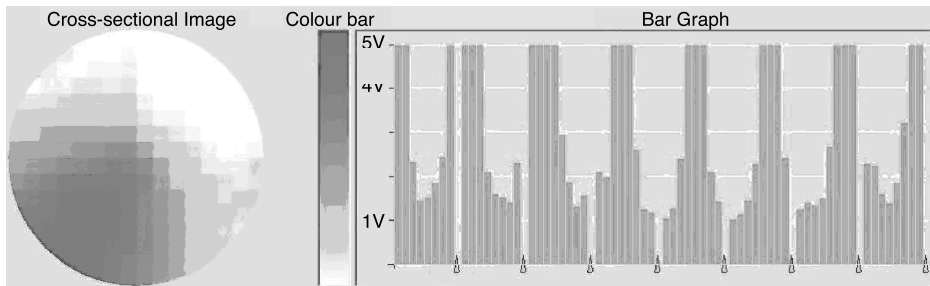
**Figure 12** (a), (b), (c) and (d)



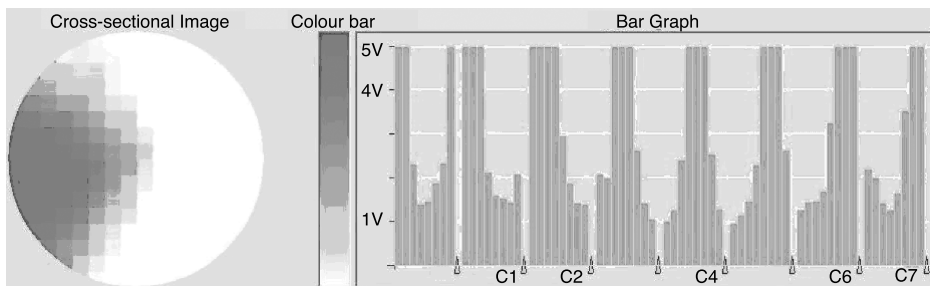
(e)



(f)



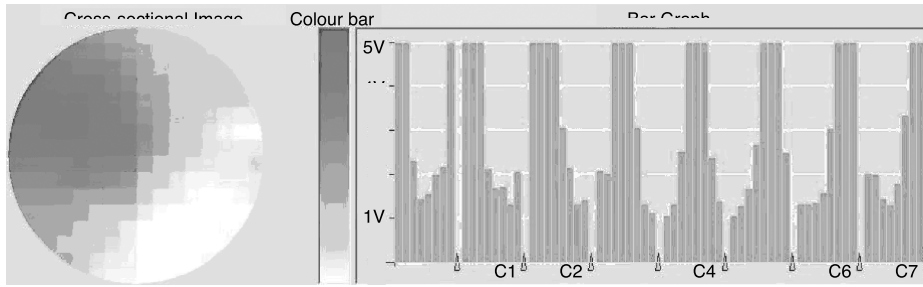
(g)



(h)

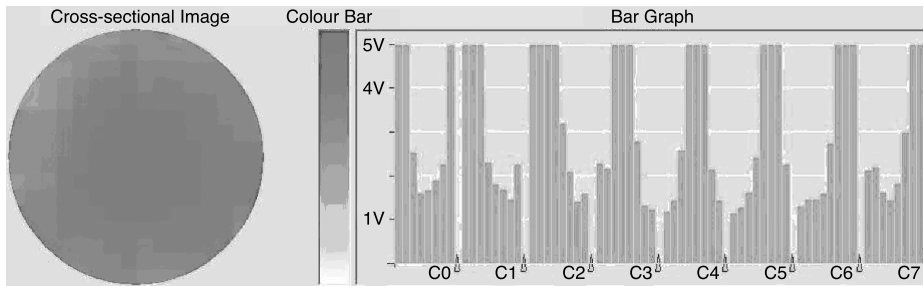
Figure 12 (e),(f),(g) and (h)

cont.

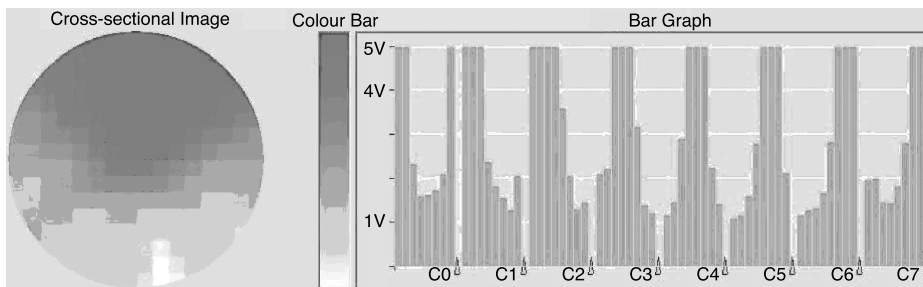


(i)

**Figure 12** The different cross-sectional image constructed corresponding to the different locations of the fire flame as shown in figure 12 (a) Position 1 (b) Position 2 (c) Position 3 (d) Position 4 (e) Position 5 (f) Position 6 (g) Position 7 (h) Position 8 (i) Position 9



(a)

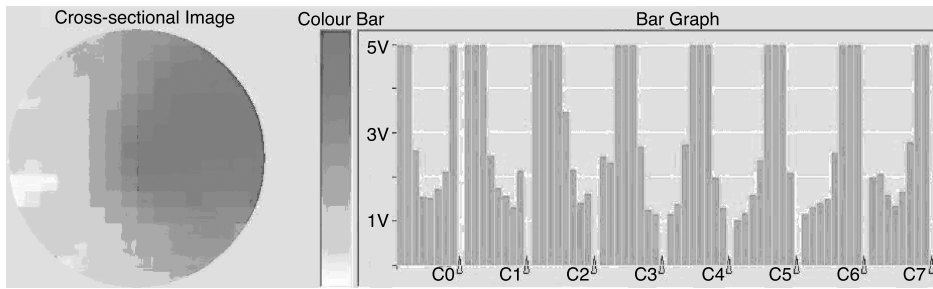


(b)

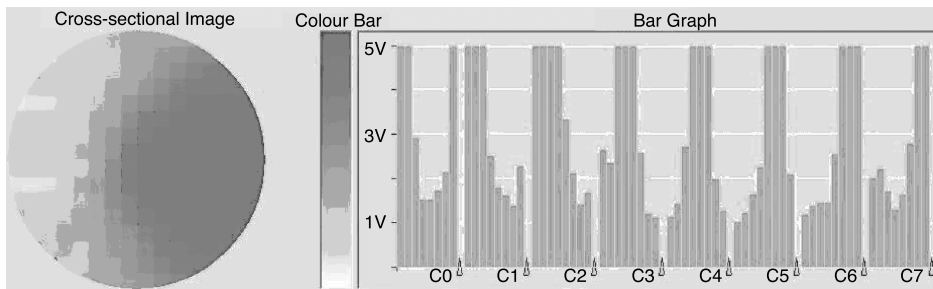
**Figure 13** (a) and (b)

*cont.*

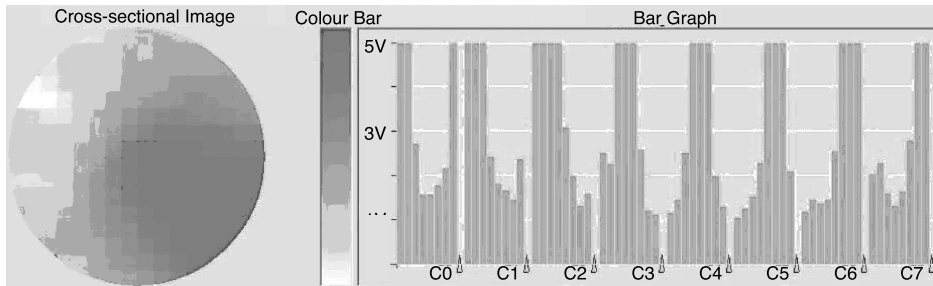




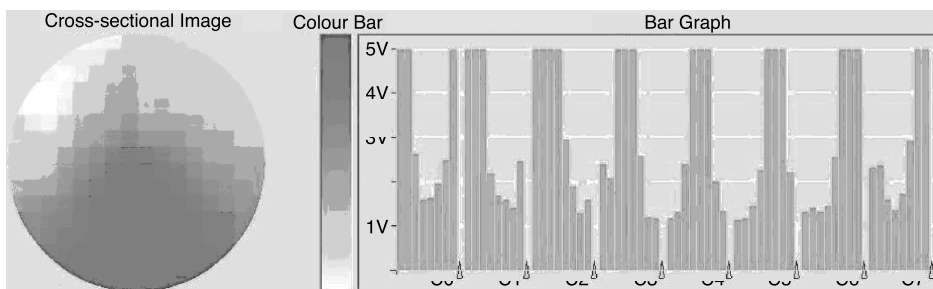
(c)



(d)



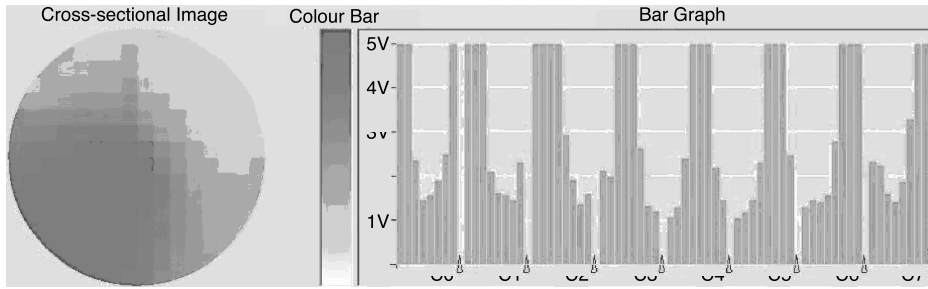
(e)



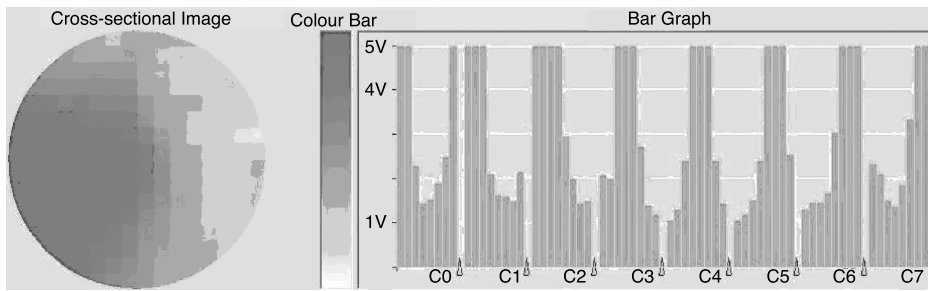
(f)

Figure 13 (c - f)

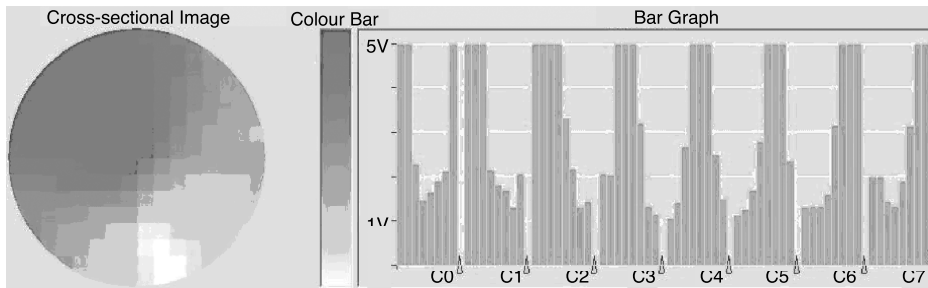
Cont.



(g)



(h)



(i)

**Figure 13** When the fire flame is stronger, the different cross-sectional image constructed corresponding to the different locations of the fire flame in figure 12 (a) Position 1 (b) Position 2 (c) Position 3 (d) Position 4 (e) Position 5 (f) Position 6 (g) Position 7 (h) Position 8 (i) Position 9

## 5.0 CONCLUSION

As a conclusion, a hardware system and software programming to provide the real time cross sectional image of the ECT system have been developed. The system can be used to investigate the distribution of the fire flame within the vessel.

The microcontroller is also able to collect digital data from the capacitance measuring circuit and send to a control computer through a serial communication protocol.

## REFERENCES

- [1] Williams R. A. and M. S. Beck. 1995. *Process Tomography - Principles, Techniques and Application*, Butterworth Heinemann Ltd, Oxford, Britain
- [2] Beck M. S., E. Camporande and E. A. Hammer 1994. Process Tomography-A Strategy for Industrial Exploitation. Pre-Conference Edition, ECAPT. pp 25-32.
- [3] Huang S. M., C. G. Xie, D. Snowden and M. S.Beck. 1992. Design of Sensor Electronics for Electrical Capacitance Tomography. *IEE Proceedings-G*, 39(1): 83-88.
- [4] Yang W. Q. and T.A. York, 1999. New AC-based Capacitance Tomography System. *IEE Proc. Sci., Meas. Technology*, Vol.146, No.1. pp 47-53
- [5] Yang W. Q. 2001. Further Development In An AC-Based Capacitance Tomography System. Dept. of Electrical Eng. and Electronics, *Review of Scientific Instrument*. 72(1): 3902-3907.
- [6] Abdul Rahim R. 2004. Optical Tomography System for Process Measurement Using LED as a Light Source. *Journal Optical Engineering*. 43(5):1251-1257
- [7] Chan K.S. 2002. Tomographic Imaging Of Pneumatic Conveyor Using Optical Sensor. *World Engineering Congress*. July 2002, Kuching, Sarawak, Malaysia. Page 53-57
- [8] Pang J.F. 2004, Infrared Tomography Sensor Configuration Using Four Parallel Beam Projections. *3rd International Symposium on Process Tomography*. Lodz, Poland. 9-10 September 2004, page 112-117
- [9] Fazalul Rahiman M.F. 2004. Monitoring Liquid/Gas Flow using Ultrasonic Tomography. *3rd International Symposium on Process Tomography*. Lodz, Poland. 9-10 September 2004, page 121-125.
- [10] McCann H., W. Q. Yang and N. P. Polydorides. 1999. Information Retrieval by Electrical Capacitance Tomography: Evaluation of an Iterative Algorithm and the Importance of Boundary Conditions, *Proceedings of 1st World Congress on Industrial Process Tomography*, Buxton, UK. pp206-210
- [11] Waterfall R.C., Wolanski R. He, P. and Z. Gut. 1999. Monitoring Flame Position and Stability in Combustion Cans Using ECT. *Proceeding of 1st World Congress on Industrial Process Tomography*. Buxton. pp 167-172.
- [12] Yang W. Q., D. M. Spinkz, J. C. Gamioy and Becky M. S. 1997. Sensitivity Distributions of Capacitance Tomography Sensors with Parallel Field Excitation. *Meas. Sci. Technol.* 8: 562-569.