

Hardware in the Loop of Two Rotors Platform

Nur Amalina Musa*, Shuhaimi Mansor, Airi Ali

Aerolab-UTM, Faculty of Mechanical Engineering, Universiti Teknologi Malaysia, 81310 UTM Johor Bahru, Johor Malaysia

*Corresponding author: nur.amalina@rocketmail.com

Article history

Received : 2 Sep 2013
 Received in revised form : 14 Jul 2014
 Accepted : 24 Aug 2014

Graphical abstract

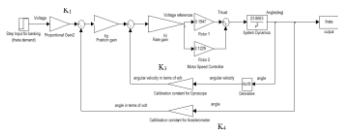

Abstract

This study is aimed to control unstable platform by introducing control system design through low-cost test rig for two rotor system with a feedback control. The rig is used to control the bank angle by adjusting the thrust from each rotor and useful as a teaching aid in control system design. In this paper, the transfer functions of the dynamic system for the two rotor platform was derived and introduce into the controller system. Inertia Measurement Unit (IMU) was installed to provide feedback to the control system. MATLAB Simulink is used to simulate the response of the system before going to the real application while LabVIEW is used to interface the hardware interface and programmed the control system.

Keywords: Two rotors, rotor, platform, open loop, closed loop

© 2014 Penerbit UTM Press. All rights reserved

Nomenclature

L	Angular momentum (kg.m ² /s)
I	Moment of inertia (kg.m ²)
M	Moment of force (N.m)
m	Mass (Kg)
T	Thrust(N)
$\ddot{\theta}$	Angular acceleration (rad/s ²)
b	Width (m)
c	Length (m)
d	Distance between pivot to edge of the motor(m)
ΔT	Variation of thrust (N)
θ	Angle (degree)

ω_n	Natural frequency (rad/s)
S	Laplace domain
ζ	Damping ratio
V_{ref}	Voltage references (volt)
K	Calibration constant
V	Volt (V)
K_R	Rate gain
K_P	Position gain
t_s	Settling time (seconds)
M_p	Maximum overshoot
ω_d	Damped frequency (rad/s)

1.0 INTRODUCTION

Currently, quadrotor becoming popular platform for unmanned aerial vehicle (UAV) as compare with fixed wing due to the fact that they provide a better maneuverability and low-cost in manufacturing, operation and maintenance [1,2]. Control system was defined as a mechanical or even electronic system which is used to maintain the desired output [1]. The objective of control system design is to design and implement a control strategy such the actual output of system is equal to desired output or the references signal [3]. The implementation of control system in aircraft becomes useful tools since it helps pilot to control the aircraft in order to fulfill the mission profile and achieving level 1 flying handling qualities. The goal of this study is to develop a control system which can maintain platform banking angle by controlling the thrust produced by the rotors. It is also used as a

teaching aid material in Control Engineering subject in order to relate the theories with practical application.

Rotary system for unmanned aerial vehicle (UAV) promote a better potential in control community as compared to fixed wing UAV due to their enhanced maneuverability like able to fly in confined space such as urban environments or even small indoor spaces [4,5]. However, the high thrust to weight ratio become a technical challenges in implement the rotary system so that the careful choices of batteries, electric motors and rotors will be essential [5,6].

For this particular study, two low-cost rotors were used while the platform were made up from balsa wood as it is easy to fabricate but this exhibit unstable platform thus cause an issue in control authority of the platform. At the same time, this design can significantly lower the mechanical complexity thus reduce the cost of operation and maintenance [7]. In this paper, the approach is to design a control system with a closed-loop feedback to

improve the steady state and transient response hence able to control the platform [4]. A simple lightweight test rig with one degree of freedom configuration combined with hardware in the loop will be used as to implement the control strategy [5]. The platform is controlled by varying the speed of rotation of each motor. The left rotor rotates in clockwise direction while the right rotor rotates in counter-clockwise direction in order to balance the torque created by the spinning rotors. The relative speed of the left and right rotors is varied to control the bank angle of the platform. However the dynamics of the two rotors can make the vehicle difficult to control. However, the implementation of the control system has made it possible to design and able to fly with satisfied handling qualities [8].

2.0 MATHEMATICAL MODELLING OF TWO ROTORS PLATFORM

An accurate estimation of parameter is essential as the development of a mathematical model for the dynamics of any aircraft is extremely beneficial to control system design and characterization of handling qualities [1].

The derivation of dynamics system was based on the mechanism of the system. Then, it was transformed into transfer function using Laplace Method. There are several assumptions were made during derivation of mathematical model such as, assuming a linear relationship between variables while ignoring small effect in the system, the system is not influenced by surrounding and using lump parameter estimation [3].

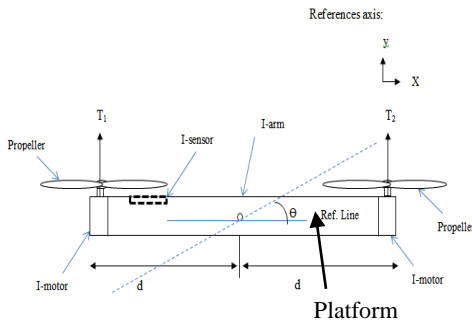

Figure 1 Schematic diagram of two rotor platforms

The two rotor test system was made from balsa wood to be as lightweight as possible to provide sufficient lift to the system [5]. The rotors were mounted on both ends of the balsa wood and constrained to rotate in one degree of freedom at its pivot point. The platform must be leveled in initial condition. Thus the system is said to be in statically stable condition [9]. The two rotors will produce an upward lift which is controlled by the motor controller. The desired input angle will be fed into the motor controller as a command for the system to maintain at a certain angle. Once the platform has stabilized at level condition, the platform will receive a signal to change the speed one of the rotor to allow it to bank at a certain desired angle. The controller reads the bank angle data from IMU 5-degree-of-freedom sensor and compare it with the input angle as commanded by user. This system is known as a closed loop or feedback system. The system was designed to control banking using two rotors at both ends. The result is a couple moments due to rotor thrust created the angular motion to the platform, so that the analytical dynamics of the test system will involve couple moments and angular acceleration.

$$\sum M = I\ddot{\theta} \tag{1}$$

The summation of moments was referring to the thrust of the one rotor multiply by length of arm minus the others rotor thrusts, T multiply by the length of the arm. Since the moment created will be in opposite direction to each other, then the summation of moments is simply depend on the differences between the thrust of the two rotors.

$$\sum M = (T_1 - T_2)d = I\ddot{\theta} \tag{2}$$

The value of the mass moment of inertia for the system can be defined by:

$$\sum I = I_{Motor} + I_{Arm} + I_{Sensor} + I_{Pin} \tag{3}$$

For the pin and sensor, its contribution to the total mass moment of inertia is too small and hence can be neglected. The motor were approximated as rectangular cuboid solid.

$$I_{cuboid} = \frac{1}{12}m(b^2 + c^2) \tag{4}$$

So,

$$I_{motor} = \frac{1}{12}m_{motor}(b^2 + c^2) + m_{motor}d^2 \tag{5}$$

Thus, the total mass moment of inertia is:

$$\sum I = 2I_{Motor} + 2I_{Arm} \tag{6}$$

Therefore, the final dynamic equation is a relationship between rotors thrust to the angular acceleration that would be experienced by the platform.

The input will be thrust; T and the output will be the angle displacement, θ . Since the thrust comes from the difference between two rotors and using Laplace transform to convert the dynamic system from time domain to s-domain:

$$\frac{\theta}{\Delta T} = \frac{d}{I_{Total}S^2} \tag{7}$$

Analysis of the characteristic equation on the system gives $\omega_n = \zeta = 0$. Physically the system behaves neutrally stable where the platform remains at a new position once it's been displaced from initial position [9].

Furthermore, a control system is an interconnection of components forming a system configuration which will provide a desired system response. Another block diagram was needed in order to convert from one unit condition to others unit condition to get desired output same as the demand input. By referring to Figure 2, it represents that the thrust variation multiplies with the system transfer function will yield banking angle. Physically, the thrust value is represented by reference voltage feed to the PMW circuit or known as motor speed controller for this case [10].

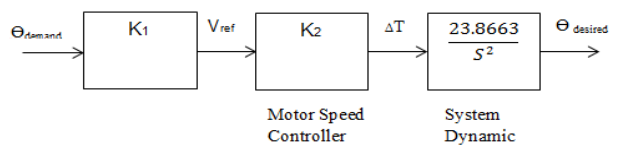

Figure 2 Relationship between angle demands to angle desired

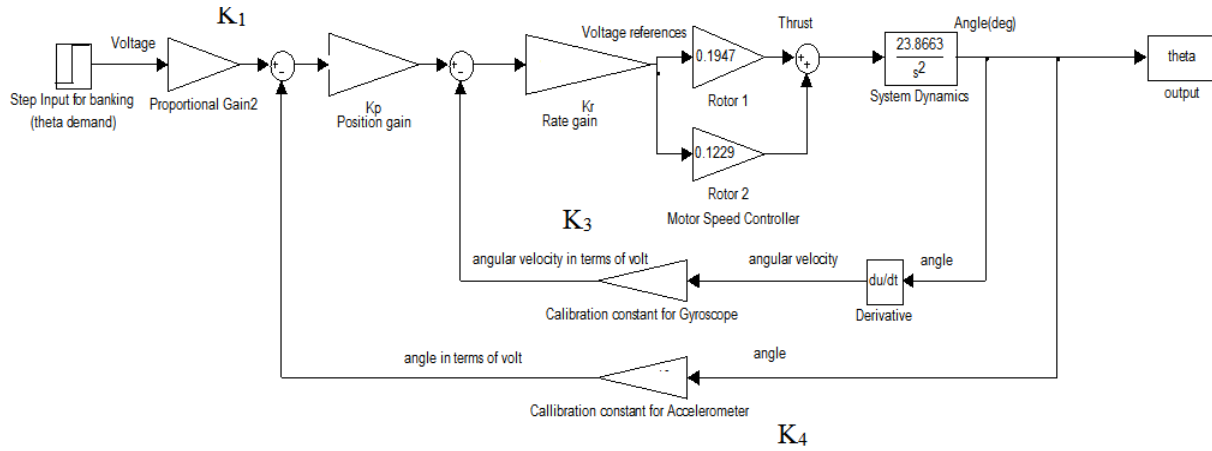

Figure 3 Block diagram for the control strategy of the system

K_1 and K_2 are simply a scalar value that will be defined from the experimental while for the IMU 5 degrees of freedom the gain value were based on calibration constant stated in manufacturer datasheet (K_3 =gyroscope, K_4 =accelerometer) [11].

In this study, the classical control approach will be used to design a closed loop feedback control and implemented in MATLAB Simulink to tune the complex control algorithms [12]. The inner loop which is known as the stability augmentation system (SAS) were used to stabilize the system by improving the steady state while the outer loop known as the autopilot is used to improve the transient behavior in order to maintain the position of the platform [9]. The block diagram is rearranged to become:

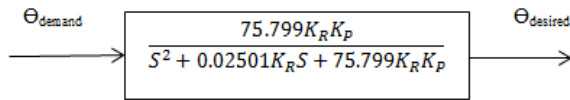

Figure 4 Relationship between angle demands to angle desired

The values in Figure 4 were based on our case study. Referring to the short period flying qualities chart [9], for the good handling qualities, it is stated that the needed values for Level 1 handling quality are $\zeta = 0.7$ and $\omega_n = \frac{3.142 \text{ rad}}{s}$ [9]. Referring to Figure 4, the denominator represents the characteristics of the system. By equating to the standard second order equation which is $S^2 + 2\zeta\omega_n S + \omega_n^2 = 0$ thus it becomes:

For the rate gain:
$$K_R = 175.8816 \tag{8}$$

While for the position gain:
$$K_P = 0.000741 \tag{9}$$

These values of gain are simulated in MATLAB Simulink in order to evaluate the response before implementation on real system.

3.0 OPEN LOOP SYSTEM TEST

The open loop of the system is analogous to the joystick control, i.e. the pilot needs to work hard in order to maintain the aircraft to be close to demand input thus prove that the needs for the feedback control [5]. The demand angle input which is unit step and the response are shown by Figure 5.

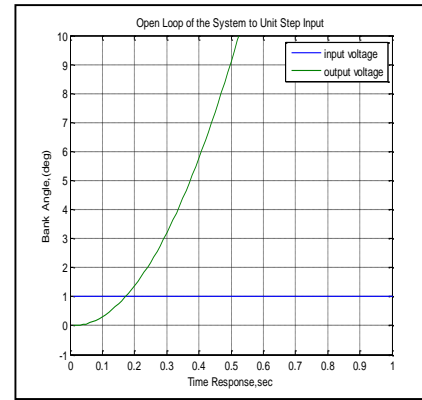

Figure 5 Time response of open loop system to unit step input

The characteristic equation of the open loop system shows when the $\omega_n = \zeta = 0$, the output angle would diverge infinitely. The system is said to be in neither oscillate nor damp over time. Hence, in order to overcome the instability, the feedback loop is introduced to the system. In this case, Inertia Measurement Unit (IMU) is installed to provide physical feedback to the system.

3.1 Closed Loop System Test

In this system, the complete set of hardware consists of IMU 5-degrees-of-freedom sensor to provide feedback, data acquisition system from National Instrument (NI USB 6259) as analog to digital converter, and LabVIEW software was used to imply for closed loop system. The platform states and commands to the rotors are updated every 10 ms or 100 Hz. Figure 6 shows the overall close loop system of the two rotors platform.

Figure 7 shows the schematic block diagram of the flow of the complete system.

Simulation of the complete system shows that the system is satisfied with the general control system theory as the response was decay over time as depicted by Figure 9.

The output response of the system shows an underdamped response in the region of $0 < \zeta < 1$. The rise time of this system was 1 seconds, it is shown by the time taken by the output to rise from 0 to 100% of the steady state value. On the other hand, the settling time is the time of the output response to reach a steady state value and the attitude control of this system is:

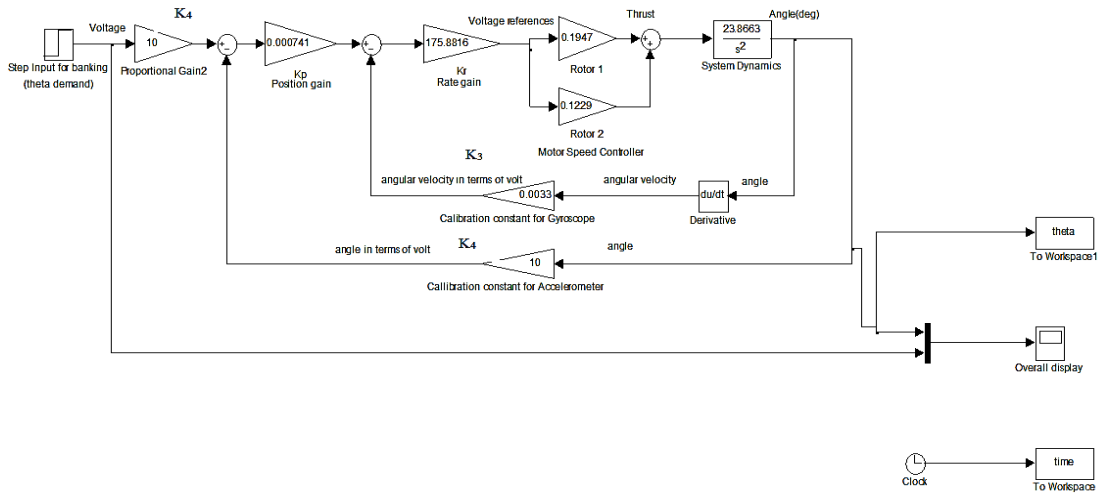

Figure 6 Simulink for closed loop system

$$t_s = \frac{4}{\xi \omega_n} = 1.82s \quad (11)$$

For the maximum overshoot of the system, M_p :

$$M_p = e^{\frac{-\xi \pi}{\sqrt{1-\xi^2}}} = 0.4598 \quad (12)$$

For a unit step, the percentage overshoot is given by $100 \times M_p = 4.5988 \approx 4.60\%$ and this is in function of the damping ratio. Basically, overshoot happened when a signal or function exceeds its target. On the other hand, the damped frequency of the system can be determined from the following calculation:

$$\omega_d = \omega_n \sqrt{1 - \xi^2} = 2.244 \text{ rad/s} \quad (13)$$

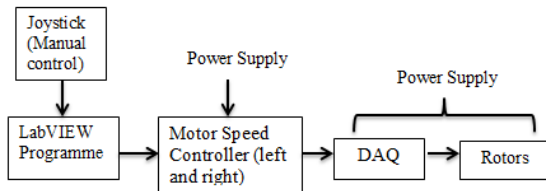

Figure 7 Block diagram of the complete system

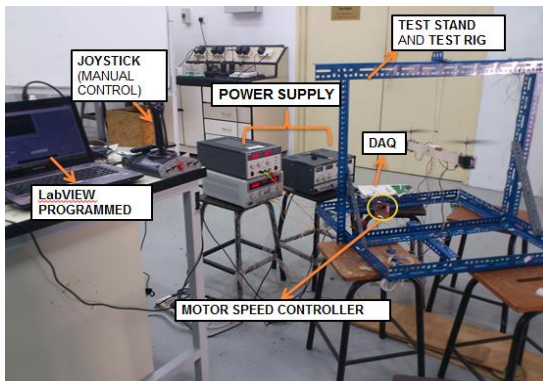

Figure 8 Complete set up of hardware

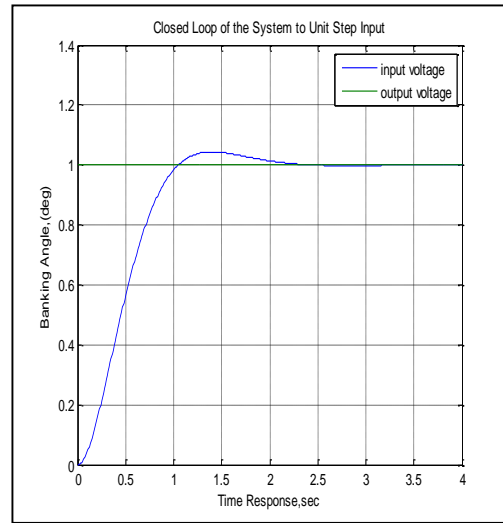

Figure 9 Time response for closed loop gain $K_R=175.8816$ and $K_p=0.000741$

Figure 10 shows the result of the output system response to the demand input from the real test run using calculated rate gain, K_r and position gain, K_p obtained from simulation. The LabVIEW programmed will be used as to implement the design control strategy which previously simulated in MATLAB Simulink.

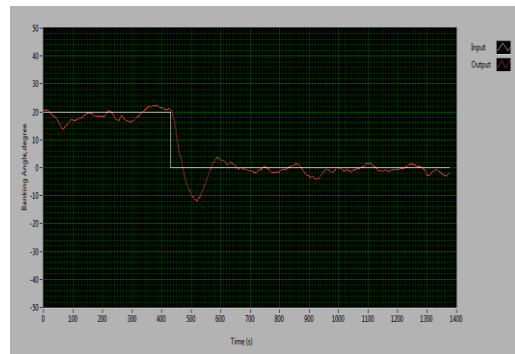

Figure 10 The actual response of closed loop system for gain $K_r=175.8816$ and $K_p=0.000741$

Based on Figure 10, the response represents the actual behavior of the rig whereas the system were purposely designed not to have damping and the rig are in a neutrally stable condition which resulted in sensitive to any disturbances applied to the system. For example, changes from banking angle 20 degree conditions to a level flight condition at 430 seconds cause a sudden deflection to the platform but real system suffers from unavoidable delay [6]. The delays are mainly due to the hardware-software interfacing. Hence, in order to avoid the sudden deflection and delays, the design rig must have either mechanical damping or aerodynamic damping with a rapid real-time update.

The environment disturbance such as ground effect, gust and friction between components cause the response to slightly deviate from the demand input. In this case, the system response was able to maintain the bank angle as demanded.

4.0 RECOMMENDATIONS

It is recommended to use a brushless motor with its speed controller, redesigning the test rig to increase the structural rigidity, perform hardware and software improvement and accurately estimate the mathematical modeling of the system.

5.0 CONCLUSION

It has been found that by applying controller gain with the rate gain, $K_R=175.8816$ and position gain, $K_p=0.000741$ to the closed loop of the system, the time response of the system has become more favorable since its behalf as underdamped response. Basically the rate gains play an important characteristic since they can cause the control loop to become unstable and increase the amplitude of oscillations which will cause the motor to suddenly speed up and damage the rig.

In conclusion, the unstable platform is satisfactory with a mean of the system=9.3628, standard deviation=9.6368 and standard error=0.2599.

Acknowledgement.

The authors gratefully acknowledge use of the services and facilities of the Aeronautics Laboratory (Aerolab) at Universiti Teknologi Malaysia, funded by Flagship Grant (Q.J130000.2424.01G00).

References

- [1] G. Gremillion, and J. S. Humbert. 2010. System identification of a quadrotor micro air vehicle. *AIAA Flight Mechanics Conferences*. AIAA 7644:1–7.
- [2] G. M. Hoffman, H. Haomiao, W. e L and T. Claire J. 2007. Quadrotor helicopter flight dynamic and control : Theory and experiment. *AIAA Guidance, Navigation and Control Conferences and Exhibit*. AIAA 6461:1–20.
- [3] H. Jamaluddin, M. S. Yaacob, R. Ahmad. 2011. *Introduction to control engineering*. Penerbit UTM. Johor Bahru.
- [4] M. Karpenko, P. Sekhavat, J. Park, I. M. Ross. 2010. Closed-loop optimal guidance and control of quadrotor unmanned aerial vehicle. *AIAA Guidance, Navigation and Control Conference*. AIAA. 8051 : 1–11.
- [5] S. Hanford, L. Long, J. Horn. 2005. A small semi-autonomous rotary-wing unmanned air vehicle (UAV). *Infotech@Aerospace*. 7077:1–10.
- [6] S. Bouabdallah, R. Siegwart. 2004. Design and control of an indoor micro quadrotor. *IEEE: International Conferences on Robotics and Automation*. 5:4393–4398.
- [7] H. C. Yang, R. Addousleiman, B. Sababha, E. Gjoni, D. Korff, O. Rawashdeh. 2009. Implementation of an autonomous surveillance quadrotor system. *AIAA Infotech@Aerospace Conference*. AIAA 2047:1–7.
- [8] R. Colgren, R. Loschke. 1997. To tail or two tails? The effective design and modeling of yaw control devices. *AIAA Modelling and Simulation Technologies Conference and Exhibit*. AIAA 4609: 1–13.
- [9] R. C. Nelson. 1998. *Flight Stability and Automatic Control*. Second Edi. University of Notre Dame: McGraw-Hill International Editions.
- [10] G. F. Cook. 1999. "PWM motor speed controller/DC light dimmer," *Home Power Magazine*.
- [11] Cytron Technologies. 2012. "IMU 5 degree of freedom,". [Online]. Available: <http://www.cytron.com.my/>.
- [12] H. C. Yang, B. Sababha, C. Acar, O. Rawashded. 2010. Rapid prototyping of quadrotor controllers using Matlab RTW and dsPICs. *AIAA Infotech@Aerospace*. AIAA 3407:1–6