

# Static and Dynamic Balancing of Helicopter Tail Rotor Blade Using Two-Plane Balancing Method

Mohd Shariff bin Ammoo\*, Ziad Bin Abdul Awal, Norhidayah binti Mat Sangiti

Dept. of Aeronautics, Automotive and Ocean Engineering, Faculty of Mechanical Engineering, Universiti Teknologi Malaysia, 81310 UTM Johor Bahru, Johor Malaysia

\*Corresponding author: mshariff@fkm.utm.my

## Article history

Received 12 Sep 2014  
Received in revised form 20 Sep 2014  
Accepted 1 Oct 2014

## Graphical abstract

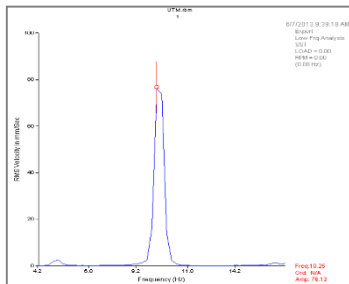

## Abstract

Balancing is a rotating component is critical in any mechanism. Devoid of proper balancing, any vehicle - be it in air, land or sea, it will affect stability, control and safety. The same goes for rotor crafts. Imbalance of the helicopter tail rotor system leads to vibrations in the entire vehicle and may cause accident. Typically, for the tail rotor of a helicopter, the blade is a source of vibration on the tail boom. This not only causes inconvenience to the pilot but also reduces the life span of the helicopter. There is a certain amount of vibration in the helicopter rotor systems especially the tail rotor. Hence, balancing procedure for rotating mass was conducted to reduce the vibration. This research focuses on balancing of the tail rotor for UTM Single Seat Helicopter. Experiments have been conducted in order to study the vibration level of the tail rotor. Adding and removing masses separately on the tail rotor exhibited different vibration levels. The responses were analyzed and used for balancing the tail of rotor system. The balancing effort was considered successful, although there was still some residual unbalance in the tail rotor.

**Keywords:** Correction mass; trial mass; vibration; vibratory acceleration; residual unbalance;

© 2014 Penerbit UTM Press. All rights reserved.

## 1.0 INTRODUCTION

Aviation industry has come long way since the days of Wright brothers. Aerodynamic design, structures and advanced materials are the principal and the most concerted attributes in aeronautics [1-4]. However, all the individual parts can only properly function only if there is proper design. Balancing is a key issue in aircraft design especially for rotating parts. Apposite and clear-cut balancing of aircraft parts and components are vital for aircraft stability and performance. This research focuses on conducting an extensive study on the static and dynamic balancing of the UTM Single-Seat Helicopter tail rotor blade system. The UTM Single-Seat Helicopter is a research helicopter being developed in Universiti Teknologi Malaysia. Figure 1 displays an image of UTM Single-Seat Helicopter which is undergoing extensive research and development process.

There are several approaches towards balancing rotary mass. One of the most prevalent method is by adding or removing weights. Mass is usually added on the tip of single and adjacent blades [5]. As the tip mass increases, the amplitude of the vertical force response also increases while the phase relationship remains unaffected. This can be obtained from the balancing procedure of AH-64 tail rotor as shown in the Figure 2. The slope of this linear line indicates that it is opposite of balance sensitivity coefficient.

Subsequently, in order to minimize vibratory accelerations, linear algorithm is used in the Aviation Vibration Analyzer (AVA) to calculate the amount of weight that must be added or removed from the blade tip. A small weight can also be added or removed from the rotor at any of the fasteners located as shown in Figure 3. Such weights may consist of washers which can be added to or removed from threaded fasteners [6].



Figure 1 UTM single-seat helicopter

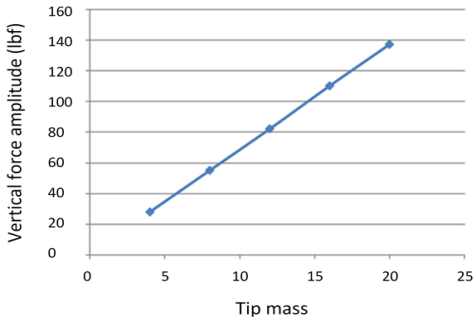

Figure 2 Vertical force amplitude against tip mass [1]

Fundamentally, the method introduced by Helmut involves the attachment of an accelerometer and triggering a stroboscope [6]. Location and the amount of weight that has to be altered can be determined using a multi-coordinate system; which can be established in analog, tabular or digital form. This system consists of three different coordinate scales which are; velocity signal (A), blade angularity (D) and weight values to be added or removed (B and C). Figure 4 shows the multi-coordinate system consisting of three coordinate scales.

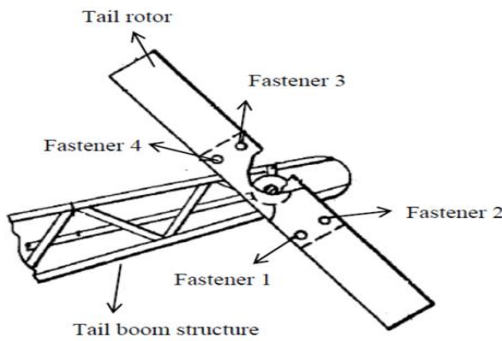

Figure 3 Location of the fasteners where mass can be added or removed [2]

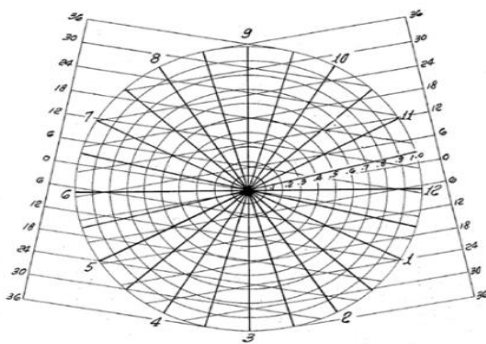

Figure 4 Multi-coordinate systems [6]

Another method of balancing is the neural network approach. According to Ferrer *et al.* vibration occurrence have an almost constant frequency due to the perpetual speed of the rotating parts [7]. Usually this frequency can range from a few Hz to a hundred. Furthermore, airflow leaving the tail surface can cause random vibrations which is also known as tail shake [7]. System based on neural network act as a link to model a transfer function between the adjustment parameters of the rotor and the vibration levels on the first harmonic.

The vibration levels in the aircraft can be written as:

$$v_a^h = H(\alpha_i^j) \tag{1}$$

Here,  $H$  is the transfer function between the adjustment parameters and the vibration levels,  $i$  is the index blade,  $j$  is the parameter type (weight, pitch rod, tab),  $a$  is the accelerometer index and  $h$  is the harmonic. Figure 5 shows the Feed-Forward network chosen to ensure a decent identification of  $H$ . The input layer in the left representing the adjustment parameter and the right layer or output layer represents the Fast Fourier Transform (FFT) coefficients of the vibration levels.

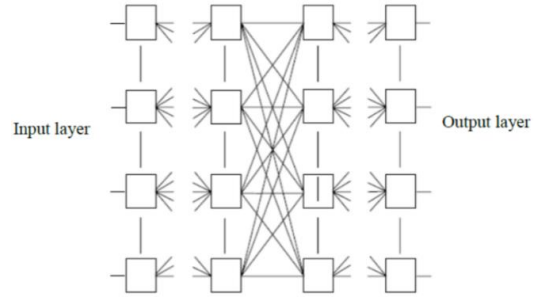

Figure 5 Feed-forward network [9]

The data obtained from the input usually propagates layer by layer. These layers are linked using connections and the processed data is in balanced condition. The network simulates the transfer function between the input and output.

Relocating the shaft axis is another way to perform balancing. In order to avoid any addition or subtraction of material, Heinz suggested the relocation of the shaft axis or the center of mass by making principal inertia axis coincide with the shaft axis as shown in Figure 6 [8]. Nonetheless, it is challenging to make the new center of gravity at the desired corrected location if no material is added.

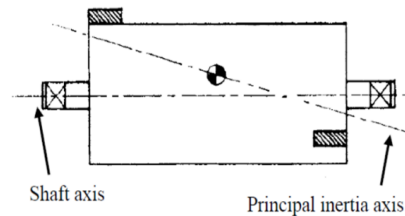

Figure 6 Shaft axis and principal inertia axis [8]

Another way to perform balancing is using Influence Coefficient Method (ICM). Influence coefficient method is about using a known trial masses and relative angular position to determine the sensitivity of a rotor-bearing system. Usually, this method is used for high speed machinery with critical speed like rotary compressors. ICM is an experimental method that was refined by Lund and Tonesson from Goodman [9]. Kang *et al.* then modified the method from two to three trial masses in one balancing plane [10]. This improves the balancing accuracy as the measurement errors are minimized. According to Seve *et al.* ICM uses few balancing planes, several speeds of rotation and target planes [11]. The goal of this method is to obtain the correction mass required to reduce the amplitude of the target planes orbiting at different balancing speeds. Figure 7 indicates the orientation of balancing and target planes.

Correction mass is located at the balancing planes which is proportional to the target planes to measure the vibration level. The equation that can be used here is:

$$q = p \times s \quad (2)$$

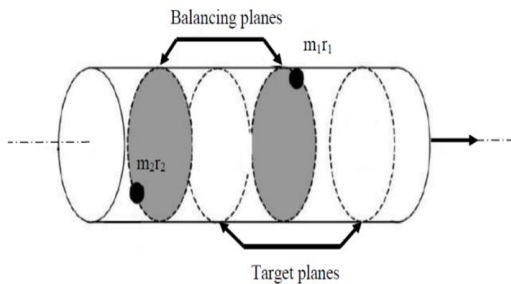

Figure 7 Balancing and target plane definition [11]

Here,  $q$  is the balancing plane,  $p$  is the target plane and  $s$  is the balancing speed. The efficiency of the balancing depends on the position and number of target planes. An influence coefficient matrix is obtained from the data of a set of discrete correction masses which minimize whirl response. The process of applying trial masses is repeated for all balancing planes and the rotor responses are measured. According to Zhou and Shi [12], the basic principle used in the influence coefficient method is:

$$v_W = Cw \quad (3)$$

In this case,  $v_W$  is the magnitude and phase of the rotor imbalance response in complex number,  $C$  is the influence coefficient relating the imbalance and the rotor response in matrix form and  $w$  is the column vector representing the imbalances in the planes. There are two assumptions behind the above equation. These two assumptions will be accepted if the imbalances are not very large. They are:

- Rotor response is proportional to the imbalance.
- The effect of a set of imbalances can be obtained by superimposing each individual unbalance.

Another method is the two-plane balancing method. Trial mass is used during balancing as temporary alterations to the mass distribution of the rotor. The maximum residual mass,  $M_{MR}$  is given by:

$$M_{MR} = \frac{S.U \times M_R}{R_C} \quad (4)$$

In equation (4), S.U. is the specific unbalance required,  $M_R$  is the rotor mass and  $R_C$  is the correction radius. During balancing trial, it is difficult to mount the correction mass at the same radius as the trial mass due to different structure of the rotor as shown in Figure 8. The relation to correct the imbalance is given as follows:

$$\vec{e} = \frac{m\vec{r}}{M} \quad (5)$$

Here,  $\vec{e}$  is the specific imbalance,  $m$  is the imbalance mass,  $\vec{r}$  is the correction radius and  $M$  is the rotor mass. By rearranging equation (5) we get:

$$\vec{e}M = m\vec{r} \quad (6)$$

Therefore,

$$\vec{e}M = m\vec{r} = m\vec{r}_1 = m\vec{r}_2 \quad (7)$$

In Figure 8, the correction mass is mounted at radius  $r_2$ , while trial mass is mounted at radius  $r_1$ . If both radii values are different, the value for correction mass  $m_2$  simply changes to keep the integrity of the product constant. That is to say:

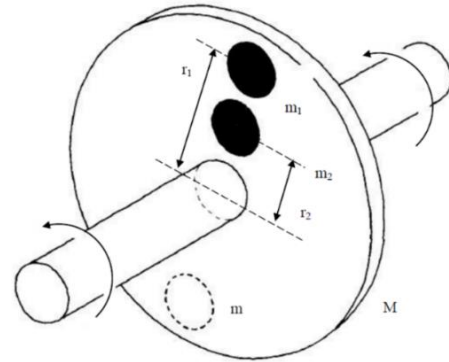

Figure 8 Location for correction mass and trial mass [13]

$$\vec{e}M = m\vec{r} = m\vec{r}_1 = m\vec{r}_2 \quad (8)$$

The correction mass and the angle required can be calculated using a balancing program. The values for the correction mass and the angle required can also be calculated using vector diagram.

## 2.0 EXPERIMENTAL PROCEDURE

After evaluating all the possible approaches, two-plane balancing method has been chosen for balancing the tail rotor blade of UTM Single-Seat Helicopter. Basically four steps have been identified to conduct this balancing process. The initial step is to design and build the model, followed by conducting the vibration test and determining the correction mass necessary as well as checking the residual unbalance.

### 2.1 Model Design And Construction

A test rig is constructed to perform the balancing experiment on the tail section of the helicopter. The test rig aids in connecting the motor, the tail boom and the tail rotor blades together. The tail boom usually experiences the utmost vibration during operation therefore the test rig has to be robust enough to withstand the vibration. In order to run the rotor blades, a motor is placed on the rig and is connected to the tail boom. This experiment is conducted at zero pitch angle. The pitch control of the tail rotor is fixed at the tail gearbox in order to lock its movement and conduct the experiment in a stable condition. All the respective parts, instruments and tools were assembled and installed according to their specified location as shown in Figure 9. As a safety precaution, the experiment is conducted in a wide and open space area as the tail rotor might slip or break due to the increasing speed of rotation. As shown in Figure 10, in order to measure the vibration level, an accelerometer and a tachometer is installed at the tail gearbox where most vibration occurs.

2.2 Vibration Test

In order to measure the vibration level using two-plane balancing method, accelerometer and tachometer are two main equipments to be utilized. The accelerometer is attached at the tail gearbox where it is most affected by the vibration. It is used to produce vibration signal describing the oscillatory motion of the helicopter tail structure. The tachometer is used to measure the speed of the tail blade rotation. The speed of the rotation is controlled between 0 and 330 rpm without any masses being added. Subsequently, the masses are added on the two blades separately. Balancing procedure can be explained through a flowchart as in the Figure 11.

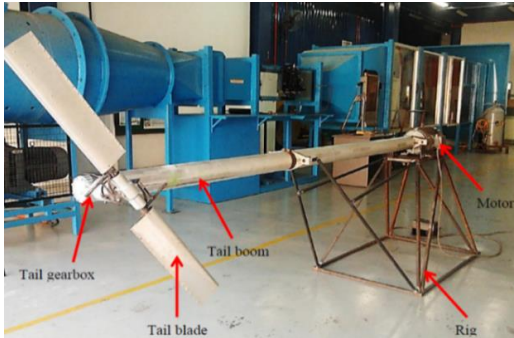

Figure 9 Experimental set up



Figure 10 Accelerometer and tachometer at the tail gearbox

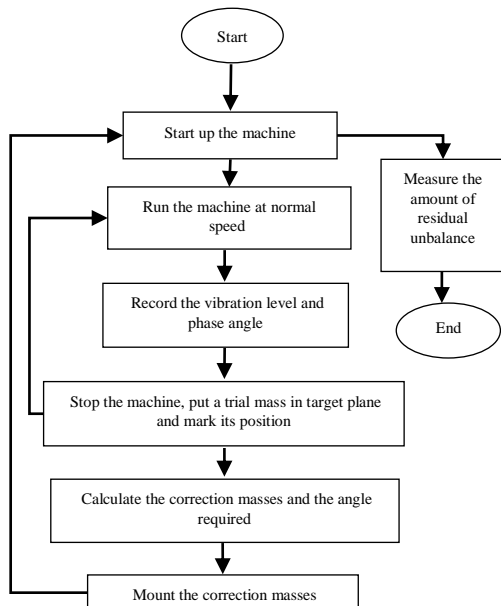

Figure 11 Flowchart for balancing procedure

2.3 Determining The Correction Mass

During the vibration test, trial mass are used before the required correction mass can be mounted. To determine the correction mass needed, a vector diagram calculation was conducted using the trial mass data. The inputs required are the initial amplitude vibration,  $\vec{V}_0$  and the amplitude of the vibration as the trial mass mounted,  $\vec{V}_1$ . These amplitudes are used to draw a line starting from the origin according to their amplitude. The joining of the two tip vectors will indicate the effect of the trial mass alone,  $\vec{V}_T$ . These three vectors can be described using Figure 12. Another  $\vec{V}_T$  line is needed to be drawn from the origin with equal magnitude and direction as the previous  $\vec{V}_T$ .  $\vec{V}_C$  from Figure 12 is the mirror of the  $\vec{V}_0$  representing the position and magnitude of the mass required to balance the unbalance with an angle of  $\phi_C$ .

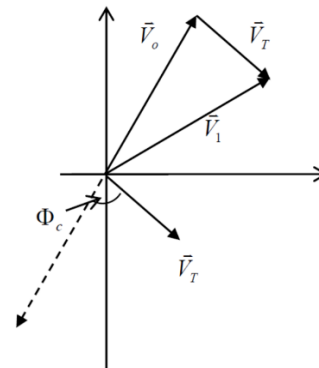

Figure 12 Vector diagram for calculating the correction mass using the trial mass data

Assuming that the amplitude is proportional to the unbalanced mass, the relation below can be established:

$$\frac{M_T}{\vec{V}_T} = \frac{M_{COMP}}{\vec{V}_{COMP}} = \frac{M_o}{\vec{V}_o} \tag{9}$$

In order to find the value of the correction mass and its position relative to the trial mass, the above equation will become:

$$\therefore M_C = M_o = \frac{|V_o|}{|V_T|} \times M_T \tag{10}$$

And the angle required will be:

$$\phi_C = \angle_C = -\angle_T + \angle_o + 180^\circ \tag{11}$$

If  $\phi_C$  gives a positive angle, it is measured in the direction of rotation and vice versa.

2.4 Residual Unbalance

It is quite impossible for a rotor to be perfectly in balanced condition. There will always be some error left after balancing which is usually termed as residual unbalance. This can be measured by graphical method (Figure 13) and using a vibration meter [13].

The vibration level is measured using the CSI 2130 Machinery Health Analyzer in millimeter/second (mm/s) and the accelerometer at the tail gearbox provided continuous vibration data. The vibration amplitudes are measured at every interval angle of 45° with trial mass mounted at its respective angle. A

graph of vibration amplitude against the position can be drawn from the data as shown in the Figure 14.

The plotted graph should approximately project a sinusoidal curve. Otherwise, the residual unbalance is under the limit of reproducibility. This can occur if the trial mass is too small or the measuring sensitivity is inadequate. From the sinusoidal curve, the magnitude of the unbalance,  $V_{res}$  and the distance to the zero line represents the magnitude of the trial mass,  $V_T$ . So, the magnitude of the residual unbalance mass,  $M_{res}$  can then be calculated from the equation below:

$$M_{res} = \frac{|V_{res}|}{|V_T|} \times M_T \tag{12}$$

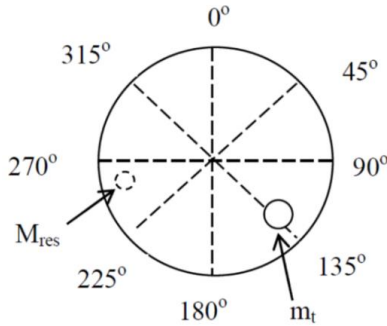

Figure 13 Checking residual unbalance [8]

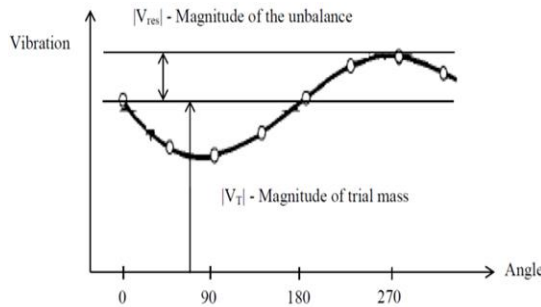

Figure 14 A graph of vibration amplitude against the position of trial mass [8]

### 3.0 RESULTS AND DISCUSSION

The purpose of this experiment is to get the vibration level and response data for the UTM Single-Seat Helicopter in order to balance the tail rotor blades. Vibration levels during zero mass addition and after addition of the mass at the two blades were found to be different and intermittent. In this experiment, the tail rotor speed has been kept steady at 660rpm. The vibration level without any mass added acts as a reference to compare with the data after the added mass. Figure 15 displays the graph of vibration level against frequency obtained using CSI 2130 without any mass added on either blade. The highest value is 76.13 mm/s of vibration occurring at 10.25 Hz.

High amplitude vibration was been found for the rotor and therefore mass is required to be added on either blade. The responses are then analyzed and extensively studied. Table 1 shows all the data obtained during the experiment. Washers have been used as mass and added at both blades separately. Figure 16 indicates where the masses have been added.

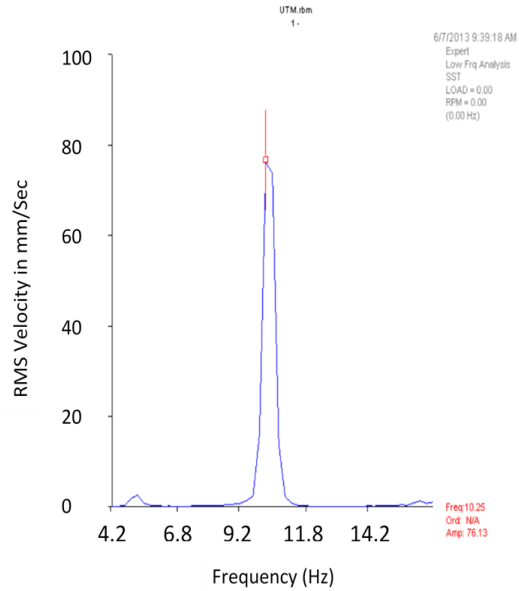

Figure 15 Vibration level without any mass added

Table 1 Experimental data

No.	Mass Added, ( $10^{-3}$ ) kg		Frequency (Hz)	Vibration Levels (mm/s)
	Blade 1	Blade 2		
1	0	0	10.25	76.13
2	2.4	0	10.50	68.61
3	4.8	0	10.25	78.58
4	7.2	0	10.50	78.97
5	9.6	0	10.50	83.06
6	0	2.4	10.50	63.01
7	0	4.8	10.50	61.46
8	0	7.2	10.50	56.91
9	0	9.6	10.50	55.55
10	0	13.2	10.50	52.48



Figure 16 Location of the washers

A graph of vibration levels against mass added has been plotted for each blade. Figure 17 displays the vibration trend for both blades. It is clearly seen that for Blade 1, the vibration level increases as the mass increases. However, the vibration level decreases on Blade 2 when the mass increases. Consequently, calculations have found that adding 2.4 g of mass at Blade 1

resulted in better response. The mass added is constant as one washer is equal to 2.4 g. Four washers have been added individually on Blade 1, but since the vibration level increased thereafter, no more mass was added after the fourth washer.

A washer weighing 3.6 g was then added to Blade 2 after the fourth washer showed a decrease in vibration level. Essentially, it is assumed that the vibration keeps decreasing if more masses are added.

The green reference line (without mass) shows that the tail rotor actually vibrates more without any mass added whereas more weight needs to be added to Blade 2. The vibration level will decrease as the mass added increases. Thus, more mass needs to be added to Blade 2 instead of Blade 1.

Figure 18 shows the difference in peak values of vibration for 2.4 g and 9.6 g of mass added to Blade 1 and Blade 2 respectively. The vibration level in Blade 1 is much higher than Blade 2. It means that more vibration occurs if mass is added at Blade 1 and vice versa. It has been found that, it is better to put one washer at Blade 1 rather than no mass added, but still, adding one washer at Blade 2 had lowered the vibration level. So, instead of adding one washer at Blade 1, a washer was added to Blade 2.

Improper track and balance of the tail rotor blades is a major contributor to vibration. Unbalanced assembly during installation of the tail rotor into the boom may perhaps be a cause for this problem. Unbalanced assembly may occur owing to the inability to locate the center point of rotation. This occurs when the centerline of the shaft does not correspond with the mass centerline. This incorrect installation can be a reason why the blades experience vibration in a different way. Uneven mass on each blades also contribute towards the static imbalance as the

center of gravity of the rotor hub slightly shifts towards the heavier blade. It is important to make the tail rotor statically balanced at first. Statically imbalance can be corrected using a single mass. Along the shaft in the tail boom, there is no bearing. The absence of bearing along the shaft may contribute to the occurrence of vibration.

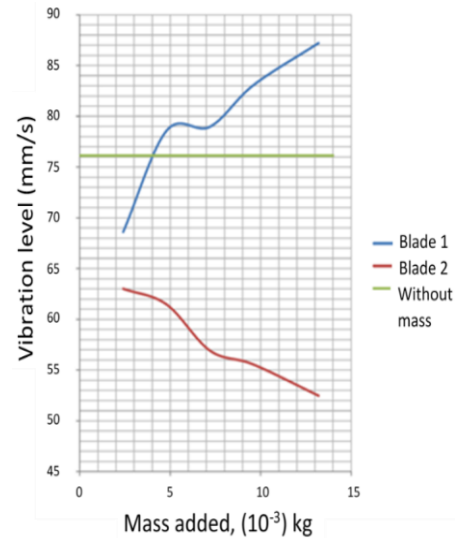

Figure 17 Graph of vibration level vs mass addition.

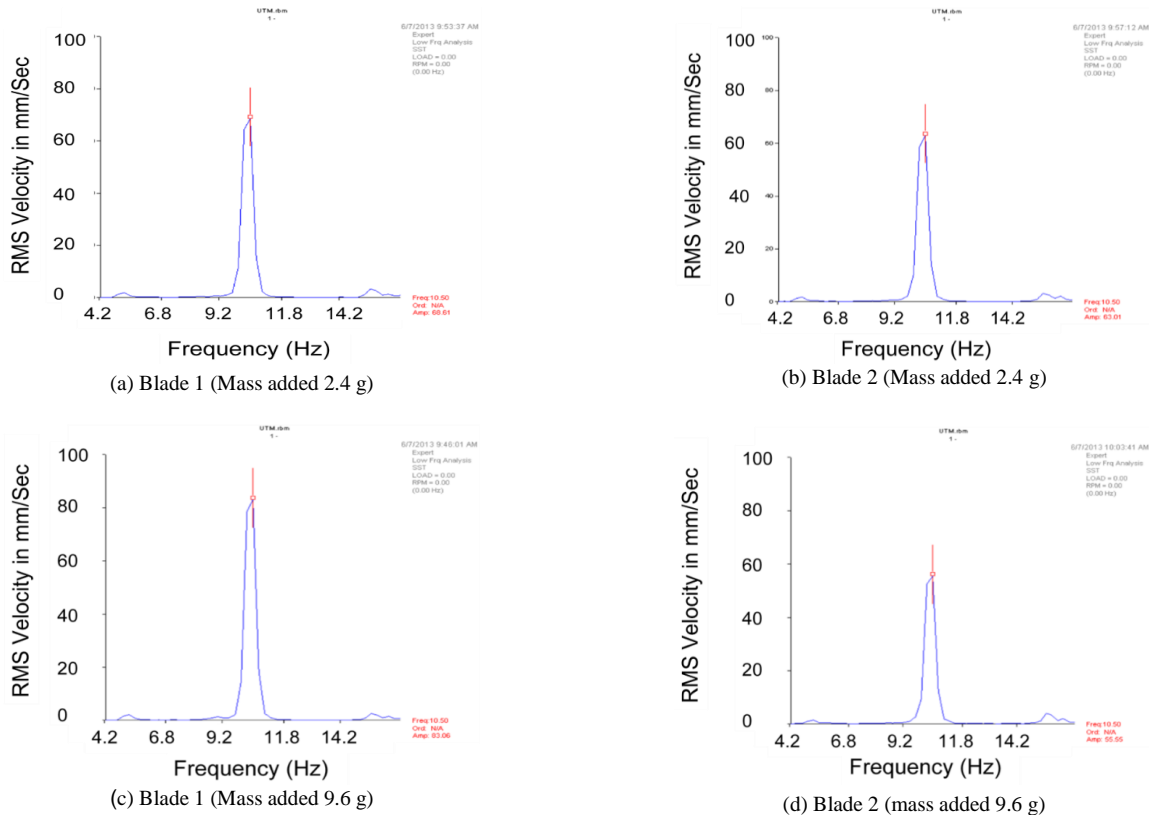

Figure 18 Vibration peak amplitudes for different balancing mass addition to the blades

#### ■4.0 CONCLUSION

Helicopter tail rotor is important to counter the torque effects generated by the main rotor. Consequently, it is important to balance the tail rotor as discrepancies in balancing the tail rotor would lead to vibrations in the entire helicopter. Though there will always be a certain amount of vibration remaining in the helicopter, it is essential to reduce the vibration to a minimum. This research concentrates on balancing the tail rotor of the UTM Single-Seat Helicopter. Adding masses to the blades has significantly decreased the vibration level. Blade 2 requires more added mass as the addition of more mass on this blade reduces the vibration level. One washer was added on Blade 1 where the results obtained were acceptable as the vibration level was found to be lower than the vibration level without any mass added. Masses can also be added on both blades but addition in the second blade has to be more than the addition of mass in the first blade. It is crucial to locate the center of rotation of the shaft and other rotating parts as it plays an important role in vibration. Some crucial facts have been identified during this research, one of which is improper track and balance of the tail rotor blades may lead to vibration during flying. Nevertheless, there is always a certain amount of vibration left in the helicopter rotor systems as there are many rotating parts in the helicopter. When the vibrations reach an abnormal level, then the rotor system needs to be checked and balanced so as to reduce the vibration.

#### Acknowledgement

The authors would like to thank Universiti Teknologi Malaysia for providing valuable support to conduct this research project Vot. Number Q.J130000.2424.00G66..

#### References

- [1] Z.B.A. Awal, M.S.B. Ammoo and N.S.B. Jamaluddin. 2014. The Effect of Rotor Disc Clearance on the Lift Performance of Contra-Rotating Rotor Blades. *International Journal of Research in Engineering and Technology*. 3(5): 739–745.
- [2] M.S.B. Ammoo and Z.B.A. Awal. 2013. Main Rotor Blade Air Flow Characteristics & Behaviour of a Remote Controlled Sub-scale Helicopter: A Case Study, *International Journal of Research in Aeronautical and Mechanical Engineering*. 1(7): 228–235.
- [3] Z.B.A. Awal and M.S.B. Ammoo. 2014. A Case Study on the Air Flow Characteristics of the Hirobo-FALCON 505 Controllable Helicopter's Main Rotor Blade. *Applied Mechanics and Materials*. 527: 39–42.
- [4] M.S.B. Ammoo and Z.B.A. Awal. 2014. An Investigation on Crack Alleviation in Bending of Aluminium 2024 for Aircraft Applications. *International Journal of Research in Aeronautical and Mechanical Engineering*, 2(3): 255–269.
- [5] D.L. Kunz and M.C. Newkirk. 2009. A Generalized Dynamic Balancing for the AH-64 Tail Rotor, *Journal of Sound and Vibration*. 326: 353–366.
- [6] J.G. Helmuth and J.R. Chadwick. 1974. *Helicopter Rotor Balancing Method and System*. Chadwick-Helmuth Electronics, Inc. Monrovia. Calif. Appl. 298: 397.
- [7] R. Ferrer, T. Krysinski, S. Bellizzi and P.A. Aubourg. 2001. New Methods for Rotor Tracking and Balance Tuning and Defect Detection Applied to Eurocopter Products. *Proceedings American Helicopter Society. 57<sup>th</sup> Annual Forum*. 2: 1128–1136.
- [8] H.P. Bloch and F.K. Geitner. 2005. Machinery Component Maintenance and Repair, *Practical Machinery Management for Process Plants*. 3: 258–366.
- [9] J.W. Lund and J. Tonnesen. 1972. Analyses and Experiments on Multiplane Balancing of a Flexible Rotor. *American Society of Mechanical Engineers Journal of Engineering for Industry*. 94: 233–242.
- [10] Y. Kang, M.H. Tseng, S.M. Wang, C.P. Chiang and C.C. Wang. 2003. An Accuracy Improvement for Balancing Crankshafts. *Mechanism and Machine Theory*. 38(12): 1449–1467.
- [11] F. Seve, M.A. Andrianoely, A. Berlioz, R. Dufour and M. Charreyron. 2003. Balancing of machinery with a flexible variable-speed rotor. *Journal of Sound and Vibration*, 264: 287–302.
- [12] S. Zhou and J. Shi. 2001. Active Balancing and Vibration Control of Rotating Machinery: A Survey. *The Shock and Vibration Digest*. 33(4): 361–371.
- [13] M. MacCamhaoil. Static and Dynamic Balancing of Rigid Rotors. Bruel & Kjaer application notes, BO 0276-12, Web link: <http://www.bksv.com/doc/BO0276.pdf>