

# Modelling and Simulation of Boost Converter with Maximum Power Point Tracking (MPPT) for Photovoltaic Application

Ahmad Shaharuddin Mat Su, Rasli Abd Ghani, Slamet

Malaysia-Japan International Institute of Technology (MJIIT), Universiti Teknologi Malaysia, Jalan Semarak, Kuala Lumpur, Malaysia

\*Corresponding author: rasli.kl@utm.my

## Article history

Received : 31 July 2014  
 Received in revised form :  
 23 November 2014  
 Accepted : 1 December 2014

## Graphical abstract

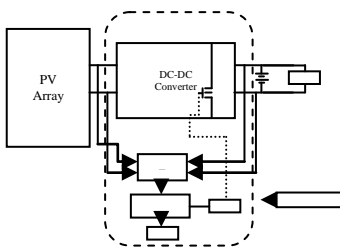

## Abstract

This paper presents the proposed model and simulation of a DC to DC converter with maximum power point tracking (MPPT) using fuzzy logic controller (FLC) for a standalone Photovoltaic (PV) System. This research will focus on the developing high performance DC to DC converter with fuzzy logic controller based to extract the maximum power that generated by the PV panel. The system composed of the PV array and DC-DC boost converter with MPPT system. The maximum power point tracking control is based on adaptive fuzzy logic to control ON/OFF time of IGBT switch of DC-DC boost converter. The proposed DC to DC converter is designed by using the Multisim software while the controller programme will be carried out by using the Matlab Simulink software. Pulse width modulation will be generated by the controller to trigger the IGBT gate. The performance of the proposed model is evaluated by the simulation and the result show that our proposed converter can convert more power from generated voltage. By using the fuzzy logic method to track the maximum power of the PV array, it is faster and the voltage is stable.

**Keywords:** Photovoltaic (PV); DC-DC boost converter; Maximum power point tracking (MPPT); Fuzzy logic; Pulse width modulation (PWM)

## Abstrak

Kertas kerja ini membentangkan cadangan model dan simulasi DC ke DC penukar dengan pengesanan titik maximum kuasa (MPPT) menggunakan pengawal logik kabur (FLC) untuk Photovoltaic (PV) Sistem. Kajian ini akan memberi tumpuan kepada pembangunan DC ke DC penukar yang berprestasi tinggi berasaskan pengawal logik kabur untuk mengambil kuasa maksimum yang dihasilkan oleh panel PV. Sistem terdiri daripada Photovoltaic (PV) dan DC ke DC penukar dengan sistem MPPT. Titik kuasa maksimum kawalan pengesanan adalah berdasarkan kepada logik kabur adaptif untuk mengawal masa ON / OFF suis IGBT dalam litar DC ke DC penukar. Cadangan litar DC ke DC penukar direka dengan menggunakan perisian Multisim manakala program pengawalan akan dilakukan dengan menggunakan perisian Matlab Simulink. Pulse modulasi lebar akan dihasilkan oleh pengawal untuk mencetuskan gerbang IGBT. Prestasi model yang dicadangkan dinilai oleh simulasi dan hasil menunjukkan cadangan litar DC ke DC penukar menukarkan lebih banyak kuasa daripada voltan yang dihasilkan. Dengan menggunakan kaedah logik kabur untuk mengesan kuasa maksimum PV sistem, ianya lebih cepat dan voltan yang dihasilkan yang stabil.

**Kata kunci:** Photovoltaic (PV); DC-DC penukar meningkatkan; pengesanan titik kuasa maksimum (MPPT); logik kabur; Pulse modulasi lebar (PWM)

© 2012 Penerbit UTM Press. All rights reserved.

## 1.0 INTRODUCTION

Energy is very important for our daily life routine. Most of energy resources are use come from earth. These resources can be classified into three types which are very dangerous resource, unlimited but less efficient resource and limited resource. Nowadays, many people seeking for green and unlimited energy resource. The most effective, reliable and harmless energy source is probably solar energy. Solar energy is harvest by using photovoltaic (PV) system<sup>1</sup>.

However, the solar resources is a natural resources which is not stable in location, time, season, and weather and its installation cost is comparatively high. The long term running cost for photovoltaic system to harvest the energy from the solar is lower regardless of the high initial cost. Since PV sources exhibit nonlinear v-i characteristics, their power output mainly depends on the nature of the connected load. Hence, direct load connections to PV systems result in poor overall efficiency. As solar energy is such a convenience and robust source of energy as well as the high initial cost, it would be wise if we could design a

high efficient PV system to minimize the cost of their cycle. An important consideration to increase the efficiency of the PV system is to obtain the approximately maximum power of the PV system by operating the system near to its maximum power point (MPP).

However, maximum power point of PV system is always changing with irradiation and temperature and this makes the power point tracking is a complicated problem. To overcome this problem, a MPPT controller is needed to generate the pulse width modulation (PWM) signal which is control a specific duty cycle to trigger the switching gate of the DC-DC boost converter in order to locate the nearest maximum power point of the PV system.

To obtain higher power output, a high step up and soft switching boost converter is designed to improve the performance of the PV system. Boost converter is one of the important devices which are acts as the front end power electronic device for a PV system. The conventional converter has a hard switching where the efficiency is reducing when the voltages or currents in the semiconductor components change significantly from high to low or vice versa<sup>2-6</sup>.

This paper presents an efficient MPPT controller for PV systems by incorporating a new model of high step up boost converter with fuzzy logic based rules for tracking the maximum power that generated by the PV array. The proposed model converter is designed by implementing passive snubber to minimize the losses in the switching and improve efficiency of the converter. For tracking the maximum power of the PV array, a closed loop fuzzy logic based will apply to the system.

**2.0 IMPLEMENTATION OF FUZZY LOGIC METHOD**

Fuzzy logic controllers have the advantages of working with imprecise inputs, not needed an accurate mathematical model, and handling nonlinearity<sup>1</sup>. The inputs are normally an error *E* and a change of  $\Delta E$  as given in (1) and (2) respectively.

$$E(n) = \frac{P(n) - P(n-1)}{V(n) - V(n-1)} \tag{1}$$

$$\Delta E(n) = E(n) - E(n - 1) \tag{2}$$

*E* and  $\Delta E$  are calculated and converted to the linguistic variables during fuzzification. Linguistic variables are non-precise variables that often convey a surprising amount of information. To simplify the control calculation, the values of error *E* and change of error  $\Delta E$  can be normalized as (3) before fuzzification process.

$$Y_s = \begin{cases} -1, Y < -Y^* \\ \frac{Y}{Y^*}, |Y| < Y^* \\ 1, Y > Y^* \end{cases} \tag{3}$$

Where  $Y^* = Y_{max}$ , so the scopes of error *E* and change of error  $\Delta E$  will be [-1,1].

The fuzzy logic output is typically a change in duty ratio  $\Delta D$  of the power converter. The linguistic variables assigned to  $\Delta D$  for the different combinations of *E* and  $\Delta E$  as shown in (Tab. 1) which is based on a boost converter. If for example, the input is *E* is PB, and  $\Delta E$  is ZE, then we want to largely increase the output which is duty ratio, that is  $\Delta D$  should be PB to reach the MPP.

**Table 1** Fuzzy Rule Base

$\Delta E \backslash E$	NB	NS	ZE	PS	PB
NB	ZE	ZE	NB	NB	NB
NS	ZE	ZE	NS	NS	NS
ZE	NS	ZE	ZE	ZE	PS
PS	PS	PS	PS	ZE	ZE
PB	PB	PB	PB	ZE	ZE

The final step is to combine the fuzzy output into a crisp system output. The result of the defuzzification has to be numeric value which determines the change of duty cycle of the PWM signal to drive the IGBT gate. There are various methods to calculate the crisp output of the system. Centre of Gravity (COG) method is used due to better result it gives. The COG can be expressed mathematically as (4).

$$\Delta D = \frac{\sum_{i=1}^4 Y[i] \times F[i]}{\sum_{i=1}^4 Y[i]} \tag{4}$$

Where *Y*[*i*] is the *i*<sup>th</sup> members of the output vector and *F*[*i*] is the multiplying coefficient of the output membership function as shown in (Tab. 1), and  $\Delta D$  is the change of duty cycle. The  $\Delta D$  represents a signed number which is added or subtracted from the present duty cycle to generate the next system response for reaching the MPP.

**3.0 EXPERIMENTAL**

The schematic diagram for the MPPT controller for the PV system showed in (Fig.1). It consists of a PV panel, DC-DC boost converter, Controller and DC output load. The boost converter is the front-end power electronic device for the PV system. It is the middle part between the PV panel and the load. It was a DC-DC converter with output voltage greater than the input voltage. It is combination of a switching mode power supply which is contain at least a switching component, an inductor as an energy storage component, an output rectifier diode and a filter capacitor element. Filter made of capacitor in combination with inductor are normally used to reduce the voltage ripple at the output voltage. The main problem in the converter is degradation during conversion cause by an inherent problem which is reverse recovery problem occur. Improvement in the converter design is made to improve the conversion efficiency.

(Fig. 2) show the proposed high step up boost converter design topology. This topology is to introduce the soft switching boost converter. The components of the converter are DC capacitor input filter from PV panel, a coupled inductor at the primary side (*L*<sub>1</sub>), inductor at the secondary side (*L*<sub>2</sub>), connecting capacitor (*C*<sub>6</sub>), a switching device comprising of an IGBT (*Q*<sub>1</sub>) with diode (*D*<sub>1</sub>), an active regenerative snubber circuit, and output resistor (*R*<sub>1</sub>). The circuit of active regenerative snubber consists of input diodes (*D*<sub>2</sub>) and (*D*<sub>3</sub>), an input capacitor, a snubber inductor (*L*<sub>3</sub>), a switching device (*Q*<sub>2</sub>) with diode (*D*<sub>4</sub>), a rectifier diode (*D*<sub>7</sub>), a snubber output capacitor (*C*<sub>3</sub>) and a passive snubber contains a capacitor (*C*<sub>2</sub>) and diodes (*D*<sub>6</sub>) and (*D*<sub>7</sub>). The coupled inductor in the proposed boost converter can be regarded as an ideal transformer with turns ratio (*n*) and coupling coefficient (*k*). The turn ratio, coupling coefficient and the voltage gain (*G*) of the proposed converter are given as;

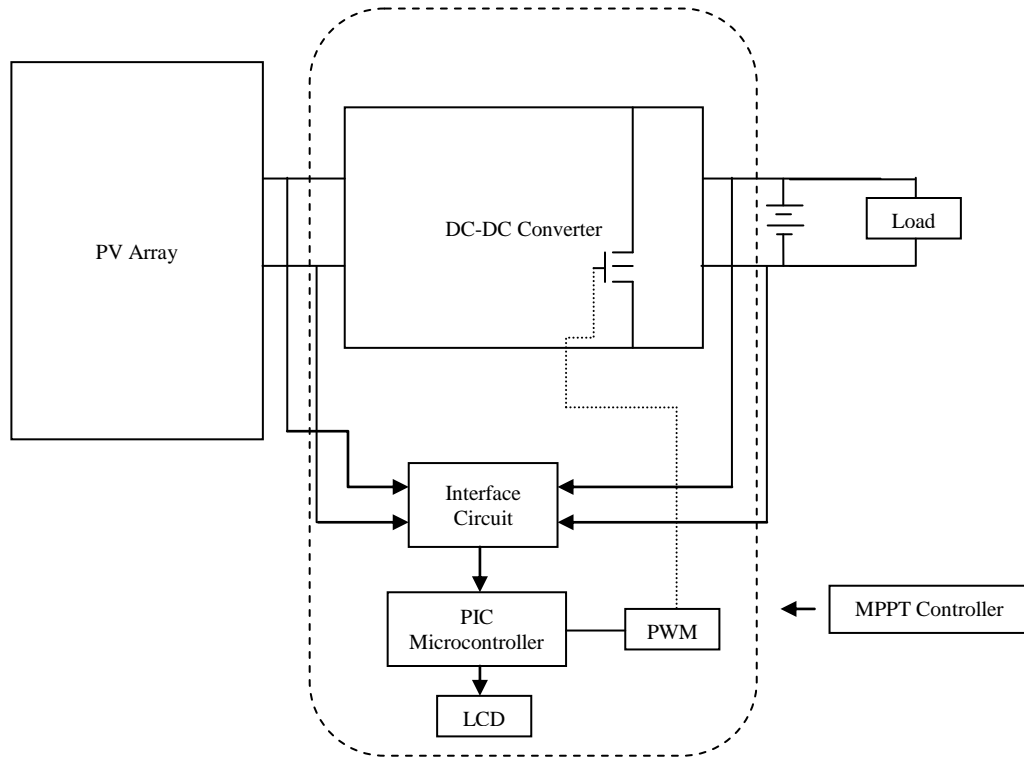

Figure 1 Schematic diagram of the MPPT Controller for PV System

$$n = \frac{N_2}{N_1} = \frac{N_{L2}}{N_{Lm}} \quad (5)$$

$$k = \frac{L_m}{(L_k + L_m)} \quad (6)$$

$$G = \frac{V_o}{V_{in}} = nk + \frac{1 + Dnk}{1 - D} + \frac{1}{(1 - D)^2} \quad (7)$$

where D denotes the duty cycle of the triggering of the switching,  $V_{in}$  and  $V_o$  are the input and output voltages respectively.

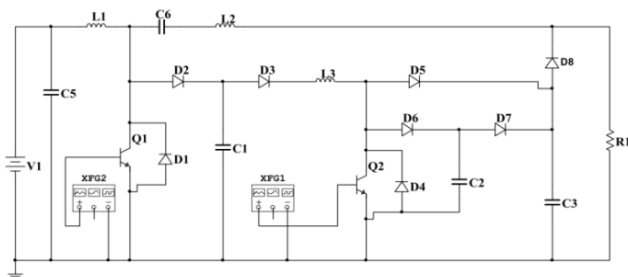

Figure 2 Proposed High Step-up Boost Converter

The main components in the fuzzy logic based MPPT controller are fuzzification, rule-base, inference and defuzzification as shown in the (fig. 3). The variable input is PV array power and

change in current and the output is step change of converter current reference. This output is the reference current that drawn from the PV array to the boost converter.

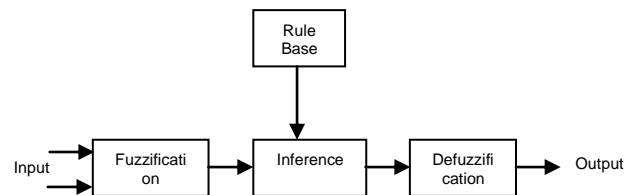

Figure 3 Main components in fuzzy logic

#### 4.0 RESULTS AND DISCUSSION

The performance of the boost converter was evaluated based on the simulation by considering input voltage,  $V_{in} = 30V$  and duty cycle,  $D = 0.3$  with frequency,  $f = 50kHz$ . Figure 4 shows the output voltage of the proposed boost converter obtained from the simulation using Multisim software. From the figure, it can be seen that the output voltage of the proposed boost converter is 44.54 V with a very stable output voltage. The converter converts about 48 % of generated voltage from input voltage.

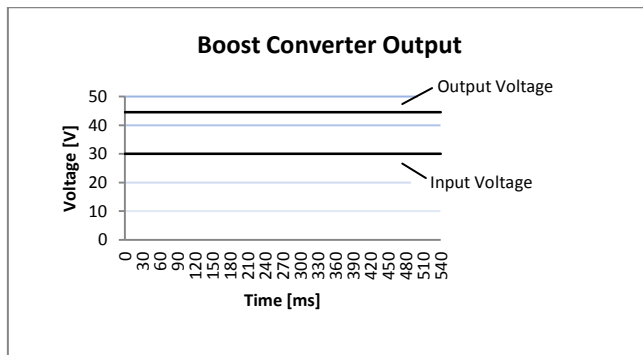

Figure 4 Proposed DC-DC converter output

## 5.0 CONCLUSION

The design and simulation of a boost converter with fuzzy logic based MPPT controller for a PV system has been presented. The proposed boost converter circuit is first designed using the multisim based computer simulation. The simulation results of the boost converter showed that the proposed boost converter produces a stable step-up DC output voltage. Developments on the boost converter circuit need to be done to improve the conversion of the output voltage.

## Acknowledgement

The author would like to express my appreciation for the support from my supervisor in my research.

## References

- [1] S.A. Khan, M.I. Hossain. 2010. Design and Implementation of Microcontroller Based Fuzzy Logic Control for Maximum Power Point Tracking of a Photovoltaic System. *6th International Conference on Electrical and Computer Engineering ICECE*.
- [2] Subiyanto, Azah Mohamed, M.A Hannan. 2010. Hardware Implementation of Fuzzy Logic based Maximum Power Point Tracking Controller for PV Systems. *4<sup>th</sup> International Power Engineering and Optimization Conf.*
- [3] Subiyanto, Azah Mohamed, M.A Hannan.2011. Development of an Efficient Photovoltaic Maximum Power Point Tracking Controller. *IEEE International Electric Machines & Drives Conference (IEMDC)*.
- [4] Subiyanto, A. Mohamed, M.A. Hannan.2009. Maximum Power Point Tracking in Grid Connected PV System Using A Novel Fuzzy Logic Controller. *IEEE Student Conference on Research and Development (SCoReD 2009)*.
- [5] M. Miyatake, M. Veerachary, F. Toriumi, N. Fujii, H. Ko. 2011. Maximum Power Point Tracking of Multiple Photovoltaic Arrays: A PSO Approach. *IEEE Transactions on Aerospace and Electronic System*. 47(1): 367.
- [6] J.L. Santos, F. Antunes, A. Chebab, C. Cruz. 2006. A maximum power point tracker for PV systems using a high performance boost converter. *Solar Energy* 80: 772–778.