

## HARDWARE DESIGN AND INTERFACING OF A ROBOT ASSISTED SUBTRACTIVE PROTOTYPING SYSTEM

TANG SAI HONG<sup>1</sup>, WONG SU LUAN<sup>2</sup>, PAUL YOUNG<sup>3</sup>, SHAMSUDDIN SULAIMAN<sup>4</sup> & M. S. J. HASHMI<sup>5</sup>

**Abstract.** The paper discusses about the issues of hardware design and interfacing of a self-developed robot assisted subtractive prototyping system. A four degrees of freedom robotic manipulator was driven by four alternative current (a.c.) brushless servomotors, which were controlled by separate drives. The drives received direction and distance signals from an indexer, which in turn was controlled by a user-developed software through a high specification personal computer (PC). The manipulator was used to hold and manipulate the model material (polystyrene) for ball nosed end milling process. The interfacing problem with a high-end PC has been rectified and all the manipulator axes moved synchronously. System has been tested for producing three-dimensional complex shaped model and the result was satisfactory. Generally, the system is effective, space and time saving, and can accomplish the entire computer aided design and manufacturing tasks.

*Keywords:* Manipulator, interfacing, prototyping, manufacturing

**Abstrak.** Kertas kerja ini membincangkan isu yang timbul dari segi reka bentuk perkakasan dan antara muka untuk sebuah sistem prototaip pengurangan yang dibangunkan oleh penyelidik. Suatu robot pengolah yang mempunyai empat darjah kebebasan digerakkan oleh empat motor servo arus ulang-alik yang tidak berbers. Motor tersebut dikawal oleh pemacu yang berasingan. Pemacu menerima isyarat arah dan jarak dari pengindeks. Pengindeks dikawal oleh perisian yang dibangunkan oleh penyelidik melalui sebuah komputer peribadi yang berspesifikasi tinggi. Pengolah digunakan untuk memegang dan mengolah suatu blok polistairin untuk proses pengisaran. Masalah di antara antara muka dengan komputer peribadi dapat diselesaikan dan semua paksi pengolah bergerak dan berhenti dalam masa yang sama. Sistem telah diuji untuk mengeluarkan model tiga dimensi yang berupa kompleks. Keputusan pengisaran adalah memuaskan. Secara umumnya, sistem itu adalah berkesan, menjimatkan masa dan tempat, dan dapat melaksanakan semua kerja reka bentuk dan pembuatan bantuan komputer.

*Kata kunci:* Pengolah, antara muka, prototaip, pembuatan

<sup>1,4&5</sup> Department of Mechanical & Manufacturing Engineering, Faculty of Engineering, Universiti Putra Malaysia, 43400 UPM Serdang, Selangor.

<sup>2</sup> Faculty of Educational Studies, Universiti Putra Malaysia.

<sup>3</sup> School of Mechanical & Manufacturing Engineering, Faculty of Engineering & Design, Dublin City University.

<sup>1</sup> Corresponding author. Tel: ++60389466332. Fax: ++60386567099. E-mail: saihong@eng.upm.edu.my

## 1.0 INTRODUCTION

At present, there are two important challenges in product manufacturing industry. One of them is to find a better way in reducing the product development time substantially. Another challenge is the improvement of flexibility for manufacturing small batch size products and varieties of products [1]. If the product development time is shorter, the lead-time to market will be reduced. Subsequently, a manufacturer can grab a bigger market share.

In fact, more than 70 percent of senior management staff, rate the lead-time to market as one of the most important criterias that drive them in the businesses. Thus, the key to success for most manufacturers is the capability to provide quality products to market, at the shortest possible lead-time with the right cost [2]. Besides, the gradual shift from mass production to customised production for satisfying a growing number of 'niche markets' has also pushed for the reduced time to market [3].

One way of having a shorter time to market a product is to reduce the prototyping time. Prototyping has been one of the essential processes in the design and manufacturing cycle. Most of the time, a conceptual design has to be developed into a physical product so that the designers and engineers can rate its aesthetic features, validate its functionality, check for specifications conformance, and test its performance.

There are two ways in reducing prototyping time, namely developing new prototyping technologies and improving the existing conventional technologies. Both ways will need computer to control the processing operations and produce complex shaped components. In fact, computer controlled methods are slowly replacing most of the conventional methods [4]. Besides, computers are used because they are able to represent objects in a three-dimensional co-ordinate system [5].

One way of reducing prototyping time is to develop new prototyping technologies like stereolithography apparatus, selective laser sintering, or fused deposition modelling [6]. These methods are categorised under the additive prototyping processes. Another method is to improve the principal existing technique like integrating a precision robotic manipulator into a conventional machining process like milling, with the aid of computer-aided design software/computer-aided manufacture program. The improved system will save as much as 40 percent of the floor space with the same size of workspace [7]. The second method is considered as a subtractive prototyping process and it is the main focus of the present study.

One of the related subtractive prototyping studies was done by using a commercial industrial robot as a material removal tool for producing prototypes [8]. However, the cost of a commercial robotic system is too expensive. Another related study was done using a computer to control a robotic manipulator for the manufacturing of complex shaped dies [9]. Unfortunately, the system was too slow and its capability was limited in terms of the type of software that can be incorporated into the system. Hence, the objective of this study is to look at ways in developing a cheaper and faster system that can accommodate more softwares so that a stand alone complete system can be achieved.

## 2.0 ROBOT ASSISTED SUBRACTIVE PROTOTYPING SYSTEM

The whole system consists of a personal computer, indexers, drives, a.c. brushless servomotors, a four degrees of freedom precision robotic manipulator, and a ball nosed end milling equipment. The personal computer is used to control the system by sending commands and receiving responses from the indexer. The indexer will in turn communicate with the drives which control the a.c. brushless servomotors. The a.c. brushless servomotors will drive a four degrees of freedom precision robotic manipulator. The manipulator will feed the work material (a polystyrene cylindrical block) to the ball nosed cutter for milling three-dimensional complex shaped objects.

### 2.1 Robotic Manipulator

The manipulator is illustrated in Figure 1. In the diagram, the plan and side views of the manipulator are shown. The length of the manipulator is 1270 mm. Its width and height are 616 mm and 440 mm respectively. The four degrees of freedom are  $y$  linear motion axis,  $x$  linear motion axis, roll (rotation around  $y$ -axis), and pitch (rotation around  $x$ -axis). The direction of motion for each motion axis are also shown in the figure.

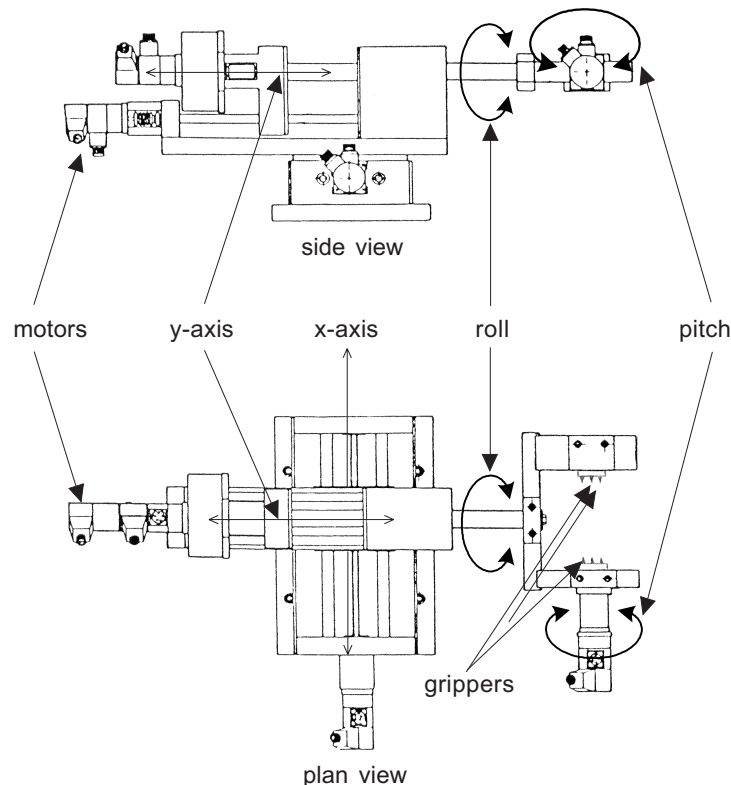

**Figure 1** Side and plan view of the manipulator

The weight of the manipulator is about 55 kg. Aluminum alloy (BS HE30 TF) that has the tensile strength of  $280 \text{ MN/m}^2$  was used to manufacture the main parts of the manipulator. The diameters of the steel shafts used are 16 mm, 20 mm, and 30 mm, having a hardness of 60 HRC.

The manipulation unit around  $x$ -axis (pitch) consists of an a.c. brushless servomotor, a harmonic drive gearbox and a pair of three-pin grippers. The range of the work piece size that can be held by the grippers is 120 to 125 mm in length and 40 to 150 mm in diameter. An a.c. brushless servomotor in conjunction with a harmonic drive gearbox, having a gear ratio of 100:1 are used to drive the grippers. The motor resolution is set at 5000 steps per revolution. The motor for the pitch manipulation can travel an angular distance of 0.00072 degrees per full motor step.

The manipulation unit along  $y$ -axis consists of an a.c. brushless servomotor, a coupling, a lead screw with a pitch of 1.5 mm, and two 16 mm diameter steel shafts. An a.c. brushless servomotor drives this unit. The lead screw is connected to the motor shaft by means of a flexible coupling. The steel shafts are used for ensuring that the motion is straight and support the manipulation unit around the  $y$ -axis (roll). The motor resolution is set at 5000 steps per revolution. The motor can travel a linear distance of 0.0003 per full motor step. Total linear distance that can be travelled by the unit is 130 mm.

The manipulation unit around  $y$ -axis (roll) is directly located above the manipulation unit along the  $y$ -axis. It consists of an a.c. brushless servomotor, a gearbox, a coupling, and a 30 mm diameter steel shaft. An a.c. brushless servomotor in conjunction with a gear box, having a gear ratio of 18:1, generated the roll motion around  $y$ -axis. The gear box is attached to a 30 mm diameter steel shaft by a rigid coupling. The motor resolution is set at 5000 steps per revolution. The motor for roll motion can travel an angular distance of 0.004 degrees per full motor step. At the end of the steel shaft is the manipulation unit around  $x$ -axis (pitch).

The manipulation unit along  $x$ -axis consists of an a.c. brushless servomotor, a coupling, a lead screw with a pitch of 1.5 mm, and a pair of 20 mm diameter steel shafts. The a.c. brushless servomotor is connected to the lead screw through the flexible coupling. The steel shafts are for supporting the manipulation unit around  $x$ -axis as well as the units along, and around  $y$ -axis. They are also for ensuring straight motion. The maximum distance of 240 mm can be travelled by this manoeuvring part along  $x$ -axis. The motor is set at 5000 steps per revolution. The motor can travel a minimum linear distance of 0.0003 mm per full motor step.

## 2.2 Interfacing

One of the primary components in producing three-dimensional complex shaped product from the robot assisted subtractive prototyping system is the interface system. The interface system consists of an indexer, drives, and a.c. brushless servomotors.

They are located between the personal computer and the precision manipulator. Figure 2 illustrates the schematic diagram of the interface system, where the system is bounded by the thickest dotted line.

As shown in Figure 2, a personal computer is used to send commands and receive responses from an indexer. The indexer in turn communicates with the three drives. The drives control three a.c. brushless servomotors that drive the precision robotic manipulator to produce the three-dimensional complex shaped object. For functional purposes, two external power supply modules are needed for the indexer and the three drives. The drives' performances can be tuned from the personal computer via the RS-232 link.

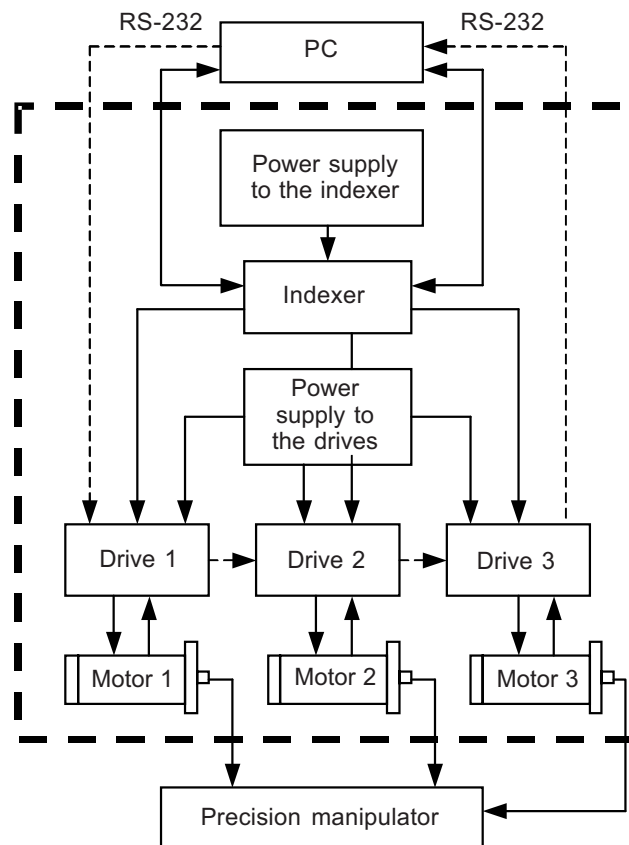

**Figure 2** Interface system

### 2.2.1 Indexer

An indexer uses a 16-bit microprocessor for controlling the motion of up to three motor axes, independently or simultaneously. The indexer is used with an IBM microcomputer (PC, XT or AT) or compatible, and is suitable for any kind of drive

systems that can accept pulsed control signals. It is used for controlling velocity, distance, and linear acceleration parameters.

The indexer receives acceleration, velocity, position, and direction information in ASCII (American Standard Code for Information Interchange) characters from the personal computer's control program, and uses that information to produce motion profile command signals for the drive system. The drive commands are in the form of "step" pulses. They can be issued at controlled rates of up to 500 000 steps per second to the drive system. The indexer system is illustrated in Figure 3.

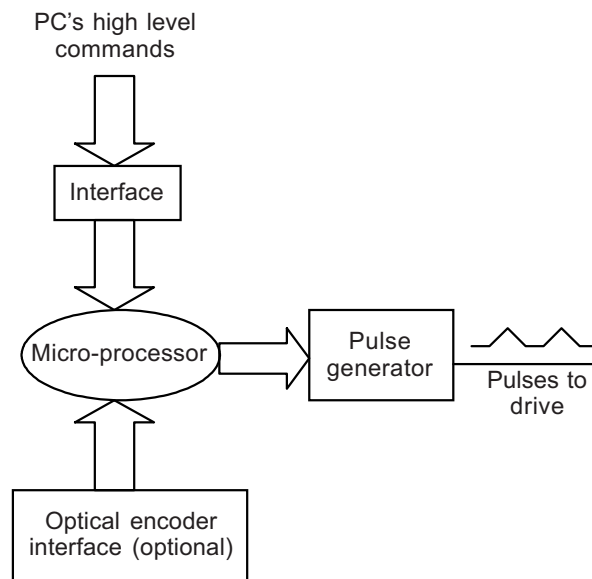

**Figure 3** Indexer system

The indexer commands enable the precision control of motor rotation for up to three axes, independently or simultaneously. These motors can be controlled to rotate to a certain precise position and stop, rotate at a constant velocity and/or accelerate, alternate back and forth between two angular positions, or use a sequential combination of such moves.

The indexer consists of two parts, which are a main circuit board and an adaptor box. The main circuit board is incorporated with the personal computer (PC) via ISA slot in the motherboard. The cable harness with four flat cable connectors from the adaptor box which run through the slot in the PC's access panel and plugged into the main circuit board. The adaptor box is external to the PC and connects to the drives.

In order to communicate with the indexer, the PC must know where to write instructions and read responses (will be explained in the next section). Hence, the indexer must have an address that does not conflict with typical devices that reside on the PC's I/O bus such as graphic adaptors, disk drives, and other peripheral devices. The address can be set to any number that the PC will recognise as valid.

### 2.2.1.1 PROGRAMMING OF INDEXER

Any programming language can be used to program the indexer's operations. For this paper, C language is used to program the indexer's operations. The motion control program only needs to have the capabilities of reading information from and writing digital data to the I/O bus of the PC. Motion control commands and responses are transferred through the Input Data Buffer (IDB) and Output Data Buffer (ODB). Interface control commands and status information are transferred through the Control Byte (CB) and Status Byte (SB).

ODB and SB are read-only registers, whereas IDB and CB are write-only registers. Indexer commands consist of "string" or sequences of ASCII. A register or buffer is a temporary storage area for holding only one character (one 8-bit "byte") at any occasion. Thus, passing a command to the indexer means transferring each character in the command one at a time.

Each character transfer requires that the sender notifies the receiver that a character is ready, and that the receiver notifies the sender that the character has been received. The notification process involves the 8-bit CB and SB registers. Each bit is a "flag" with a specific meaning. The CB will allow certain operating conditions to be set and the SB will report the others. Signaling the indexer involves setting or clearing (resetting) the control bits or flags, which means forcing them to a binary value of one or zero, respectively.

### 2.2.1.2 MOTION CONTROL OF THE INDEXER

All applications of an indexer axis are either movement of a motor to a precise position (number of motor steps) or movement of a motor at a prescribed velocity (steps per second). Output control for both position and velocity can be achieved with a high degree of precision, without any additional external feedback. There are approximately 106 commands for specifying different conditions and operating modes within the motion control program. Better motion control and responses from the indexer lie in the selection of suitable commands for any particular set of motion sequence.

The standard motor resolution setting for all the axes on the indexer is 25 000 steps per revolution although it supports motor or drive resolutions for up to 50 000 steps per revolution. The drives for motors are configured in the range of 1000 to 16 384 steps per revolution. For accurate speed control, each indexer axis needs to know the resolution of its controlled motor, while the settings of the motor resolution on the drives and the indexer must match. In this project, the drives and indexer motor resolution settings are kept at 5000 steps per revolution.

In the current operation mode, the indexer will drive the motor to a desired position, at a specified velocity. It can be divided as incremental mode and absolute mode. In the incremental mode, all move distances are referenced to the starting position of

each move. In the absolute mode, all move distances are referenced to the absolute zero position (home position). The incremental mode is used in the project due to the nature of the motion control program.

### 2.2.2 Drive

The second part of the interface system is the drive. It is a complete brushless servo positioning system. The system consists of a brushless servomotor, a brushless resolver feedback, and a microprocessor based closed loop drive amplifier. The drive accepts digital step and direction inputs from the indexer for controlling the position and velocity. The onboard microprocessor monitors both the pulse inputs from the indexer and the resolver feedback from the a.c. brushless servomotor. Then, it will determine the proper current level to apply to the motor.

Closed loop performance is simplified by the control of a microprocessor and a sophisticated servo algorithm. All servo performance parameters are stored in non-volatile EEPROM memory. Hence, a conventional system analogue potentiometer is not needed for adjustment purposes. The power amplifier section of the drive utilises a MOSFET 20 kHz pulse width modulation (PWM) current control. This design will improve the low speed smoothness, resulting in quiet operation.

#### 2.2.2.1 SERVO SYSTEM OF THE DRIVE

The drive can be divided as digital controller board and analogue amplifier board. The controller board sends two digitised waveforms from its DAC (digital to analogue converter) to the analogue amplifier board. These waveforms represent two commanded motor phase currents. The analogue amplifier board generates its own third phase command and measures the actual motor current to determine the correct pulse width of voltage to apply to the motor windings. The drive servo system is shown in Figure 4.

The controller will command a “desired current” to the amplifier board. Then, the amplifier board will attempt to generate that “desired current” in the motor windings. The resolver that is attached to the motor will sense the position of the motor shaft and send the information back to the controller. With the positional information, the controller will generate the “desired current” command to the amplifiers.

The generation of the current command to the amplifier by the controller is based on several quantities. They are:

- (i) Position of the motor shaft from the resolver.
- (ii) Desired position of the indexer command.
- (iii) Previous current commands of the amplifier.

An indexer will generate a stream of pulses that the controller collects with an up/down (i.e. clockwise/counter clockwise) counter. The resultant pulse count, at any



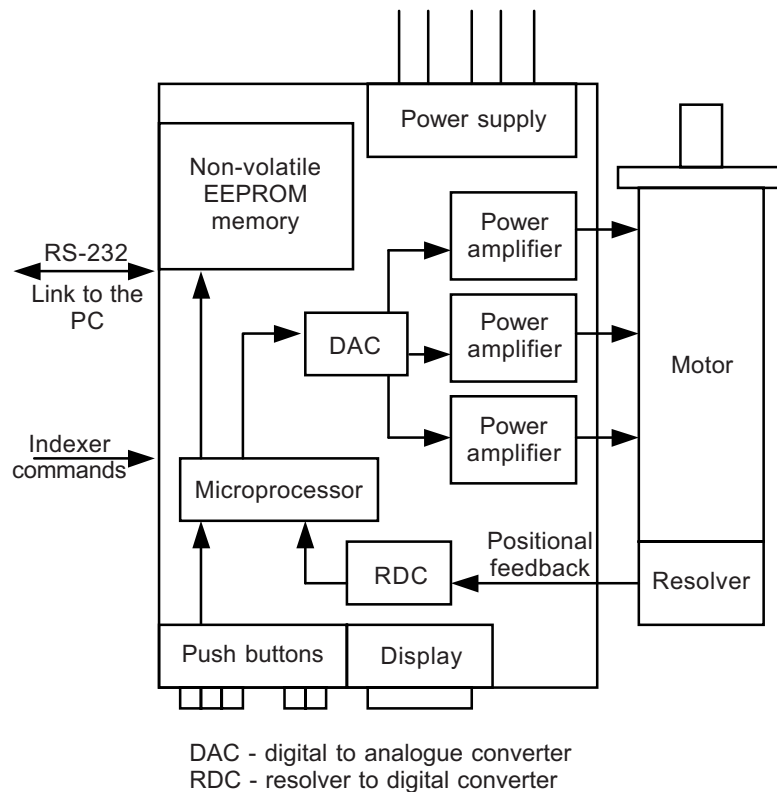

**Figure 4** Drive servo system

given instant of time, is the desired position. The controller will subtract the motor's actual position from this desired position to determine the positional error. The positional error is the difference between the desired motor position and the actual position. This positional error is used by a recursive equation, together with the previous positional errors, and the previous commands to the amplifier, to generate the current command for the amplifier.

The recursive equation is a mathematical function that is evaluated at periodic time intervals. The recursive equation of the drive is an approximation of an analogue, continuous-time PID (proportional, integral, derivative) network that is used quite often in stabilising conventional servo systems. The drive's recursive equation is the discrete-time equivalent to a continuous-time PID network.

It is called a discrete-time PID network because it operates on sampled data and not on continuous data. The sampling rate of the drive controller is the rate at which the recursive equation is evaluated and the current command to the amplifier is changed. The sample-rate of the drive controller is 512 microseconds and such a fast rate can produce excellent dynamic response.

The digital controller board handles all the positioning compensations like proportional, integral, derivative, and velocity gains (V). The effects of the PID and V

(proportional, integral, derivative, and velocity gain) to the system's response are:

- (i) Proportional gain. It will affect the system stiffness and accuracy.
- (ii) Integral gain. It allows the system to compensate for positional errors in static position.
- (iii) Derivative gain. It will add damping effects to the system.
- (iv) Velocity gain. It is used to affect the overall responsiveness of the system.

The most important aspect of a servo system is setting the controller's "gains". The "gains" of the controller are the constant coefficients of the recursive equation. The form of the recursive equation will determine how many of these "gains" should be adjusted in order to stabilise the system. The methods of adjusting the drive's servo compensation network are:

- (i) The five push buttons on the drive front panel.
- (ii) The RS-232 serial communication port.

#### 2.2.2.2 TUNING OF THE DRIVE

The drive has five push buttons on the front panel that provide a simple push button method of fine tuning the systems performance to a specific attached load. Before trying to set the gains of the controller, it is important to observe the response of the system to commands from the indexer and the stiffness of the system at rest.

With the motor at rest, if attempt is made to turn the shaft, it should not be easily turned from its rest position. If it feels soft, the system gains may need to be increased since a soft system will not respond very quickly to the motion commands. If it feels stiff, the system should be checked so that it is not vibrating. The gain may be too high if there is vibration. Vibration will cause the drive to provide excess current and can shorten the life of mechanical components. In extreme situations, the vibration will grow in amplitude, producing ever more violent motion until the drive faults or something breaks. As a result, tuning the drive should be done with some caution. After the completion of the push button tuning procedure, it will be necessary to save the selected term values into the non-volatile EEPROM memory.

The tuning process of the front panel push buttons can be duplicated through the RS-232 serial communication port with an interface program. The drive's RS-232 connector is a standard 25-pin "D" connector. It has a three-wire implementation of this interface and provides Receive Data (pin 2), Transmit Data (pin 3), and Ground (pin 7). No handshaking is required for the interface. The interface program enables communication between a PC and one or multiple drives. The command and response are strings of characters. It is assumed that:

- (i) The PC's serial card is set as either COM1 (3F8 Hex) or COM2 (2F8 Hex).
- (ii) The communication protocol is configured as:
  - (a) Baud rate = 9600
  - (b) Data bits = 8
  - (c) Parity = None
  - (d) Stop bits = 1
- (iii) The drive/s is/are connected to COM1 or COM2 of the PC.
- (iv) Each drive's device address is set.

The connection between the PC and the drive is important in order to make sure that communication is smooth. The RS-232 connector pin outs for most computers are:

25 Pin "D" Connector ——— 2 (Transmit Data), 3 (Receive Data), 7 (Ground)  
 9 Pin "D" Connector ——— 2 (Transmit Data), 3 (Receive Data), 5 (Ground)

Thus, the computer serial port pin 2 must be connected to pin 3 of the drive serial port. The drive serial port pin 2 must be linked to pin 3 of the computer serial port. The ground of the two serial ports must be connected. As more than one drive is used, it is necessary to construct a daisy chain cable to connect all the drives to the PC. Figure 5 shows the daisy chain wiring.

The interface program is a DOS platform software. The first step of using the program is to verify and set the communication protocol (baud rate, data bit, stop bit, and parity) and the selected serial port (COM1 or COM2). Once the settings are correct, the validity of the RS-232 connection has to be checked. Then, the RS-232 link has to be enabled and the push button functions (except the reset function) of the drive have to be disabled. After the tuning process, the tuning control has to be returned to the push button functions of the drive. Any command that will cause the drive to transmit information to the RS-232 port must be prefixed with a device address. This is to prevent several drives from transmitting simultaneously in the daisy chain wiring.

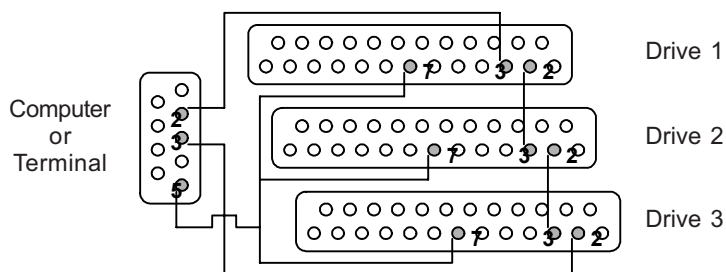

**Figure 5** Daisy chain wiring

### 2.3 Ball Nose End Milling System

The subtractive prototyping process is a ball nosed end milling cutter. A ball nosed cutter has cutting edges at the end and around the cutter. Hence, single point cutting can be accomplished by using the cutting edge at the end of the cutter. The cutting edges at the periphery of the cutter enable multiple cutting operations to take place at different time interval.

The size of the milling chips is small. Hence, the produced surfaces are smooth. Ball nosed end milling cutter can produce virtually any kind of surfaces. It has the advantage of making holes compared with the conventional end milling.

The subtractive prototyping equipment consists of the following components:

- (i) Ball nosed cutter.
- (ii) Digital drive.
- (iii) Drive holder and support.

Ball nosed slot drill was selected due to its versatility in producing various kinds of surfaces and features. The specification of the drill is 6 mm diameter, 8 percent Cobalt screwed shank standard ball nosed slot drill (Sherwood, CTL 061 5955F). The ball nosed cutter was mounted onto the clamping chuck of a EUROSTAR digital d.c. motor [10]. The maximum tool diameter allowed is 10 mm. The ball bearing equipped d.c. motor has a quiet synchronous belt drive. The motor is controlled via a computer-controlled speed regulator using pulse width modulated voltage (PWM). The whole drive unit is maintenance free and suitable for continuous operation. The motor current is electronically limited and has anti-stall as well as anti-overload system.

The nominal speed value is constantly compared with the actual speed value of the output shaft and variations will be corrected. This will ensure a constant speed during the milling process. In an overload operation, the drive can deliver doubled output for a short time to even out load peaks which could, for instance, occur if the milling material is not homogenous throughout the whole cross section. The possible speed is continually adapted to operating conditions to ensure that the speed is as close as possible to the nominal speed set.

The entire drive holder unit and half of the support component are from Bosch BS45 holder and support equipment. The drive holder is 210 mm in length and sits on a 535 mm long hollow metal tube. The tube is in turn supported by two aluminium blocks. The aluminium blocks and the whole unit of robotic manipulator are mounted on a 70 mm by 140 mm by 10 mm aluminium base plate.

The milling material used in the project is an extruded polystyrene [11]. The material is found to be a good choice for milling because minute chips can be removed during the prototyping process and smooth surface can be created. Its properties are not the same as the normal white color polystyrene used to protect electrical appliance in the packaging industry. The material's minimum density is  $32 \text{ kg/m}^3$ , its

thermal conductivity is 0.028 W/mK (measured at 10°C), and its compressive strength is 300 kN/m<sup>2</sup>.

### 3.0 RESULTS

A robot assisted subtractive prototyping system was built. A high-end PC was connected electronically to the indexer. The indexer was in turn connecting and controlling the drives. The drives were connected to the a.c. brushless servomotors. The motors were either connected mechanically to the lead screws or gearboxes of the manipulator to generate motions. A ball nosed end milling equipment was also built so that the whole system can be used to generate three dimensional complex shaped surface models.

The system was tested by integrating with the computer-aided design (CAD) software (AutoCAD and AutoSurf) and the author-developed computer-aided manufacture (CAM) programs. The CAD software was used to produce complex shaped surface models and neutral format file. The CAM programs were used in data processing and controlling the whole system for milling purposes. A CAD test model was used to test the system. The CAD test model is illustrated in Figure 6. The milling parameters are listed as below.

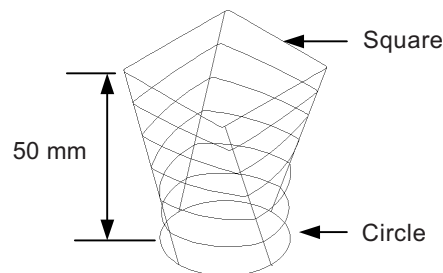

**Figure 6** CAD model

Spindle velocity : 1000 revolution per minute  
 Feed rate : 0.375 mm per second along  $x$ -axis  
               : 0.9° per second (0.0157 radian per second) around  $x$ -axis

(The feed rate along  $y$ -axis is synchronised with the other two motion axes.)

Milling time : 3.82 hours  
 Production time : 4.39 hours

The milled model is illustrated in Figure 7. The diameter of the first milling path (circle) for the milled model had been measured and compared with the dimension

of designed models. The design diameter, average measured diameter, and percentage of error are listed as below.

Design diameter	: 31.2566 mm
Average measured diameter	: 31.2250 mm
Percentage of error	: 0.1%

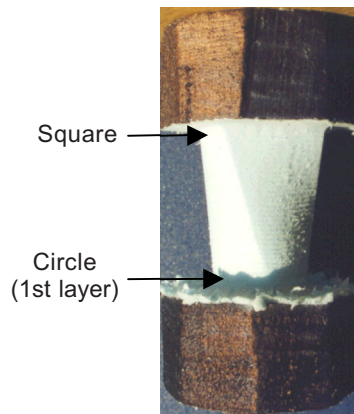

**Figure 7** Milled model

#### 4.0 DISCUSSION

As stated in section 2.2.1, the indexer is meant for PC/XT, AT or any IBM compatible personal computers. What will happen if the PC is different from the above stated models? What is the effect of using high-specification PC? What are the counter measures to be applied so that powerful PC can be used? The answers to the above questions are stated in the following paragraphs.

In this project, 3 kinds of PC were tested to link with the indexer and they were PC/XT, 486DX33, and Pentium II 300 PC's. By following the indexer manufacturer's advice, PC/XT is the right choice. However, its processing speed is only 4.77 MHz. Furthermore, its memory (RAM) and hard disk capacity are only 640 Kbytes and 20 Mbytes respectively. Hence, the PC/XT's processing speed is very slow compared with the available PC in the market. Besides, such a low memory and hard disk capacity computer cannot accommodate other softwares, like AutoCAD and Mechanical Desktop (computer-aided design package). Thus, a 486DX33 PC was used to replace the PC/XT computer.

Initially, using a 486DX33 PC to link with the indexer proved to be feasible in functionality and performance aspects. Besides, software such as AutoCAD R11 (DOS version) can be used on this PC. However, further testing revealed the weakness

of communication between a 486DX33 PC and the indexer. The system began to deviate from its normal functionality. The motion axes were not moving in a synchronous manner and the whole system hanged in the middle of the process.

The cause of the problem is the difference in microprocessor execution speed. The indexer main circuit board is using a MC68008P8 microprocessor. This microprocessor is too slow if compared with the 486DX33 microprocessor. Hence, the communication between the 486DX33 PC and the indexer is not smooth. The solution was to use a program called Mo'Slo [12] to slow down the execution speed of the PC. Hence, the PC can be used for other means besides controlling the robotic manipulator.

A 486DX33 PC was still not quite suitable for the project because of the limitations in speed, memory, and hard disk capacity. A Pentium II 300MHz PC is a better choice in controlling the precision manipulator since it has a better microprocessor and higher speed. Windows based softwares like Microsoft Office 97, AutoCAD R13, Mechanical Desktop, and Borland C++ 4.5 Programming Language can also be used by the same computer since the PC has 128 Mbytes of RAM (random access memory) and about 5 Gigabytes of hard disk space.

However, the PC's higher execution speed cannot be reduced using a program. As a result, the routines for sending commands and receiving responses from the indexer must be changed in order to solve this problem. The initial routines had a particular number of loops for communicating with the indexer. The revised routines will continue to wait until the indexer gives a response.

Hence, the latest PC was successfully integrated with the indexer to control the robotic manipulator. The new control program can be used to solve the interfacing problem if any higher specification personal computer is used in the future. Command execution speed difference due to the difference in the microprocessors of the indexer and the personal computer will not pose a problem.

However, the final solution of the above matter might cause another unwanted problem. The problem might arise if the indexer is faulty and did not respond during the operation. As a result, the system will wait indefinitely.

The PC has a very large RAM and hard disk capacity. A number of applications can be run at the same time. Its microprocessor and clock speed is so fast that the executions of all the applications can be carried out smoothly without sacrificing the speed. Thus, it is suitable for running powerful CAD softwares like AutoCAD and AutoSurf (part of Mechanical Desktop package). It is also capable of executing programming software like Borland C++ 4.5.

However, when the control program is executing the commands to produce the subtractive prototyping product, other applications in the PC cannot be used. It is to ensure that the control program is not interrupted by the time sharing feature of the microprocessor for producing high precision product.

Due to the nature of the subtractive prototyping control program and the model definition co-ordinate system, only three axes were used and they were the manipulation along  $x$ -axis, around  $x$ -axis, and along  $y$ -axis. The manipulation unit around the  $y$ -axis was not used in the project since it was very stable and not easily moved by external forces. As a result, the manipulation unit around the  $y$ -axis was not locked during the subtractive prototyping process.

The gearbox of the manipulation unit around  $x$ -axis was contributing a maximum backlash of three minutes ( $3' = 0.000873$  radian). The backlash of  $3'$  is negligible. The manipulator provided a fairly high precision motion, and this was proved by examining the surface roughness and the dimension of the milled polystyrene model.

The axes of the robotic manipulator moved synchronously. Synchronised motion means all the motion axes move and stop at the same time. The motion of the precision robotic manipulator can be synchronised in two ways.

One way is to use the pause and continue commands. As long as the pause command is located before the go command in a sequence of motion commands, then, the indexer will delay the execution of the motion. The indexer will initiate the motion once the continue command is received. The indexer's command processor is constantly switching sequentially from one axis to another for handling command processing. The time sharing process switches every two milliseconds. Time difference between different motion axes will affect the accuracy and smoothness of a complex surface since the surface is defined by a large number of motion commands. Thus, such method was not used in this project.

The second method is to enable the function of pre-calculating the motion data by the indexer. The pre-calculated move data will be sent over to each motor axis buffer. The buffer can accommodate up to one thousand characters' command at one time. Then, the indexer will let each motor axis to start moving within 150 microseconds of one another. The second method was employed in this project since the time difference between each motion axis is only 150 microseconds (maximum) if compared with the first method where the time difference between each motion axis is two milliseconds.

The original ball nosed cutter was attached to a Bosch hand drill. The hand drill was found to be unsuitable because it cannot run continuously for a few hours. As a result, the IKA drive unit that can stand long machining hours has been used to replace the Bosch hand drill as the subtractive prototyping tool. The new drive unit has the advantage of controlling the rotating speed of the cutter.

The surface finish of the products is acceptable. Some of the milling chips were still attached to the model surface due to the natural properties of extruded polystyrene block. The milled polystyrene models were found to have craters. This might be caused by the vibrations of the ball nosed cutter drive unit and the natural properties of the polystyrene. The cutter drive can be more stable if its base is supported from the ground instead of overhanging in the air. The cutter drive vibration can also be reduced by fixing an air cushion to it.



The dimensional accuracy of the product was good. The dimensional difference may be due to the positioning system of the manipulator, the milling vibration, and the natural properties of the polystyrene, which tend to have chips attached on the surface or crater. It is expected that the average percentage of error for all the models of the project will be much lower if there is no attached chips or crater on the surface of the models.

The actual machining time is different from the overall production time because at least 13 percent of the production time was used in commands transfer and execution. Motion command from the PC and the response from the indexer are transferred one character at a time between the PC and the indexer. The indexer has a very low command execution speed as well. It is believed that the bottleneck of the whole system lies on the two factors mentioned above.

## 5.0 CONCLUSION

Generally, the hardware and interface system configuration, which consists of a personal computer, interfacing system (indexer, drives and motors), robotic manipulator, and ball nosed cutter equipment were integrated seamlessly. The system was tested by integrating with the CAD and CAM programs for producing subtractive prototyping models.

The system has the following advantages:

- (i) Effective. The system can produce complex shaped objects with high accuracy.
- (ii) Time saving. Complex shaped objects can be produced in hours without sacrificing the surface roughness and accuracy.
- (iii) Space saving. The robotic based rapid prototyping system can save the floor space compared to the NC or CNC based systems.
- (iv) All in one. All the CAD/CAM activities can be done by one personal computer.

## ACKNOWLEDGEMENTS

We would like to thank Universiti Putra Malaysia, Malaysia, for sponsoring the study.

## REFERENCES

- [1] Yan, X., and P. Gu. 1996. A Review of Rapid Prototyping Technologies and Systems. *Computer-Aided Design*. 28(4): 307-318.
- [2] Styger, L. 1993. Rapid Prototyping and Tooling Technologies. *Materials World*. 1(12): 656-658.
- [3] Styger, L. 1994. Rapid Prototyping & Tooling: The Enabling Technology of the 90's. *IEE Colloquium (Digest)*. 1.1-1.5.

- [4] Merchant, M. E. 1985. Computer Integrated Manufacturing as the Basis for the Future. *Robotic and Computer Integrated Manufacturing*. 2(2): 89-99.
- [5] Fadel, G. M., and C. Kirschman. 1996. Accuracy Issues in CAD to RP Translations. *Rapid Prototyping Journal*. 2(2): 4-17.
- [6] Kruth, J. P., M. C. Leu., and T. Nagagawa. 1998. Progress in Additive Manufacturing and Rapid Prototyping. *Annals of the CIRP*. 47(2): 22-30.
- [7] Belforte, D. A. 1986. Robotic Manipulation for Laser Processing. *Proceedings of the SPIE-High Power Lasers and Their Industrial Applications*. 262-270.
- [8] Tse, W. C., and Y. H. Chen. 1997. A Robotic System for Rapid Prototyping. *Proceedings of the 1997 IEEE International Conference on Robotics and Automation*. 1815-1820.
- [9] Bhatti, M. T., and M. S. J. Hashmi. 1990. Software and Hardware Design of a Robotic Manipulator for the Manufacture of Complex Shaped Dies. *Journal of Material Processing Technology*. 24: 473-483.
- [10] IKA Labortechnik. 1998. *EUROSTAR Digital User Guide*. Germany.
- [11] Dow Chemical Company Limited. 1995. *Roofmate SL Extruded Polystyrene*. U.K.
- [12] <http://www.hpaa.com/moslo/>. accessed on 16 January 2003.