

FLOW REGIME IDENTIFICATION USING NEURAL NETWORK-BASED ELECTRODYNAMIC TOMOGRAPHY SYSTEM

MOHD FUA'AD BIN HJ RAHMAT¹ & HAKILO AHMED SABIT²

Abstract. Process tomography is a low cost, efficient and non-invasive industrial process imaging technique. It is used in many industries for process imaging and measuring. Provided that appropriate sensing mechanism is used, process tomography can be used in processes involving solids, liquids, gases, and any of their mixtures. In this paper, the process to be imaged and measured involves solid particles flow in gravity drop system. Electrical charge tomography or electrodynamic tomography is a tomographic technique using electrodynamic sensors. This paper presents the flow regime identification using neural network.

Keyword: Process tomography, neural network, electrodynamic sensor, identification

Abstrak. Proses tomografi adalah suatu teknik membina imej yang murah, cekap dan sesuai untuk proses di industri yang kini semakin diguna pakai untuk tujuan pemantauan proses dan pengukuran. Mekanisme pengesanan dalam proses tomografi bergantung kepada bahan aliran dalam paip industri sama ada pepejal, gas atau cecair. Dalam kertas kerja ini, proses yang terlibat adalah pengaliran pepejal kering dalam paip mengikut arah graviti dan mekanisme pengesanan yang digunakan ialah penderia elektrodinamik. Pengenalpastian rejim aliran daripada pengukuran penderia adalah dengan menggunakan rangkaian neural yang akan mengenal pasti aliran pepejal sama ada dalam aliran penuh, suku separuh dan tiga suku.

Kata kunci: Proses tomografi, rangkaian neural, penderia elektrodinamik, pengenalpastian

1.0 INTRODUCTION

Tomography is a far more efficient, low cost, and robust method than the traditional methods in industrial process imaging and measurement. In the past two decades, many types of tomography have been developed and applied in measuring different flows ranging from single phase flow to multiphase flow using different sensors.

Tomography comes from the Greek words *tomo* (slice) and *graph* (picture). The Helicon Encyclopedia defines tomography as the obtaining of plane section images, which show a slice through an object [1].

The Oxford English dictionary defines tomography as: Radiology in which an image of predetermined plane in the body or other object is obtained by rotating the detector

¹ Control and Instrumentation Department, Faculty of Electrical Engineering, Universiti Teknologi Malaysia, 81310 Skudai, Johor. E-mail: drfuaad@fke.utm.my

² Faculty of Electrical Engineering, Universiti Teknologi Malaysia, 81310 Skudai, Johor. E-mail: ha-sabit@lycos.com

and the source of radiation in such a way that points outside the plane give a blurred image. Also in extended use, any analogous technique using other forms of radiation [2].

Process tomography is similar to medical tomographic scanners in many aspects except that it is applied for obtaining industrial process images. The application of tomography in industries for obtaining images of processes in pipelines, process tanks, etc, is termed as process tomography. Furthermore, process tomography is less costly, faster, and more robust, compared to medical tomography.

Process tomography can be applied to many types of processes and unit operations, including pipelines, stirred reactors, fluidized beds, mixers, and separators. Depending on the sensing technique used, it is non-invasive, inert, and non-ionizing. It is therefore, applicable in the processing of raw materials in large scale and intermediate chemical production and also in food and biotechnology areas [3].

The tomographic measurement data is manipulated using algorithms for image reconstruction, profile analysis, and numerical quantities such as flow rates, concentration, size, and phase distribution [4].

Electrical charge tomography is a process tomography using electrodynamic sensors. Electrodynamic sensors consist of two parts, sensing electrode and signal conditioning circuit. The sensing electrode is a conducting (silver steel) rod and is insulated from the wall of the conveyor pipe by a nylon plug. The use of the sensing electrode is to detect charge on the flowing particles.

The signal conditioning circuit consists of amplifiers and filters. This part of the sensor converts the sensed charge to a voltage signal, amplifies it, and make it available in three forms of outputs. The first output of electrodynamic sensor is an ac signal which can be used to obtain the velocity of flow. The second output is a rectified signal and can be used for spatial filtering tests. The third output is an averaged voltage signal and can be manipulated for process imaging. The diagram of electrodynamic sensor is shown in Figure 1.

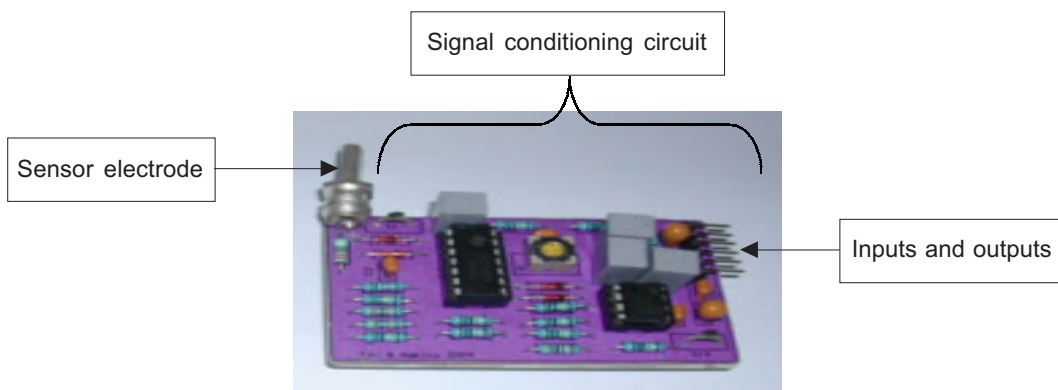

Figure 1 Electrodynamic sensor

The motivation for using electrodynamic sensors as the sensing device in tomography arises from the fact that many flowing materials pick up charge during transportation, primarily by virtue of friction of fine particles amongst themselves and abrasion on the wall of the conveyor [5].

The solids and powders involved in industries are not pure clean substances and the level of electrification is affected by the surface contamination, impurities or absorbed materials, rather than the basic chemical construction of the solids or powder [6].

It has been established that the magnitude of the charge acquired by solids depends on the moisture content of the atmosphere, the particle size distribution, and the velocity with which the particles move and/or impinges onto surface [6].

Based on the above facts, electrodynamic sensors can be used to detect the quantity of charge on the flowing materials and convert it to equivalent electrical signal (voltage), so that spatial information of the flowing materials at a cross-section of the conveyor could be obtained to provide tomographic images.

Electrodynamic sensors have the disadvantage of being non-linear. This limitation of electrodynamic sensors can be remedied using filter masks for different flow regimes. However, prior knowledge of the flow regime is necessary to determine the type of filter mask to apply. A gravity flow rig is used in this project and due to the nature of the feeder in this kind of flow rig, it is impossible to know the flow regime being conveyed. Therefore, a feedforward neural network is used to identify the flow regimes, and then the corresponding filter mask is used for the flow regime identified by the neural network.

2.0 NEURAL NETWORKS

Artificial Neural Networks (ANN) have been applied successfully in several decision making, data classification, process identification, and other problems with excellent accuracy, even under noisy conditions. Multilayer feedforward ANN with backpropagation learning algorithm is the most commonly used ANN tool among the various model of ANN and it is used in this project. Since backpropagation is classified as supervised learning algorithm, input vectors and the corresponding target vectors are used to train the network until it can approximate a function, associate input vectors with specific output vectors or classify input vectors in an appropriate way as defined by the user. Properly trained backpropagation networks tend to give reasonable answers when presented with inputs that they have never seen.

3.0 TOMOGRAPHIC IMAGE RECONSTRUCTION

Tomographic data and images shown in this project are obtained using gravity flow rig, as shown in Figure 2.

An array of 16 electrodynamic sensors were fitted around the circumference of the conveyor, equi-spaced, and 1.4 m down the feeder. The solid particles induced charges

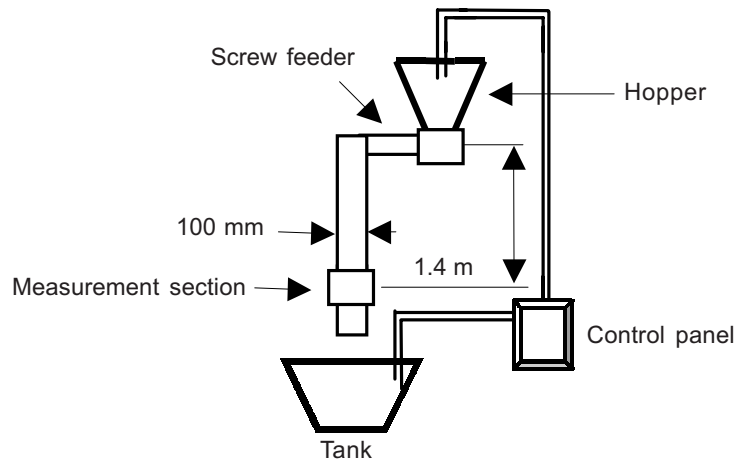

Figure 2 Gravity flow rig

into the sensing electrodes as they passed the sensors down the conveyor pipe. Data from each sensor is then collected and stored for image reconstruction process by a high speed data acquisition card (Keithley DAS 1800) used as an interface to a personal computer (PC). The PC then processed the data using tomographic image reconstruction algorithms, obtained the type of flow regime from the neural network, applied the filter mask, and sent the final tomographic image of the process to the displaying device (monitor). The tomography system is shown in Figure 3.

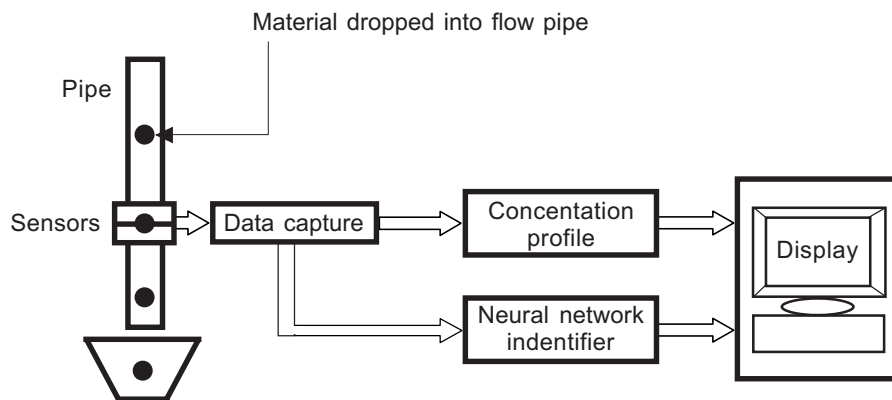

Figure 3 Overview of tomography system

The tomographic images are calculated from the measurements using filtered back-projection algorithm, which is derived from the forward problem. The forward problem determines theoretical output of each of the sensors when the sensing area is considered to be two-dimensional and contains a uniformly distributed charge of δ coulombs per square meter [7].

3.1 Linear Back Projection Algorithm

The cross-section of the pipe is mapped onto a rectangular array of 11×11 pixels (121 pixels), as shown in Figure 4. The sensitivity of each sensor is generated by calculating the charge which a chosen pixel, if a unit charge is placed at that pixel, would induce into the sensors using equation 1.

$$I = \int \left(\frac{\delta}{r^2} \right) dA \quad (1)$$

where δ is the surface charge in cm^{-1} , r is the distance of the charge (pixel) from the sensors, and A is the pipe cross-section area.

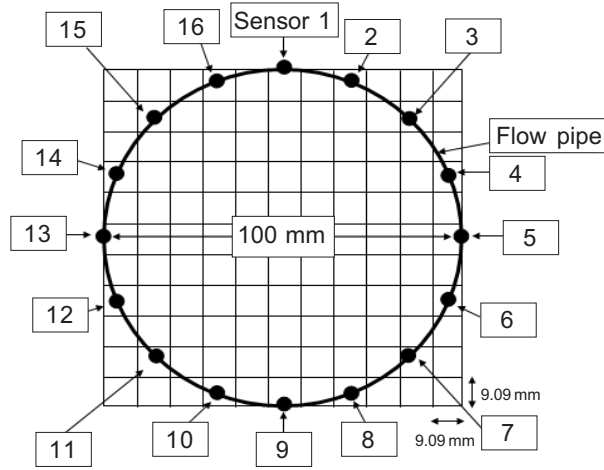

Figure 4 11×11 rectangular array with the cross-section of the pipe mapped onto it showing sensor positions

If the centre of the pipe is assigned a rectangular coordinate of (0,0) with the pipe of 100 mm diameter and each pixel has a dimension of 9.09×9.09 mm, then the sensitivity equation of sensor 1 would be:

$$I_1 = \int_x dx \int_y \frac{\delta}{x^2 + (50 - y)^2} dy \quad (2)$$

if δ is assumed to be 1 cm^{-1} the induced charge of sensor 1 is calculated as:

$$I_1 = \int_{-50}^{50} dx \int_{-\sqrt{(50^2 - x^2)}}^{\sqrt{(50^2 - x^2)}} \frac{1}{x^2 + (50 - y)^2} dy \quad (3)$$

In a similar fashion, the sensitivity map of each sensor is computed and the data from each sensor is to be multiplied by its sensitivity map to provide 16 matrices of size 11×11 .

The corresponding individual elements from the 16 matrices are to be summed to provide linear back projection concentration profile. Theoretical concentration profiles can be obtained using linear back projection algorithm and assuming each sensor read 1V (theoretical case of uniform full flow). It is clear from this profile that the concentration value decreases toward the center of the pipe even though it was assumed there is a uniform distribution of particles. This arises due to the non-linear sensing mechanism of electrodynamic sensors. This limitation can be eliminated using filtered back projection algorithm.

3.2 Filtered Back Projection Algorithm

Filter masks for various flows are generated by taking the highest pixel value of linear back projection concentration profile and dividing it by each pixel value. The filter masks for full flow, three-quarter flow, half flow and quarter flow, would be generated. For example, the filter mask for full flow is generated by assuming all sensors read 1V, for half flow, 8 of the 16 sensors should be assumed to read 1V and the other 8 sensors read 0V, and similarly for other filter masks. Filtered back projection concentration profile is obtained by combining the linear back projection concentration profile with its corresponding filter masks.

4.0 FLOW TYPES

Known flow regimes are generated using baffles and the data obtained is stored to train a neural network to identify future flow regimes based on the training data. The feedforward artificial neural network using backpropagation algorithm is trained to determine the flow regimes using the data obtained by introducing baffles to artificially generate known flow regimes. The flow regimes generated using baffles are three-quarter flow, half flow, and quarter flow. Data for four different flow regimes is obtained including full flow, which is obtained without using any baffle. For the purpose of training the neural network, the flow regimes were designated using binary codes as in Table 1.

Table 1 Flow regimes and their corresponding codes

No	Flow type	Code
1	Full flow	1111
2	Three-quarter flow	0111
3	Half flow	0011
4	Quarter flow	0001

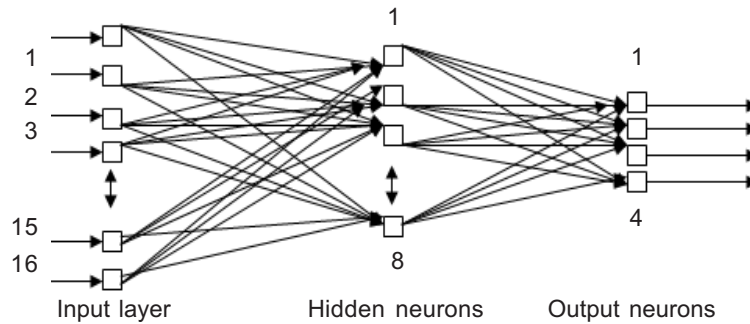

Figure 5 Fully connected backpropagation network

Backpropagation network with biases, 16 neurons at the input layer, 8 neurons at the hidden layer, and 4 neurons at the output layer as shown in Figure 5, is trained using data from the 16 sensors as input vectors, and the above binary codes as target vectors. The network also uses tan-sigmoid transfer function in its middle layer and log-sigmoid transfer function in its output layer. The purpose of using log-sigmoid at the output layer is to limit the output in the range of 0 to 1 because the targets are within this range.

After deciding the optimum learning rates to get a stable network that neither takes too long to converge nor oscillate, the network is trained (its weights are adjusted) and used to classify the flow regimes from the real data.

The training result of the network using MATLAB software is shown in Figure 6.

```

» resilient2
TRAINRP, Epoch 0/100, MSE 0.280339/1e-005, Gradient 0.671533/1e-006
TRAINRP, Epoch 10/100, MSE 0.0686664/1e-005, Gradient 0.579076/1e-006
TRAINRP, Epoch 20/100, MSE 0.0484836/1e-005, Gradient 0.0116494/1e-006
TRAINRP, Epoch 30/100, MSE 0.00288739/1e-005, Gradient 0.0257224/1e-006
TRAINRP, Epoch 40/100, MSE 6.87262e-005/1e-005, Gradient 0.000491313/1e-006
TRAINRP, Epoch 43/100, MSE 4.4957e-006/1e-005, Gradient 6.05918e-005/1e-006
TRAINRP, Performance goal met.

```

Figure 6 Training result of the network of figure 5

5.0 RESULTS

To achieve good generalization of the neural network tool used, sufficient quantity of data is required. The results shown in Figures 7 are based on a small quantity of data available at the time. However, it is enough to show the possibility and potential of the method used. Table 2 shows samples of the training data for various known flow regimes created using different baffles and their flow regimes. Figures 7 (a,c,e,g) show the tomographic images of solid particles flow in the gravity flow rig and Figures 7 (b,d,f,h) show the same images after applying the filter masks.

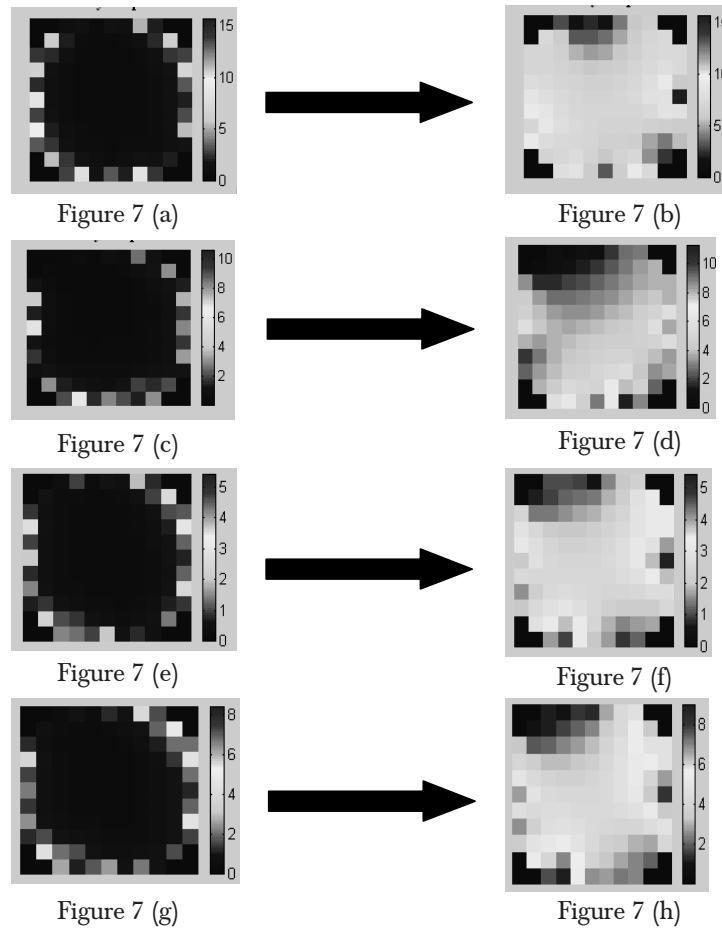
**Figure 7** Tomographic images**Table 2** Training data and their flow codes

Sensor No.	1	2	3	4	5	6	7	8	9	10	11	12	13	14	15	16	Flow code
Data(52g/s)	.25	.25	.2	.3	.15	.4	.3	.25	.26	.22	.22	.2	.21	.2	.22	.25	1111
(80g/s)	.5	.5	.4	.7	.55	1	.25	.9	1	.89	.8	.6	.6	.5	.55	.5	1111
52g/s	.2	.2	.3	.5	.49	.8	.75	.81	1	.96	.95	.8	.7	.5	.4	.25	0111
80g/s	.25	.25	.36	.7	.69	1.5	1.3	1.8	1.9	1.8	1.8	1.7	1.6	1.5	.5	.4	0111
52g/s	.2	.2	.25	.3	.4	1	1.2	1.5	1.8	1.7	1.5	.7	.6	.5	.4	.3	0011
80g/s	.2	.2	.25	.4	.6	1.5	1.8	2.4	2.9	2.5	2	1.4	1	.8	.5	.4	0011
52g/s	.1	.1	.1	.1	.18	.5	.7	1.5	1.8	2	1.6	1	.5	.2	.15	.1	0001
80g/s	.15	.14	.1	.13	.25	.7	1.4	2	2.7	2.6	2.4	1.2	.6	.25	.2	.12	0001

6.0 DISCUSSION

The ability of electrodynamic tomography to interrogate solids flow in gravity drop system and provide an accurate flow image is clearly noticeable from the results shown in Figures 7. Electrodynamic sensors, however, have a main drawback which affects the accuracy of the measurement data. This drawback is due to the non-linear sensing mechanism of the electrodynamic sensors, which can affect process monitoring if it is not properly compensated for. In order to compensate for this drawback, filter masks have been developed which correspond to different flow regimes. The flow regimes have to be identified using a feedforward neural network tool.

7.0 CONCLUSION

A category of neural networks known as feedforward network has been employed in identifying the flow regimes in the gravity flow rig. Feedforward neural network with few input and output neurons, and sufficient hidden layer neurons is found to be able to identify the flow regimes provided that it is trained on sufficiently enough sample data from the system. As could be seen from the preliminary results tomogram (tomographically reconstructed flow image), the correct identification of flow regime which then determine the filter mask to apply, significantly improves the accuracy of the tomograms.

REFERENCES

- [1] Rahmat, M.F. 1996. Instrumentation of Particles Conveying using Electrical Charge Tomography. PhD Thesis. Sheffield Hallam Univ.
- [2] Industrial Process Tomography Group, UMIST URL <http://www.tomography.umist.ac.uk/whattom.shtml>
- [3] Azrita, A. 2002. Mass Flow Visualization of Solid Particles in Pneumatic Pipelines using Electrodynamic Tomography System. M.E. Thesis. Universiti Teknologi Malaysia.
- [4] Bidin, A.R. 1993. Electrodynamic Sensors and Neural Networks for Electrical Charge Tomography. Ph.D. Thesis. Sheffield Hallam Univ.
- [5] Cross, J. 1987. Electrostatics; Principles, Problems & Applications. Adam Hilger.
- [6] Shackleton, M. E. 1982. Electrodynamic Transducers for Gas/Solids Flow Measurement. Phil Thesis. University of Bradford.
- [7] Green, R. G., M. F. Rahmat, K. Evans, A. Goude, M. Henry., and J. A. R. Stone. 1996. Concentration Profiles of Dry Powders in a Gravity Conveyor using an Electrodynamic Tomography System. *Meas. Sci. Technol. Journal* 8: 192-197.