

Sonar Assistive Device for Visually Impaired People

Muhammad Haziq Kamaludin^a, Nasrul Humaimi Mahmood^{a*}, Abd Hamid Ahmad^a, Camallil Omar^a, Masdinah Alauyah Md Yusof^b

^aFaculty of Electrical Engineering, Universiti Teknologi Malaysia, 81310 UTM Johor Bahru, Johor, Malaysia

^bLanguage Academy, Universiti Teknologi Malaysia, 81310 UTM Johor Bahru, Johor, Malaysia

*Corresponding author: nasrul@fke.utm.my

Article history

Received : 15 August 2014

Received in revised form :

5 January 2015

Accepted : 10 February 2015

Graphical abstract



Abstract

An affordable sonar assistive device was developed to facilitate the visually impaired people to walk inside or outside their homes. The device uses a sonar technology where each ultrasonic sensor consists of a transmitter and a receiver. The transmitter will transmit a signal to an obstacle in front of it and when the signal reaches an obstacle, the signal is reflected back. The reflected signal is then received by the receiver. The system of Arduino Pro Mini will then evaluate the echo to identify the presence of the obstacles. This ultrasonic sensor can detect obstacles as far as 4 meters. Hands-on testing was conducted to identify visually impaired people needs and to provide them an opportunity to use the device. The users were interviewed to find out about their experience. The results clearly show that 90% of the users were satisfied with the features of the device and they were also confident of using the device to detect different types of obstacles.

Keywords: Sonar technology; ultrasonic sensor; visually impaired

© 2015 Penerbit UTM Press. All rights reserved.

1.0 INTRODUCTION

Majority of the people thought that visual impairment is limited to only blindness. Visual impairment actually refers to both individuals with low vision and blindness. The Snellen test which is also known as a visual acuity test is commonly used to determine whether a person has a normal vision or low vision or suffers from blindness.

Traditional mobility aids such as long cane and dog guides have been useful in helping the blind or visually impaired to do many daily tasks. However, Clark-Carter *et al.* have investigated and reported that at least one-third of people with visual impairment or blindness make no attempt of independent journey inside and outside their homes.¹

Manduchi and Kurniawan have conducted several interviews between October 2009 until December 2009 with 307 visually impaired individuals from various countries such as Canada, New Zealand, Mexico, Indonesia and The United States of America.² The results from the survey revealed that almost 85% of the people with visual impairment experienced tripping when walking and thus resulting in a fall. Furthermore, the results showed that they were frequently exposed to waist-level and head-level injury. This is due to the limitations of the walking aids where these aids were only able to detect objects below the waist level. Travelling using these aids often led them to disorientation of walking, feeling stressful and confusion of their sense of direction.

Devices using sonar technology systems were introduced to improve the limitations of existing walking aids and to identify obstacles or objects.^{3,4,5} A sonar system would consist of a

transmitter and a receiver. The transmitter will transmit the sonar signal to an object in front of it and will reflect once the signal reaches the object. The reflected signal (echo) will be sent to the receiver. The system evaluates the echo to determine the presence of the object. Many aids or devices are currently designed using sonar technology because ultrasonic is more accurate and has a better range of detection compared to other sensors such as laser distance sensor and infrared sensor.

The sonar assistive device has acted as an important and effective affordable device which can help visually impaired or blind travellers to detect obstacles in the local environment, such as the entrance and exit of a building, drop-offs part, climb and descend stairways, as well as many other locations.^{6,7}

The development of technologies to assist people with visual impairment has improved with the advancement of computer systems technology, and many researches have been conducted to improve the result. Although the problems have been studied intensively, there still remain open and unsolved issues. There are some mobility aids or assistive technology devices that are still commercially available such as Guide Dog, Bat K-Sonar Cane, Ultracane, Electronic White Cane and Miniguide.⁸

A sonar assistive device which uses the sonar technology was developed to facilitate self-walking for the visual impaired, either inside or outside their homes. This project was conducted to evaluate the usage of the device based on the users' feedback (through questionnaire) and hands-on experiences. Interviews were conducted to gain these feedbacks.

2.0 SYSTEM DESIGN

An ultrasonic sensor sends out a sound wave and measures the echo that it received. This process is also known as sonar. The ultrasonic sensor uses a transmitter and a receiver to determine if an object is in front of it as seen in Figure 1 below.

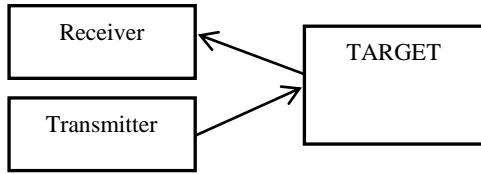

Figure 1 Visual representation of how an ultrasonic sensor works

A transmitter initially sends a pulse while a receiver looks for the returning signal. Sending and receiving a signal allows the sensor to determine the distance of an object by calculating the time elapsed between the emitting and receiving of the signal. The sensor is very good at determining the distance of an object from the sensor. One drawback that the ultrasonic sensor has is that when it is placed at an angle, it may not receive the signal back or it can cause false triggers. Another issue is that there is no way to distinguish objects from one another. The Equation (1) below is used to determine the distance of an object from the sensor.

$$d = \frac{c \cdot t \cdot \cos \theta}{2} \tag{1}$$

Where d is the distance of the object, c is the speed of sound in the air, θ is the angle of incidence between the signal and the object being detected, t is the time between the emission of a sound wave and detection of the echo.

2.1 Working Principles

Two ultrasonic sensors were placed at both right and left sides of the circuit board followed by two servos and two buzzers. The Arduino is powered by a Lithium Polymer (LiPo) rechargeable battery to make the device portable. Since the operating voltage for Arduino Pro Mini is 5V, the external 5V voltage regulator is used to regulate the voltage from LiPo rechargeable battery. The working principle of the sonar assistive device is shown in Figure 2.

From the flow chart, whenever any ultrasonic sensors detect an obstacle which is located at less than one meter, the servo and the buzzer will be on. Otherwise, the servo and the buzzer will remain off. If the obstacles are detected from the right side, the right servo will rotate and touch the user's skin, and the right buzzer will produce a sound as feedback information to the user. The pitches of the sound are different for the left and right buzzers. However, this working principle is applicable for both left and right side.

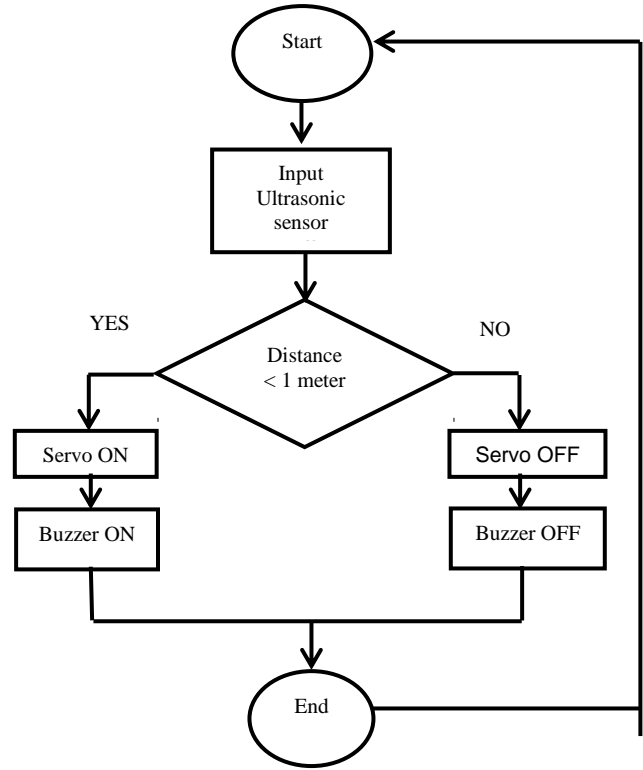

Figure 2 The working principle of the sonar assistive device

2.2 Programming and Testing

The Arduino programming language is a simple and clear programming environment. It is an open-source physical computing platform based on a simple microcontroller board, and a development environment for writing software for the board. Arduino programs can be divided into three main parts, which are structure, values (variables and constants), and functions. In order to insert the programs into Arduino Pro Mini, Arduino software is used.

The libraries that are used in this project are New Ping and Servo. The New Ping is a new library for many ultrasonic sensor models such as SR04, SRF05, SRF06 and Parallax PING. The library is easy to be used with multiple sensors, produce more accurate distance measurements, easy to correct the error and have a fast execution process. On the other hand, the Servo library is used to control servo motors such as HXT900 servo to drive and support up to 12 servos simultaneously on most Arduino boards.

All components are tested to ensure that the system is functioning as required in accordance to the flow chart shown in Figure 2.

2.3 Design and 3D Printing

Dimensions for each component were measured carefully before drawing the design of the casing to ensure that no errors complicating the assembly and installation process would occur later. Figure 3a and Figure 3b below show the bottom part and the top part of the casing using Solidworks software respectively.

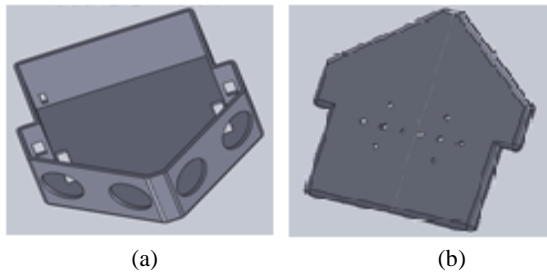

Figure 3 Solidworks design of the casing - (a) bottom and (b) top

A 3D printer was used to print the casing of the device using Acrylonitrile Butadiene Styrene (ABS) plastic as the raw material. The printing process took about four hours to produce the bottom part and one hour for the top part as shown in Figure 4.

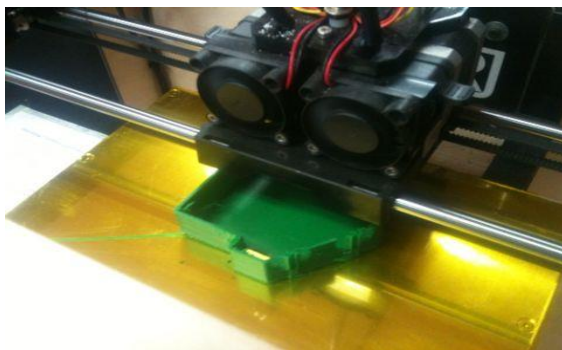

Figure 4 3D printing of the sonar assistive device casing

The appearance of the complete casing is shown in Figure 5 below. The casing was sandpapered and sprayed with lacquer aerosol spray to obtain a smooth and shiny surface.



Figure 5 Final appearance of the sonar assistive device casing

2.4 Assembly and Wiring

All components were arranged and assembled into the final casing design by attaching them with hot glue. Then, the components were connected according to the circuit schematic which was designed using Fritzing software as shown in Figure 6. Since the internal voltage regulator in the Arduino Pro Mini is not able to cope with the current and voltage coming from the LiPo rechargeable battery, an external 5V voltage regulator, LM7805 is used.

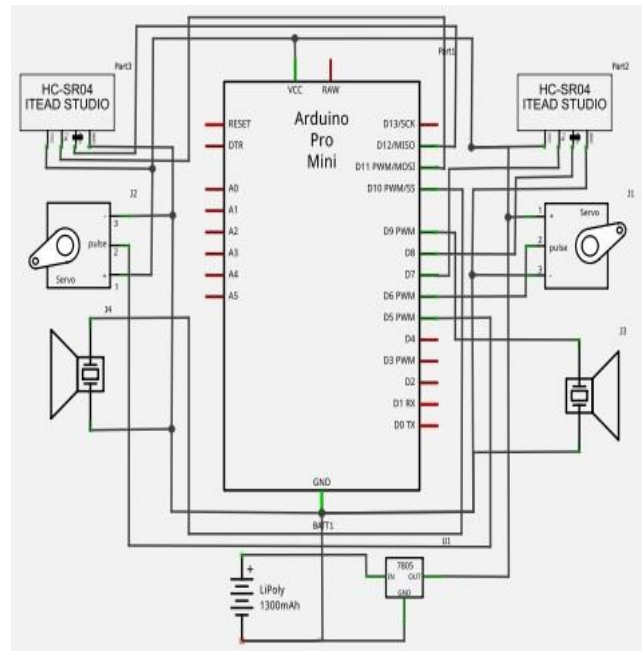

Figure 6 Circuit schematic of sonar assistive device

2.5 Hands-on Assessment, Feedback and Analysis

A hands-on testing was conducted with ten (10) volunteers with normal vision with their eyes closed (using sleeping mask) as shown in Figure 7. The subjects were observed and interviewed regarding their experiences using the device. All the interview responses were analysed to identify the degree of satisfaction among users in terms of the features of the device and their confidence level using the device.



Figure 7 Hands-on testing with normal people with their eyes closed

3.0 RESULTS AND DISCUSSION

3.1 Hardware

Figure 8 below shows the final look of the sonar assistive device. The device has wider range detection of the distance (more than 1 meter). Each ultrasonic sensor is consisted of a transmitter and a receiver. The concept of the sonar system used in the device is very simple. The transmitter will transmit the sonar signal to the obstacles and when the signal reaches the obstacles, the signal is reflected back (echo). The reflected signal is then sent to the receiver. The microcontroller of the system (Arduino Pro Mini) will evaluate the echo to identify the presence of the obstacles.

The device can detect obstacles as far as 4 meters and is secure because it does not have any contact with the objects when determining the presence of obstacles. This process proves that sonar technology is very suitable to be used in assistive technology for obstacle avoidance systems.



Figure 8 Final design/look of the sonar assistive device

The device is powered using a LiPo rechargeable battery to make the device portable and functional for about 3 to 5 hours. Figure 9 below shows how to charge the device using LiPo balance charger. Once the battery is fully charged, all LED on the charger will change their colour into green.

Whenever the users want to use this device outside their home, they can use it together with the attached glove to keep the device from falling off and to ensure that it remains in contact with the user's hand. The device can also be used on its own without using the glove if the users are using the device inside their home.



Figure 9 Charging of the device with the LIPO balance charger

3.2 Required Features of an Assistive Device Concerned by the Users

Figure 10 below displays the required features of an assistive device as suggested by the volunteers. It is clear that the volunteers were very concerned about the comfort and effectiveness of the assistive device. However, they have no significant comments on the dimensions of the device. Other features of the device such as the design, safety and user-friendliness had the same number of votes (six) from the volunteers. The price and durability of the device were voted eight and seven votes respectively.

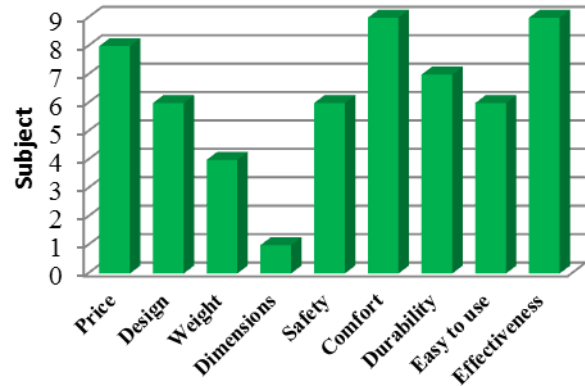

Figure 10 Required features of an assistive device concerned by the users (n=10)

3.3 Degree of User Satisfaction

About 30%, 50% and 50% of the volunteers were very satisfied with the features of the sonar assistive device which are its weight, dimensions and durability respectively. The above results are based on the questionnaire responses. The number of the users who were satisfied (both very and quite satisfied) with the design, safe and secure, comfort and user friendly of the Sonar Assistive Device are the same with the percentage of 90%. The remaining 10% of the users were neutral with the four features of the device mentioned.

3.4 Confidence Level of the Users

Figure 11 below shows the confidence level of the volunteers in detecting different types of obstacles when using the sonar assistive device. Overall, 90% of the volunteers were confident to use the device to detect different types of obstacles when their eyes were covered with the sleeping masks. However, 10% of the volunteers were not confident to use the device to detect the drop-offs and stairs.

The percentage of volunteers who were confident to detect obstacles below and above waist is the same, which is 90%. The number of the volunteers that are confident to detect the stairs using the device was slightly higher than the percentage for the drop-offs obstacles, which are 30%.

In conclusion, majority of the volunteers were confident to use the device because it is able to detect different types of obstacles at different levels, obstacles which are below waist level, above waist level, head-level, drop-offs and stairs. However, some of the volunteers were not confident to use the device to detect the drop-offs and stairs but this is a natural weakness or disadvantages of using the ultrasonic sensor.

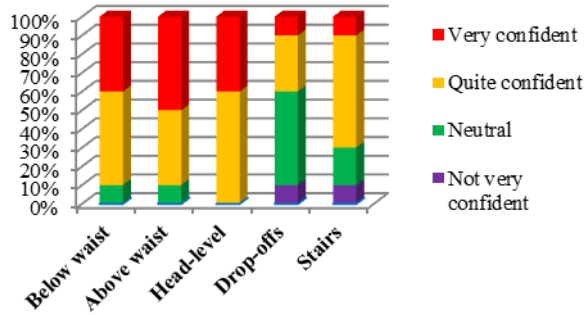

Figure 11 Confidence level of the subjects when using the sonar assistive device

4.0 CONCLUSION

Assistive technology has a potential role in increasing the quality of life for visually impaired people and in increasing the range of options available for them. The sonar technology used in the design of the proposed device has proven that it can be used as an assistive technology obstacle avoidance system.

The device is able to overcome the difficulties and accidents faced by visually impaired individuals while walking such as falls and head-level injuries. Besides that, the device is also able to facilitate them for self-navigating especially inside their homes.

Most of the volunteers of the hands-on testing were satisfied with the features of the device and majority of them were confident to use the device to detect different types of obstacles.

References

- [1] M. A. Hersh and M. A. Johnson. 2008. *Assistive Technology for Visually Impaired and Blind People*. 1st ed. Scotland and U.K. Springer.
- [2] R. and S.Kurniawan. 2011. Insight: Research and Practice in Visual Impairment and Blindness. *Mobility-Related Accidents Experienced by People with Visual Impairment*. 4(2): 1–11.
- [3] S. Cardin, D. Thalmann, and F. Vexo. 2005. *Wearable Obstacle Detection System for visually impaired People* Lausanne, Switzerland: Ecole Polytechnique de Lausanne, EPFL. 1–6.
- [4] J. Faria, S. Lopes, H. Fernandes, J. Barroso, and P. Martins. 2010. Electronic White Cane For Blind People Navigation Assistance. *World Automation Congress*. 1(1): 1–7.
- [5] M. F. Saaid, I. Ismail, and M. Z. H. Noor. 2009. Radio Frequency Identification Walking Stick (RFIWS): A device for the blind. *International Colloquium on Signal Processing and Its Application (CSPA)*. 5(9): 250–253.
- [6] M. Helmy, A. Wahab, A. A. Talib, H. A. Kadir, A. Johari, A. Noraziah, R. M. Sidek, and A. Ariffin. 2011. Smart Cane : Assistive Cane for Visually-impaired People. *International Journal of Computer Science*. 8(4): 21–27.
- [7] S. Y. Kim and K. Cho. 2013. Usability and Design Guidelines of Smart Canes for Users with Visual Impairments. *International Journal Design*. 7(10): 99–110.
- [8] S. T. Brassai, L. Bakó, and L. Losoncz. 2011. Assistive Technologies for Visually Impaired People. *Acta Univ. Sapientiae*. 3(1): 39–50.