

## Fault Monitoring System for Traffic Light

Muhamad Zaki Amin Marzuki<sup>a</sup>, Anita Ahmad<sup>a\*</sup>, Salinda Buyamin<sup>a</sup>, Khairul Hamimah Abas<sup>a</sup>, Seriaznita Hj Mat Said<sup>b</sup>

<sup>a</sup>Process Tomography and Instrumentation Engineering Research Group (PROTOM-i), Infocomm Research Alliance, Faculty of Electrical Engineering, Universiti Teknologi Malaysia, 81310 UTM Johor Bahru, Johor, Malaysia

<sup>b</sup>Language Academy, UTM Kuala Lumpur, 54100 Kuala Lumpur, Malaysia

\*Corresponding author: anita@fke.utm.my

### Article history

Received : 15 August 2014  
Received in revised form :  
5 January 2015  
Accepted : 10 February 2015

### Graphical abstract



### Abstract

Traffic light breakdown is very common. These create hassle as well as unsafe condition for road users. This project provides a new paradigm in traffic light monitoring system. The system has the capability to send multiple Short Message Service (SMS) to the contractor, traffic police and local council in the event of a malfunction traffic light. Normally, road users have to call the contractor based on the information displayed at the traffic light pole. With the current system, time taken to respond to the traffic light breakdown depends on how soon road users call the contractor. Monitoring system for fault traffic light will address this matter. In this project, the system can detect two types of failure, power failure and bulb/ Light Emitting Diode (LED) failure (a particular light not working i.e. red light only). Upon receiving the power failure signal, SMS will be sent to the above-mentioned parties for further action. For LED types of traffic light, the system has the capability to detect deterioration in function. If >50% of the LED for any light is not working the system will notify the contractor and other related parties to perform restorative action. The malfunction of LED can be detected by measuring real current vs the nominal current for that particular light. The seriousness of traffic light failure is divided into three parts, which are the total power failure, total LED failure and partial failure. The microcontroller analyzes the seriousness of the failure and sends the signal to a Global System for Mobile communications (GSM) module. Then the GSM module will send the details of failure including location and types of failure. For this project, LED was used as prototype of the traffic light.

**Keywords:** Traffic light failure; malfunction; GSM module; SMS; monitoring

© 2015 Penerbit UTM Press. All rights reserved.

### 1.0 INTRODUCTION

Traffic light, also known as traffic signal or traffic lamp, is a signaling device and normally positioned at the intersection of the road. The main reason for installing traffic light is to ensure mobility of vehicles and improve safety at the road [1]. The first traffic light was installed at London in 1868. It consisted two gas lamps, one red and one green, with semaphore arms atop a pole. The signal of traffic light may be operated manually or by a simple timer [2]. Typically, it allows only one way traffic running at one time. Other signals operated by fuzzy logic controllers that sense traffic flow and the time of day. Then, the controller automatically adjusts the sequence of the signals operation. The basic subsystems in modern traffic light are electric controller, signal lights in their housing and the supporting arms or poles. The color sequence in most country is red (stop), yellow (prepare to stop) and green (go) [3].

In Malaysia, Dewan Bandaraya Kuala Lumpur (DBKL) has selected Integrated Transport Information System (ITIS) to monitor the traffic flow in the city. ITIS also share updated traffic information to road users to help them plan their trips. At the same time, ITIS is used to monitor the condition of the traffic light system. ITIS system uses wired technologies (for communication and power supply), which increases their construction and maintenance cost. However, time taken to respond to the failure of traffic light is minimized resulting in the reduction of traffic jam caused

by traffic light failure. Figure 1 shows an example of traffic light that uses LED.



Figure 1 LED traffic light

Rapid growths of traffic increase the need for traffic lights, thus, resulting in more difficult and more complex traffic light monitoring job. The cost of installation and maintenance of the current surveillance camera system for traffic light is high, as the system needs a 24-hour human monitoring.

Normally, there is no surveillance system for traffic light in the rural area. Road users need to report a malfunctioning traffic light to the responsible authorities by phone. However, this depends on the alertness of the road user. The time taken to repair the malfunction traffic light might be longer if the road user does not file the report. Besides, time to trigger the appropriate course of action from the responsible department would have caused havoc in a busy area. A major accident as shown in Figure 2, which may lead to casualties, could happen.



Figure 2 Accident cause by traffic light failure

Therefore, the objectives of this project is to develop a system that can detect power supply failure, monitor the performance of LED traffic light and send SMS with details of faulty traffic light to responsible parties for further action.

2.0 EXPERIMENTAL SET-UP

2.1 Overview

The project begun with collection of information related to the monitoring system for traffic light. Some previous research on traffic light was reviewed to get more information on the topic. The research about GSM modem has also given additional information in designing the system. The idea and concept is important to make sure the monitoring system is suitable for the application [4].

The research helps in finding the best monitoring system for traffic light and GSM modem to ensure the system is effective in detecting malfunctioned traffic light and to send the details via SMS. After that, the design of the system and complete circuit was produced. The hardware and circuit design are important in order to choose suitable materials and electronic components for the system. These include the study of the circuit design and mechanical design.

After completing the electronic and mechanical design, the real system was constructed followed by the software implementation, which was a programming development in order to achieve the objective of this project. During the process, numerous improvements and troubleshooting were done to make sure all parts of the system working properly.

2.2 Hardware Development

A model of traffic light was developed using a simple timer and IC 4017. The schematic diagram of the traffic light is shown in Figure 3, where all the components such as timer, IC 4017, resistor and capacitor are assembled together in one board.

A 555 timer is used as the master timer IC and a 220kΩ is applied for the timing purpose. A 10μF capacitor controls the timing pulses, which gives a period of about three seconds. IC 4017 is a 10 stage decode counter, thus the sequence of the traffic light is spread over 10 clock pulses. Two outputs from the IC 4017 drive both green and red LED to obtain a longer time sequence, while the yellow LED is driven by only one output. This gives about 6 seconds for both the red and green LED to react and 3 seconds for the yellow LED.

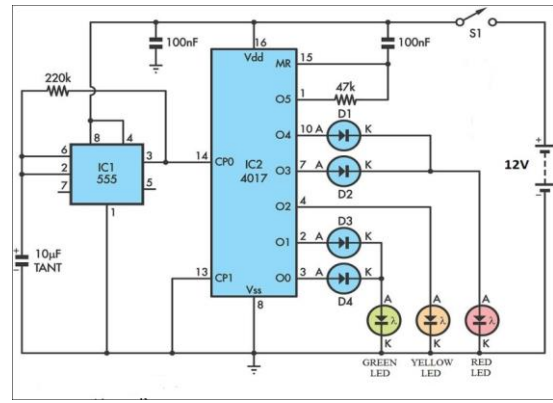

Figure 3 Traffic light schematic diagram

For this project, two sets of model traffic light were developed and installed in two different locations, namely traffic light 1 and traffic light 2. The operational power supply for both traffic light was 12VDC. For traffic light 1, seven LED for each color were installed while only 5 LED for each color were installed at traffic light 2. The LED was fed by external power supply, which was 5VDC. Figure 4 shows the LED installation of the traffic light.



Figure 4 LED installation of traffic light

2.2.1 Power Supply Failure Detection System

The system that can detect power supply failure of the traffic light has been developed in this project [5]. The schematic diagram for the power supply failure detection system is shown in t Figure 5. A PNP transistor has been used as a main switching device in this system. The transistor remains positively biased as long as the traffic light power supply is present. This makes the transistor workable when it is in OFF mode and exhibits the battery power to send a signal to the microcontroller.

In addition, this circuit has been designed so that the power supply can recharge the battery through resistor, R2 when the current is limited. Once the traffic light power supply is cut off, the transistor will instantly change to be forward biased and turn the transistor ON. Then, the LED indicator is turned ON and sends the signal to the microcontroller.

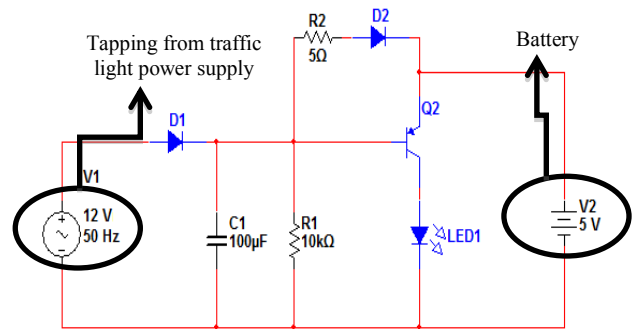

Figure 5 Power supply failure detection system schematic diagram

The circuit board of power supply detection system has been installed in parallel with the circuit board of the traffic light. Figure 6 shows the power supply detection system circuit board installation. A socket is prepared to connect with the actual traffic light power supply and connects to the 12V power supply failure detection system circuit. This shows that the power supply detection system can be easily installed with minimum modification to the existing circuit of traffic light.

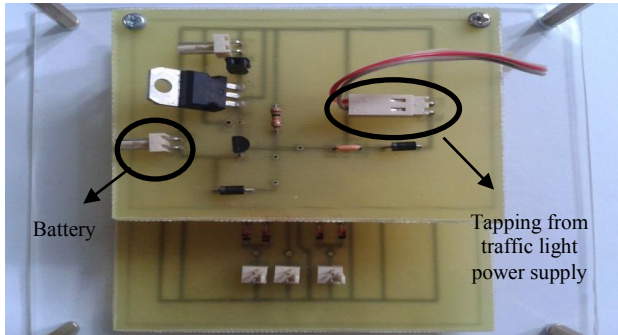

Figure 6 Power supply failure detection system installation

2.2.2 LED Malfunction Detection System

The malfunction of LED can be detected by measuring the total current output for that particular LED. The neutral connection of LED bypasses the two terminals in the current sensor. LED comes in two colors, green and red have been selected for monitoring as these two colors are critical if they malfunction. ACS 712 current sensor in Figure 7 was selected to measure the current in this project. The device consists of a precise, low-offset, linear Hall circuit with a copper conduction path located near the surface of the die. This current sensor was selected due to the following reasons:

- i. Low cost & easy to obtain;
- ii. Portability & low power consumption;
- iii. Available in three current ranges which are 5A, 20A and 30A;
- iv. Low-noise analog signal path; and
- v. Extremely stable output offset voltage.



Figure 7 ACS 712 current sensor

2.2.3 Arduino UNO R3

The brain for this system is the microcontroller. For this project, Arduino UNO R3 manufactured by Cytron was selected as the microcontroller. Figure 8 shows microcontroller Arduino UNO R3. The microcontroller was based on ATmega328 chip. The microcontroller will receive the input data from the power supply failure detection system and current sensor. Then, the data is sent to the final control element (GSM modem). Table 1 shows the port connection for Arduino. Arduino UNO R3 was selected as microcontroller in this project because:

- i. it is the latest in a series of USB Arduino boards;
- ii. it consists of 14 digital I/O pins, which is 6 provide Pulse Width Modulation (PWM) output;

- iii. it has low operating voltage, which is 5V;
- iv. it reserves pin for future purpose; and
- v. it uses ATmega16U2 instead 8U2 as USB-to-Serial converter.



Figure 8 Arduino UNO R3

Table 1 Port connection of Arduino UNO R3

Port	Function
Digital 4,D4	Traffic light 1 power supply
Digital 5,D5	Traffic light 2 power supply
Analog 0,A0	Green LED current sensor
Analog 1,A1	Red LED current sensor

2.2.4 ICom2.2.4 IComsatSIM900

IComsat is a GSM/ General packet radio service (GPRS) shield for Arduino and is based on the SIM900 Quad-band GSM/ GPRS module. It is controlled via AT commands (GSM 07.07,07.05 and SIMCOM enhanced AT Commands. This GSM modem has been selected because it is fully compatible with Arduino / Iteduino and Mega. Therefore, the programming microcontroller becomes easier to handle because it shares the same command window. In addition, power on/off and reset functions are supported by Arduino interface. A user can choose either to reset both devices or use the GSM modem only. The power supply of the GSM modem can be shared with the Arduino UNO R3. In this project, GSM modem was installed between both the traffic light distribution boards. The cost for the installation had been reduced due to the low usage of wire connection. Figure 9 shows the installation of the GSM modem.



Figure 9 GSM modem installation

2.2.5 Slide Switch

Slide switch was used as switch to simulate the traffic light power supply and LED. This type of switch was selected because of easy handling and low cost. To cut off the power supply of traffic light, slide switch must be in OFF position. For LED uses, each LED is connected to the slide switch. In this project, the seven-slide switch is connected to the seven LED at the traffic light 1. Figure 10 shows the installation of the slide switch in this

project. In addition, the main slide switch had been installed at the power distribution board to control the whole power supply for the system.



Figure 10 Slide switch installation

2.2.6 Power Supply

For this project, the power supply was fed from a single AC to DC adapter. The 12V 2A adapter in Figure 11 had been selected as it meets the power consumption requirement for the project. It can support the input from 100V to 240V and 50/60 Hz. A voltage regulator was used to manage the voltage need for certain system in this project.



Figure 11 Adapter

2.3 Block Diagram

Figure 12 shows the block diagram of the system. Based on the block diagram, it shows how the four inputs are sent to the microcontroller, which relayed the signal to the GSM modem

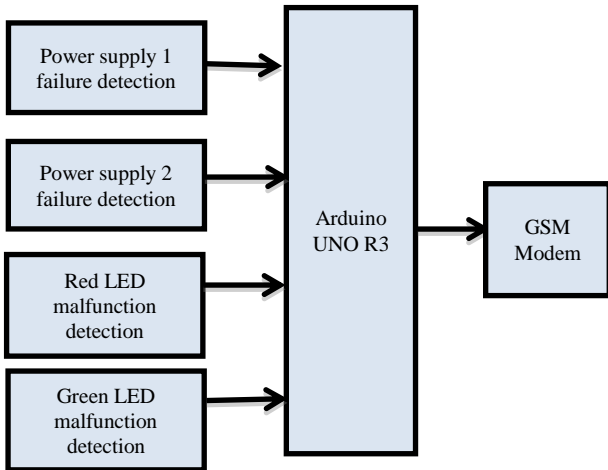

Figure 12 Block diagram

2.4 Software Development

For software implementation, C programming language was used to program the microcontroller. The flow chart for the system is shown in Figure 13. The microcontroller will be initialized when the power supply is switched ON.

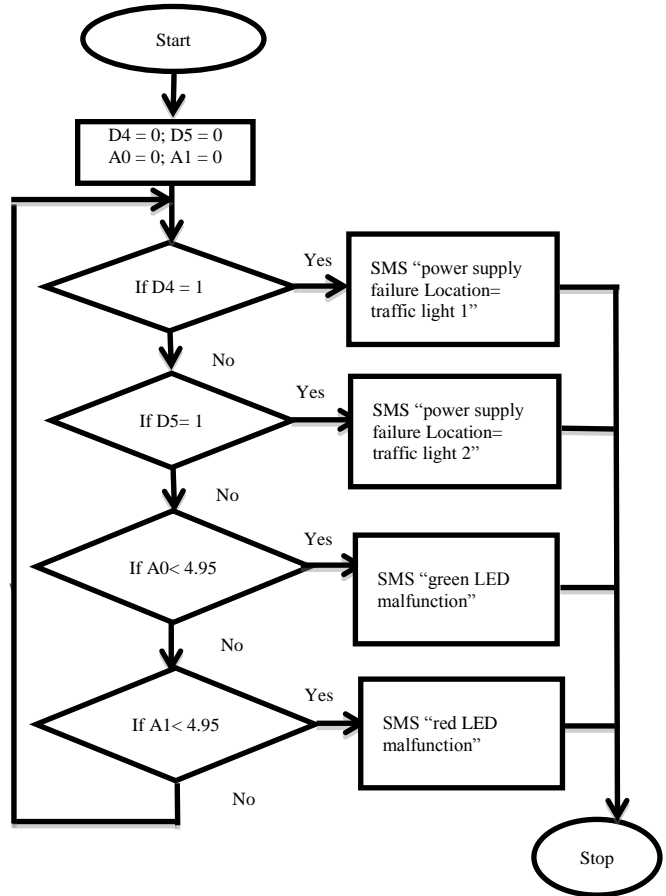

Figure 13 Flow chart

As mentioned in chapter 3.4.4, the port D4, D3, A0, and A1 was reserved as input data from power supply traffic light 1, power supply traffic light 2, green LED malfunction and red LED malfunction. Resetting the value of D4, D5, A0 and A1 to zero value will start the system accordingly, thus avoiding the offset value from the sensor and affects the value calculated. The microcontroller reads the signal from D4 and analyzes the signal. If the value is low or 0V, it will proceed to the next stage, which is to analyze the input from D5. Then, the next stage is the A0 input analysis, which takes place if D5 input shows zero value.

For the LED malfunction analysis, the analog port reads the value from the current sensor continuously. There is a formula that needs to be considered in order to calculate the current value from the LED. The formula of the current sensor is:

$$\text{Sensor value} = \frac{(510 - \chi) \times 27.03}{1023}$$

where:

- 5 = value from current sensor
- 510 = zero error value from sensor
- 27.03 = the sensibility of sensor

A half value of the total LED output current (4.95 mA) is used as a set point for the current analysis. The program will proceed to the next step when the current is higher than 4.95 mA. The process goes to the new cycle if the red current sensor value is higher than 4.95 mA.

### 3.0 RESULTS AND DISCUSSION

In this chapter, the test result for the system hardware and software is shown. The testing was done in stages to make sure the hardware and software function as designed. The testing was divided into three stages: Traffic Light Testing, Failure Detection System Testing and Sending SMS Testing. The discussion is based on the result of the test.

#### 3.1 Traffic Light Testing

The model traffic light has gone through several stages of testing. The sequence of traffic light was tested to make sure it is according to the standard. This model meets the standard, which is the first color is green and then followed by yellow color. The time for yellow is shorter compared to green and red. The last color sequence in a cycle of traffic light is red and it goes back to green color. Figure 14 shows the sequence of the traffic light. The power supply is tested using a different value between 9 V to 12 V. 12 V power supply was the best option because the sequence and LED brightness was more stable.

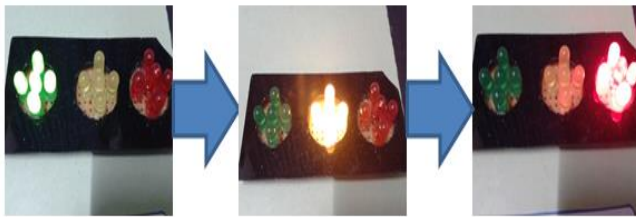

Figure 14 Traffic light sequence

#### 3.2 Failure Detection System Testing

The value of output current was gathered to monitor the performance of LED. Seven slide switches controlled LED. Table 2 shows the result of the output current. The result shows that the value of the current decreases as the number of turned ON LED decreases. The value was displayed at Arduino serial monitor.

When all LED was turned ON, the current value was 8.02 mA and 7.12 mA when six LED was turned ON. We take three as the minimum number that LED must be turned ON and the result value was 4.80 mA. So, we take 4.95 mA as the reference value of the LED performance monitoring. The current value is zero when all the LED was turned OFF.

Table 2 LED Current reading

No. of LED turned ON	Current value, mA
7	8.02
6	7.12
5	6.34
4	5.76
3	4.80
0	0

#### 3.3 Sending SMS Testing

The third objective of this project is to send details of traffic light failure to the responsible parties via SMS. GSM modem has been tested in stages as it is the main device to send SMS [6]. Power supply detection system was the first stage of GSM modem testing. The microcontroller has the capabilities to analyze different location of the traffic light and send the signal to GSM modem. After that, GSM modem will proceed to send SMS to responsible parties. Two samples different SMS are shown in Figure 15. The detailed of failure and traffic light location was displayed in the SMS.

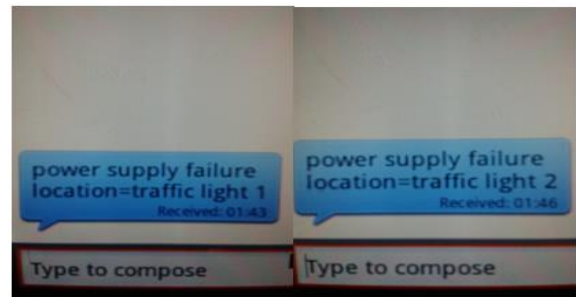

Figure 15 Power supply failure SMS

The second stage of GSM modem testing was the LED performance system. Two colors, green and red had been monitored. . Arduino UNO R3 analyzes the input data from the current sensor and sends the signal to the GSM modem. If the current sensor value is lower than 4.95 mA, Arduino UNO R3 gives a command to the GSM modem to deliver the SMS. Figure 16 shows a sample SMS alerting LED failure.

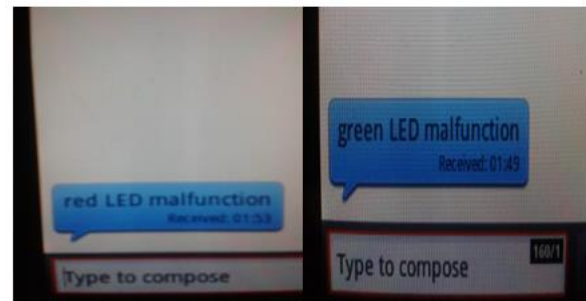

Figure 16 LED failure SMS

### 4.0 CONCLUSION

In conclusion, this project has successfully designed and tested a fault monitoring system for traffic light. Three objectives have been considered in this project after about a review on monitoring system of traffic light and GSM modem. Setting up the objectives is the first and the most important task in this project. When the vision of the research was clear, the development of project started gaining its momentum. Additionally, a review on journal articles relevant to the project had been conducted to gain more idea and information on the latest technology implementation. Some journal articles were also used as reference to increase the scope of limitation. The methodology process which followed suit focus on hardware and software implementations. A detailed hardware implementation gives good result in terms of design and cost consumption. At the same time, the programming design was conducted to ensure that the hardware meets the research objectives. The next process was testing and data gathering. The testing was conducted by stages to monitor result, which was then tabulated and analyzed. Based on the result analysis, it shows that the project has met all the objective requirements.

#### Acknowledgement

The authors would like to thank the Ministry of Higher Education and Universiti Teknologi Malaysia for supporting this research under SLAI scholarship.

#### References

- [1] Koay, B. K. and M. M. Isa. 2009. Traffic Light System Design on FPGA. In *Research and Development (SCORed)*, 2009 IEEE Student Conference on.

- [2] Roger Gorham. 2009. *Demystifying Induced Travel Demand*. Sustainable Transportation Technical Document, Sustainable Urban Transportation Project ([www.sutp.org](http://www.sutp.org)).
- [3] Sivarao, Siva Kumar Subramanian, Mazran Esro & T.J.S. Anand. 2010. Electrical & Mechanical Fault Alert Traffic Light System Using Wireless Technology. *International Journal of Mechanical & Mechatronics Engineering IJMME-IJENS*. 10(04).
- [4] V. R. Gannapathy, S. K. Subramaniam, A. B. Mohamad Diah, M. K. Suaidi, A. H. Hamidon. 2008. Risk Factors in a Road Construction Site. *Proceedings of the World Academy of Science, Engineering and Technology*. 46: 640–643.
- [5] Pituk Bunnoon. 2013. Fault Detection Approaches to Power System: State-of-the-Art Article Reviews for Searching a New Approach in the Future. *International Journal of Electrical and Computer Engineering (IJECE)*. 3(4): 553–560.
- [6] R. Santha kumar, Dr. K. Kaliyaperumal. 2014. Applications of GSM Technology For Documents Identification In A Library System. *International Journal of Academic Library and Information Science*. 2(1): 1–6.