

# Mobile Inspection Robot for Heating, Ventilation and Air Conditioning (HVAC) Ducting Systems

Amirah 'Aisha Badrul Hisham<sup>a</sup>, Wong Liang Xuan<sup>a</sup>, Mohamad Hafis Izran Ishak<sup>a\*</sup>, Nurul Hawani Idris<sup>b</sup>, Abdullah Mohd Nawi<sup>c</sup>

<sup>a</sup>Infocomm Research Alliance, Control and Mechatronic Engineering Department, Universiti Teknologi Malaysia, 81310 UTM Johor Bahru, Johor, Malaysia

<sup>b</sup>Faculty of Geoinformation and Real Estate, Universiti Teknologi Malaysia, 81310 UTM Johor Bahru, Johor, Malaysia

<sup>c</sup>Language Academy, Universiti Teknologi Malaysia, 81310 UTM Johor Bahru, Johor, Malaysia

\*Corresponding author: hafis@fke.utm.my

## Article history

Received : 15 August 2014

Received in revised form :

5 January 2015

Accepted : 10 February 2015

## Graphical abstract

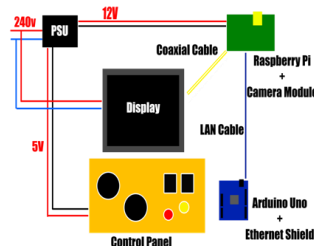

## Abstract

Indoor air quality is an issue often neglected by the public. One of the main issues is due to the unawareness of importance of scheduled maintenance of Heating, Ventilation and Air Condition (HVAC) ducting systems. A contaminated ventilation duct is able to spread biological and non-biological pollutants throughout the building and result in Sick Building Syndrome (SBS). Accumulated dust can be the spreading medium for contaminants. Moreover, the size of ducts is often small and difficult to be examined. In this paper, a mobile inspection robot solution is developed to overcome the problem. It is equipped with a camera to provide forward vision and a mechanical gripper to take samples of suspected harmful or contagious substances. It is also able to brush off the dust in the duct if necessary. Due to the long distance needed to be travelled by the tethered cable, a User Datagram Protocol (UDP) is used to ensure the command signal. The robot is expected to be able to maneuver in the ducts and capture live video for the operator.

**Keywords:** Mobile Robot; heating, Ventilation and Air Condition (HVAC); Sick Building Syndrome (SBS); User Datagram Protocol (UDP); Raspberry Pi

© 2015 Penerbit UTM Press. All rights reserved.

## 1.0 INTRODUCTION

The effect of indoor air quality on human health is an issue that has been a concern in recent years. Studies have been carried out to identify the causes of indoor air pollutants and find out the impact of poor indoor air quality on humans.

A contaminated ventilation duct is able to spread biological and non-biological pollutants throughout the building and result in Sick Building Syndrome (SBS) [1, 2]. SBS is more common in modern airtight buildings under the operation of Heating, Ventilation and Air Condition (HVAC) systems compared to naturally ventilated buildings. Symptoms of SBS are usually non-specific, but it is observable that the symptoms worsen when human subjects are inside a contaminated building and ease or disappear after leaving the building.

HVAC technology is implemented in industry and buildings in large scale nowadays. The technology is important as it regulates temperature, humidity and quality of air using fresh air from outdoors. Fresh air intake from outdoors is ventilated and ducted throughout the building. A contaminated ventilation duct is able to spread contaminants inside the building. For example, in a

hospital, it is a must [3] to run ventilation duct checkups periodically.

A ducting system usually consists of different components such as turning ducts, diverging ducts, air dampers and filters [4]. The condition and cleanliness of these ducts are difficult to evaluate due to the differences in the size and length of these components for a human to go inside for inspection [5]. Additionally, there is an element of risk involved if the person has to climb into the duct since ducts are installed at a higher level. Therefore, a solution is suggested, which is to inspect the condition of the inner ducting system using a mobile robot.

Using a mobile robot was based on Neves and Matos' work [6] which was to apply stereovision to small water vehicles. They used webcams and a Raspberry Pi model B in their project to apply the stereo vision on the small water vehicles. Furthermore, in [6, 7] the researchers also applied Arduino microcontrollers in their embedded system project.

The main objective of this project is to develop a robot which is capable of inspecting the condition of ventilation ducts. The robot has to be small in size to fit into most of the ducts to do the inspection. The user would have the ability to monitor and control

the robot movement in the duct through the monitor screen fed from the forward camera. The robot is also able to retrieve suspected harmful substances in the ventilation duct using an attached robot arm. Last but not least, the robot is able to brush off the dust in the duct if necessary

## 2.0 METHODOLOGY

### 2.1 Overall System

The earlier stage of project implementation required proper planning in order to prevent any mistakes that could happen during the development process. Therefore, a big picture of the whole project is very important. It is visualized and shown in the figures below. Figure 1 shows the control panel layout while Figure 2 shows the robot system layout.

The whole project is generally divided into two parts which are the control panel part and the robot part. The main components in the control panel part are a display monitor, a microcontroller with Ethernet supported which is connected by the inputs and most importantly the power supply unit (PSU). The robot part must include the DC and servo motor which some servo motor has limitation of rotation angle [7]. Additionally, a forward camera also has to be attached to the robot.

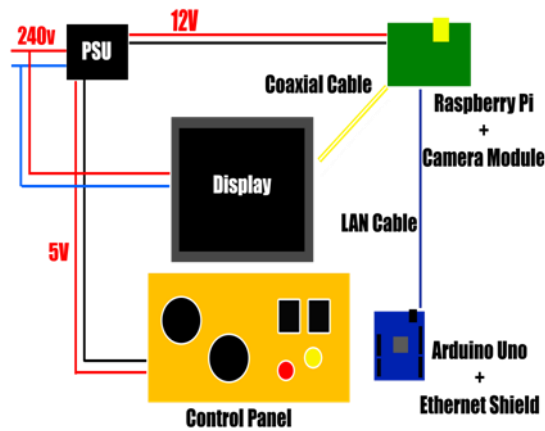

Figure 1 Control panel layout

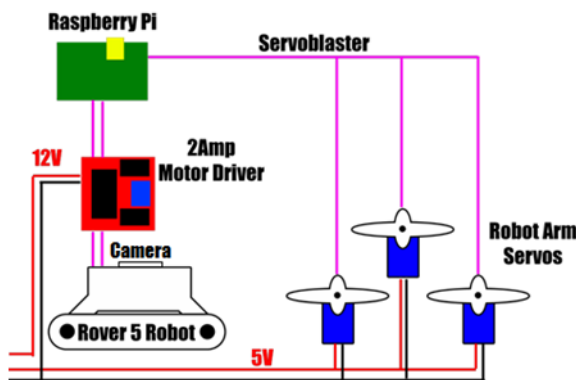

Figure 2 Robot system layout

### 2.2 Control Panel

The control panel part is made up of the display monitor, power supply unit and an Arduino Uno [8] with Ethernet Shield to command the movements of the robots. It has two joysticks, two buttons and two toggle switches to control the robot. Joysticks are used to control the base movement and the camera arm movement whereas the buttons are used to control the mechanical gripper if connected. The toggle switches are used to control the brush movement and Light Emitting Diode (LED) headlights. The joysticks are known as potentiometer or variable resistor later in the schematic diagram in Figure 3.

The control panel inputs are connected to the Arduino Uno. According to the Arduino official website, Arduino is an open-source electronics prototyping platform based on flexible, easy-to-use hardware and software. It is intended for artists, designers, hobbyists and anyone interested in creating interactive objects or environments. The use of this board is easy and the open-source software allowed everyone to obtain the source code easily. Early development starting with Arduino is encouraged because many projects have been completed and shared on the World Wide Web.

Nevertheless, Arduino is unsuitable for projects which require heavy computational calculation because the processing speed is limited by the microcontroller. Arduino Uno features 32 kilobytes of flash memory, 2 kilobytes of Static Random Access Memory (SRAM) and Electrically Erasable Programmable Read-Only Memory (EEPROM). Its clock speed is 16 megahertz. It also has 14 digital input and output pins and 6 analogue input pins [9]. Figure 4 shows the Arduino Uno. Joystick inputs are connected to the analogue input pins whereas push buttons and toggle buttons are connected to digital pins. The Arduino Uno is attached with an Ethernet shield to expand its capability to send commands via LAN Cable. The Ethernet shield communicates with Arduino Uno using Serial Peripheral Interface (SPI). The communication is internally handled by the fully functional Ethernet Library.

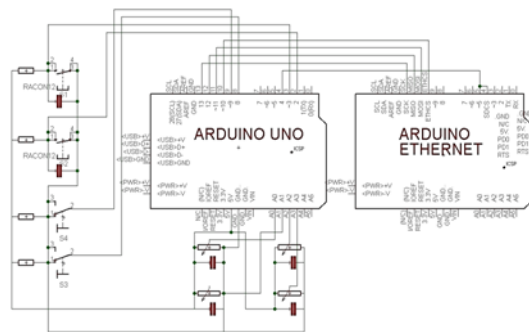

Figure 3 Schematic diagram for arduino uno and ethernet shield with control panel inputs



Figure 4 Arduino uno

**2.3 Control Panel Communication Protocol**

The input data from the control panels are rearranged and fit into the 10 bytes of character array, which is also a string and later will be sent to the Raspberry Pi. The details of the string will be visualized in Figure 5.

It is shown in Figure 5 that there are 10 bytes of character array or string that is sent from control panel to Raspberry Pi. The initial three bytes are 'F', 'Y' and 'P' to indicate the Raspberry Pi is receiving the data from the control panel. The fourth character is the size of data, which contains a value of 5 in this project. Since the toggle buttons and push buttons give only one bit of output, it is therefore possible to combine all four buttons into the lower nibble of one character where the upper nibble is ignored and remains 0 all the time. The Analogue to Digital Converter (ADC) of the Arduino Uno is 10 bits resolutions and requires two bytes of data space to store it. Hence, ADC outputs from the joysticks are divided by four so that they are able to fit into one byte from value 0 until 255.

Checksum algorithm is to get the summation of all data which are about to send neglecting the overflow of value. Checksum is sent to a receiver so that the receiver is able to check if the received data is exactly the same as the sender's by matching the checksum using the same algorithm.

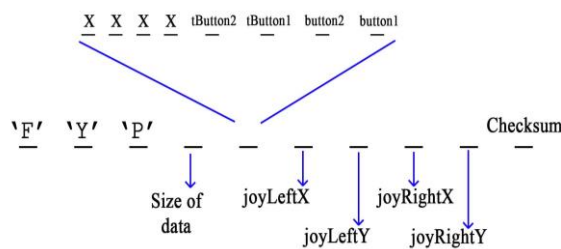

Figure 5 String package to be sent from control panel to raspberry Pi

**2.4 Connection between Control Panel and Robot**

Three types of cables were used to connect the control panel and the robot which are LAN (Local Area Network) cable, power cable and RCA (Radio Corporation of America) cable. Due to long distance command signal transmission, a LAN cable is used alongside with UDP (User Datagram Protocol) to preserve the data quality. RCA cable which is also known as Radio Corporation of America cable, commonly referred as A/V (Audio and Video) wire is used to transmit the video signals back to the display monitor.

**2.5 Mobile Inspection Robot Unit**

A Rover 5 tank tread robot is selected as the robot base since the tank tread type of navigation base is suitable to navigate inside a duct, despite the small obstacles that might obstruct the robot's path. Additionally, the robot is also equipped with a mechanical gripper or a brush depending on the situation to retrieve a substance inside the duct or clean the inner duct if necessary.

A Raspberry Pi and Raspberry Pi Camera Module is used as the microcontroller for the robot due to its small size and support for camera interface. To start off with the robot programming, the program flow chart has to be designed first. Figure 6 shows the robot operating flow chart.

The Raspberry Pi is a credit card sized single board computer. It has 8 pins of General Purpose Input or Output (GPIO) and 1 pin of Pulse Width Modulator (PWM) output. In this project, 5 PWM pins are required to control motors and servo motors. Servo motors

usually recognize the PWM output signal with 20 millisecond of period or in another words 50 Hz of frequency. Hirst [10] wrote a software named ServoBlaster to allow Raspberry Pi to have software PWM pins by invoking the kernel of the operating system to create a stable and accurate output of PWM. ServoBlaster is able to support up to a maximum 8 software PWM pins out of all of the GPIO pins [11].

The Raspberry Pi Camera Module is able to capture still images, and also record high definition video. These features are supported by the built in Application Programming Interface (API) in order to capture still images or video with high resolution or high frame rate, which requires a high performance of conversion from raw data into viewable image. There are three ports, namely the still port, the video port and the preview port. In order to permit simultaneous video recording and image capture via the video port, a "splitter" component is permanently connected to the video port, and an encoder is attached to one of the splitter output ports. However, in this project, the raw images are taken directly from the preview port and then stored into the program data buffer. To display the frames per second of the video displaying and its resolution, overlay text information is then embedded on top of the raw images previously and displayed onto the screen. The process of display live stream video is shown in Figure 7 [12].

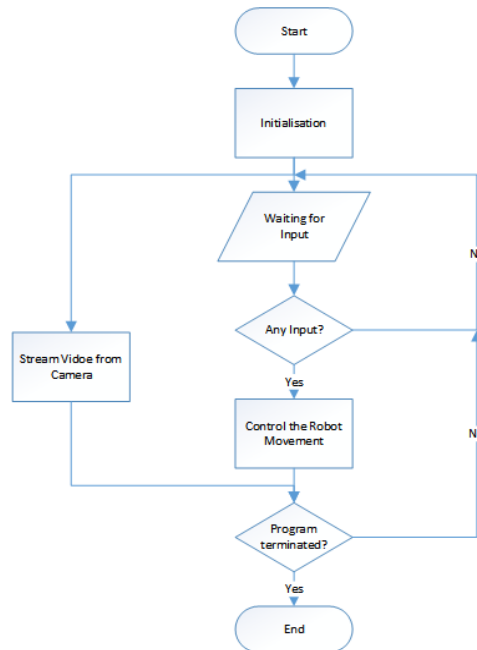

Figure 6 Robot program flow chart

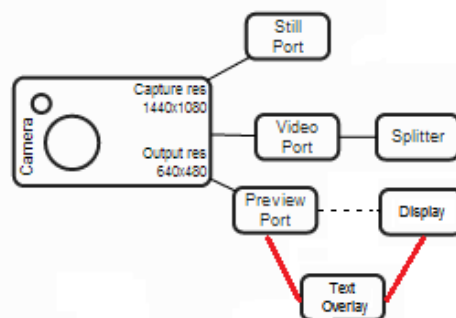

Figure 7 Setup for live stream video

### 3.0 RESULT AND DISCUSSION

#### 3.1 Mobile Inspection Robot for HVAC Ducting System

The robot preparation finished in 3 months with proper planning. The overall system of the Ducting Inspection Robot is shown in Figure 8. The actual design of the ducting inspection robot is shown in Figure 9. Figure 10 shows the mobile inspection robot with 2 kg of add-on mass.

**Table 1** Average Velocity of the Robot against Add-On Mass

Mass, <i>m</i> (kg)	Time Taken, <i>t</i> (s)			Average Time, <i>t</i> (s)	Average Velocity, <i>v</i> (m/s)
	1 <sup>st</sup>	2 <sup>nd</sup>	3 <sup>rd</sup>		
0	3.28	3.22	3.10	3.20	0.47
1	3.06	3.20	3.10	3.12	0.48
2	3.41	3.36	3.25	3.34	0.45
3	3.19	3.22	3.31	3.24	0.46
4	3.22	3.26	3.27	3.25	0.46

The inspection robot has two accessories, mechanical gripper and brush (Figure 11), so the user can choose which to equip it with. The actual structure of the gripper and brush is shown in the Figure 10.

The LED headlights were also tested inside the duct. The images were captured to compare the differences between with and without headlights from the robot vision. The comparison is shown in Figure 12.

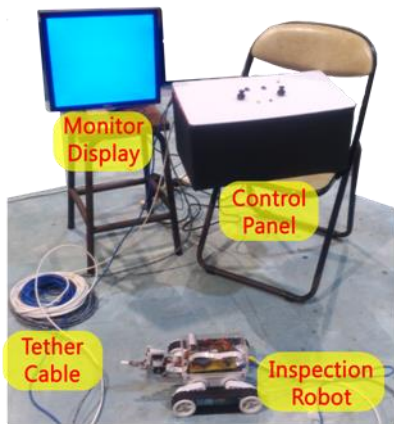

**Figure 8** Mobile inspection robot for HVAC ducting system

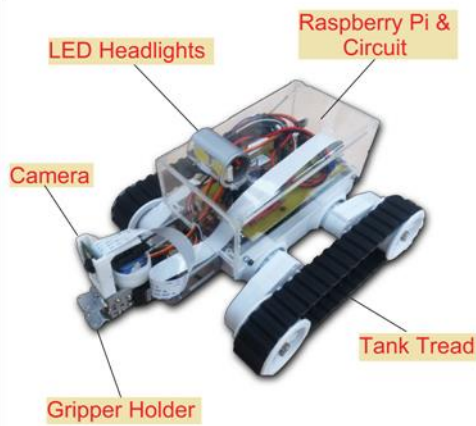

**Figure 9** System of mobile inspection robot for HVAC ducting system

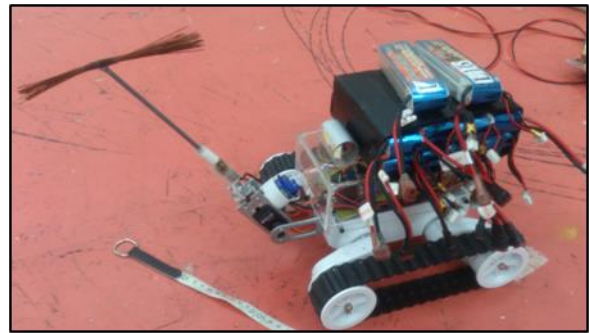

**Figure 10** The mobile inspection robot with 2 kg of add-on mass

#### 3.2 Experimental Result

To analyze the forward force of the mobile inspection robot produced by the DC motor to travel a far distance, an experiment of mass carrying of the robot was carried out. Wires connecting the robot and the control panel may be a burden for the robot since the robot is wired. Therefore, from the experiment done, it is possible to identify the forward speed of the robot against the add-on mass carried.

The robot itself has a mass of approximately 1.2 kg. The experiment was done by putting add-on mass on the robot and recording the time taken for the robot to travel for 1.5 meter while supplying 12 volts to the motors. The add-on mass ranged from no load until 4kg. The following figures show the setup of the experiment. The setup of the experiment is shown in Figure 13.



**Figure 11** Mechanical gripper and brush

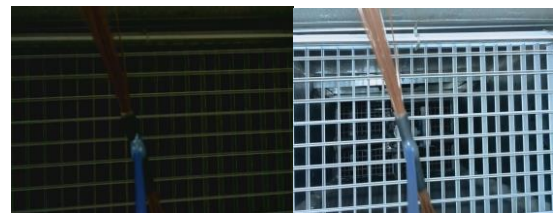

**Figure 12** Without LED headlights illumination (Left) and with LED headlights illumination (Right)

From the above experiment, three time trials were taken with the varied weights. The results taken are shown in the Table 1. The experiment with different add-on mass was repeated three times to minimize human error.

The result taken from the table was analyzed. The mean, variance and standard deviation of the robot speed with different add-on mass were calculated. It can be said that with the increasing of the add-on mass, the velocity of the mobile robot does not



change very much with a mean of 0.464ms<sup>-1</sup> from (1) until (3), variance of 0.000104 which is very little and standard deviation of 0.0102 from (4) until (7).

The average velocity of the robot is almost the same and therefore it is able to be concluded that the DC geared motor of the mobile inspection robot is able to carry up to 4kg of mass without affecting its forward velocity. Hence, travelling a far distance inside a duct with wires connected is not a problem for the mobile inspection robot.

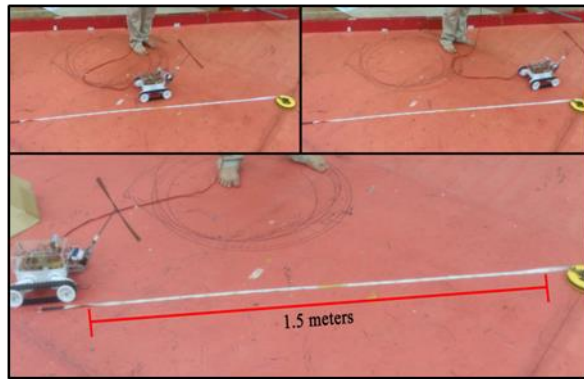

Figure 13 experiment of robot forward speed against add-on mass carried

## 4.0 CONCLUSION AND RECOMMENDATIONS

### 4.1 Conclusion

The robot is able to give forward vision feedback to the user. Additionally, the robot is also able to be attached with gripper and brush so that the robot is able to retrieve hazardous or suspicious items from the duct, and is also able to clean the duct if necessary. The robot is also able to assist in overcoming the unnoticed health issues caused by dirt and dust in most buildings with an HVAC system. However, even with the usefulness of its current form, the development of the robot should be continued to have better functionality.

### 4.2 Recommendations

Recommendation for future work in which this system can be improved is in terms of control delay for the robot movement. The python script it now uses does not really have a fast processing speed, therefore causing a slight delay while controlling the movements of the arms and base movement of the robot. The solution for this can be porting the current codes into C-programming language for better performance. At present, the robot does not support video recording during inspection. It is

strongly recommended to upgrade the software to add in the video recording feature. Finally, the robot structure for now is not properly designed for industrial purposes. Hence, it has to be redesigned appropriately, which would allow a more robust robot structure to work in the duct environment.

## Acknowledgement

The authors would like to acknowledge the Ministry of Education (MOE) Malaysia and Universiti Teknologi Malaysia, Research University Grant Scheme GUP (Vote No: 08J52), PAS (Vote No: 00K04) and Flagship RG Grant (Vote No: 02G10).

## References

- [1] B. A. Northrop and M. T. Phillips. 1994. Is Work Killing You? - Don't Let It. In *Professional Communication Conference, 1994. IPCC '94 Proceedings. Scaling New Heights in Technical Communication, International*. 432–437.
- [2] W. Moczulski, M. Adamczyk, P. Przystalka, and A. Timofiejczuk. 2007. Mobile Robot for Inspecting Ventilation Ducts. In *Recent Advances in Mechatronics*, R. Jabłoński, M. Turkowski, and R. Szweczyk, Eds. Springer Berlin Heidelberg, 47–51.
- [3] L. Sehulster and R. Y. W. Chinn. 2003. Guidelines for Environmental Infection Control in Health-Care Facilities. Division of Healthcare Quality Promotion National Center for Infectious Diseases, HICPAC Member, Sharp Memorial Hospital San Diego, California, United States of America.
- [4] J. Seung Woo, J. Wootae, P. Duckshin, and K. Soon-Bark. 2012. Design of an Intelligent Duct Cleaning Robot with Force Compliant Brush. In *Control, Automation and Systems (ICCAS), 2012 12th International Conference on*. 2033–2037.
- [5] W. Neubauer. 1994. A Spider-Like Robot That Climbs Vertically In Ducts or Pipes. In *Intelligent Robots and Systems '94. 'Advanced Robotic Systems and the Real World', IROS '94. Proceedings of the IEEE/RSJ/GI International Conference on*. 2: 1178–1185.
- [6] R. Neves and A. C. Matos. 2013. Raspberry PI Based Stereo Vision for Small Size ASVs. In *Oceans - San Diego, 2013*. 1–6.
- [7] M. Zolkapli, S. A. M. Al-Junid, Z. Othman, A. Manut, and M. A. Mohd Zulkifli. 2013. High-Efficiency Dual-Axis Solar Tracking Development using Arduino. In *Technology, Informatics, Management, Engineering, and Environment (TIME-E), 2013 International Conference on*. 43–47.
- [8] (2015, 15/01). *Arduino Uno*. Available: <http://arduino.cc/en/Main/ArduinoBoardUno>.
- [9] J. Hau-Shiue and L. Kai-Yew. 2013. Design and Control of a Two-Wheel Self-Balancing Robot using the Arduino Microcontroller Board. In *Control and Automation (ICCA), 2013 10th IEEE International Conference on*. 634–639.
- [10] R. Hirst. (2013, 15/01). *ServoBlaster*. Available: <https://github.com/richardghirst/PiBits/tree/master/ServoBlaster>.
- [11] (2015, 15/01). *Raspberry Pi*. Available: <http://www.raspberrypi.org/>.
- [12] D. Hughes. (2015, 15/01). *Camera Hardware*. Available: <http://picamera.readthedocs.org/en/release-1.9/>.