

Fundamental Sensor Development in Electrical Resistance Tomography

Ling En Hong^{a*}, Ruzairi Hj. Abdul Rahim^a, Anita Ahmad^a, Mohd Amri Md. Yunus^a, Khairul Hamimah Aba^a, Leow Pei Ling^a, Herman Wahid^a, Nasarudin Ahmad^a, Mohd Fadzli Abd Shaib^{a,b}, Yasmin Abdul Wahab^{a,c}, Suzanna Ridzuan Aw^{a,d}, Hafiz Fazalul Rahiman^e, Zulkarnay Zakaria^f

^aProtom-i Research Group, Infocomm Research Alliance, Control and Mechatronic Engineering Department, Universiti Teknologi Malaysia, 81310 UTM Johor Bahru, Johor, Malaysia

^bFaculty of Electrical and Electronic Engineering, Universiti Tun Hussein Onn Malaysia, 86400 Parit Raja, Batu Pahat, Johor, Malaysia

^cDepartment of Instrumentation & Control Engineering (ICE), Faculty of Electrical & Electronic Engineering, Universiti Malaysia Pahang, 26600, Pekan, Pahang, Malaysia

^dFaculty of Electrical & Automation Engineering Technology, Terengganu Advance Technical Institute University College (TATIUC), Jalan Panchor, Telok Kalong, 24000, Kemaman, Terengganu, Malaysia

^eSchool of Mechatronic Engineering, Universiti Malaysia Perlis, Pauh Putra Campus, 02600 Arau, Perlis, Malaysia

^fTomography Imaging Research Group, School of Mechatronic Engineering, Universiti Malaysia Perlis, 02600 Arau, Perlis, Malaysia

*Corresponding author: ling_enhong@yahoo.com

Article history

Received : 15 August 2014
 Received in revised form :
 5 January 2015
 Accepted : 10 February 2015

Graphical abstract

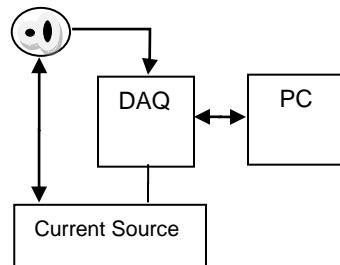

Abstract

This paper will provide a fundamental understanding of one of the most commonly used tomography, Electrical Resistance Tomography (ERT). Unlike the other tomography systems, ERT displayed conductivity distribution in the Region of Interest (ROI) and commonly associated to Sensitivity Theorem in their image reconstruction. The fundamental construction of ERT includes a sensor array spaced equally around the imaged object periphery, a Data Acquisition (DAQ), image reconstruction and display system. Four ERT data collection strategies that will be discussed are Adjacent Strategy, Opposite Strategy, Diagonal Strategy and Conducting Boundary Strategy. We will also explain briefly on some of the possible Data Acquisition System (DAQ), forward and inverse problems, different arrangements for conducting and non-conducting pipes and factors that influence sensor arrays selections.

Keywords: Electrical resistance tomography; region of interest; data acquisition system; data collection strategies; forward and inverse problem; sensor and development

© 2015 Penerbit UTM Press. All rights reserved.

1.0 INTRODUCTION

Industrial process tomography (IPT) is generally a cross sectional imaging of parameters of industrial processes and usually a function of time [1]. In IPT, the three classifications of sensor systems are transmission mode, reflection mode and emission mode techniques [2] and the four typical tomography section are sensor array, data acquisition system, image reconstruction and display system [3, 4] as shown in Figure 1.

However, one should always remember that in real industrial and research application, it is possible to implement combinations of stated sensors or known as multi-modality. For example, Deng [5] has used (i) Electrical Resistance Tomography (ERT) with electromagnetic (EM) flowmeter (ii) Electrical Capacitance Tomography (ECT) with ERT and (iii) ECT with electrostatic sensor for two phase flow measurement.

On the other hand, an example of such industrial application is a dual-modality ECT and ERT by Industrial Tomography System [6] that is able to visualize water and sand flow as well as oil and gas flow.

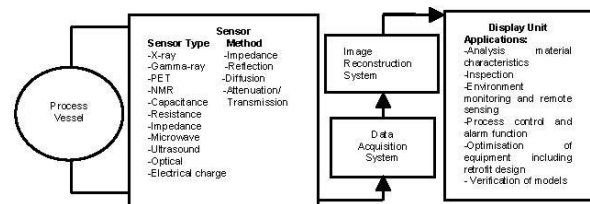

Figure 1 Block diagram of typical tomography system [3, 4]

In this paper, only the concept in ERT will be elaborated. The sections are divided into 1.0 Introduction, 2.0 Brief Background on ERT, 3.0 Design Principles where the operating principle of ERT which includes Data Collection Strategies of Adjacent Strategy, Opposite Strategy, Diagonal Strategy and Conducting Boundary Strategy; possible Data Acquisition System (DAQ) sample; forward problem and the Sensitivity Theorem. 4.0 Development of a resistance sensor which will incorporate difference of a conducting and non-conducting pipe as well as the factor considerations in designing the sensor array. 5.0 Conclusion

2.0 BRIEF BACKGROUND ON ERT

Since 1920s, resistivity imaging was widely accepted by geophysicists who inserted arrays of metallic electrodes into the ground in [7]. Today, the technique has been used in various industry which includes geology e.g to detect subsurface voids, by looking at an application to a tunnel [8], construction industry e.g to detect concrete crack using three dimensional [9], forestry industry e.g. to detect fungal decay in living trees [10], oil and gas industry e.g. to obtain data on the conductivity distribution of oil/water mixture flow at different depths[11], manufacturing includes food industry i.e to analysis of various milk solutions for quantitative auditing and attaining informative data such as total solids and fat content at constant temperature in various stages of milk processing [12] and even in the medical industry [13].

In general, ERT is non-intrusive, non-radiate, online visual monitoring, low in cost and can provide two or three dimension information of the sensitive field in process devices [14], [15]. For resistive targets, no one system seems distinctly better than the other, except for cost of operations which would be lowest for the two-electrode array [16]. Several types of studies have been carried out for ERT system. For instance, studies were carried out to find out the efficacy of one array over the other one using physical model studies. In this matter, it is found that the two electrode array as compared to the dipole-array, spacing to spacing (L) gives better response with respect to amplitude and shape of anomaly, depth of detection and cost of operation. The dipole array is better in shape and amplitude when the spacing (L) between the farthest moving active electrodes in an array is not considered as a yardstick for comparison, and the availability of the source power is not a problem in the field. It requires less cable and does not need the infinite cable lay-out.

Some of the advantages of ERT compared to some other techniques in real life application such as in the production logging (PL) for instance includes (i) unlike the statistics-based techniques, ERT can obtain the data on conductivity distribution over the whole cross-section of the pipe-line, (ii) as the imaging process is real-time and continuous, every single oil drop that flows through the imaging cross-section can be detected, and (iii) the information on oil drop distribution can be presented in a visible manner through image reconstruction [11]. A typical ERT system consisted of a sensor array equally spaced around the object periphery being imaged, a Data Acquisition System (DAQ) and a computer [17].

3.0 DESIGN PRINCIPLES

3.1 Operating Principle of Electrical Resistance Tomography and Data Collection Strategies

Electrical Resistance Tomography (ERT) is based on concept where different medium will not have a similar conductivity [18]. This means when the conductivity distribution of sensing field is obtain, the medium distribution of measured field can be identified. Block Diagram of a typical ERT System is as shown in Figure 2.

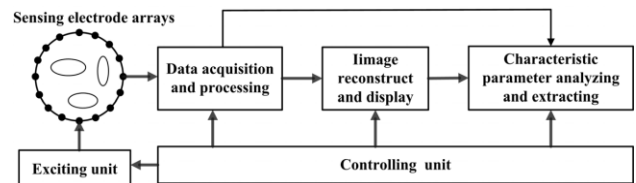

Figure 2 Block Diagram of a typical ERT System [14]

In this section, four different types of data collection strategies will be discussed which is (i) The Adjacent Strategy (ii) The Opposite Strategy (iii) The Diagonal Strategy and finally (iv) The Conducting Boundary Strategy.

In the adjacent sensing strategy used by Chao Tan, 2013, as shown in Figure 3, the exciting current was initially injected into a pair of electrodes and voltages are measured from successive pairs of neighboring electrode. The process is then repeated by inserting current to the next pair of electrodes and the voltage measurements taken until all independent measurement taken [18]. This strategy results in N^2 measurements, $N(N-1)/2$ independent measurement and in consideration of electrode/electrolyte contact impedance problems, voltage at current-injecting electrode is not included and further reduce to $N(N-3)/2$ where N is the number of electrodes [7].

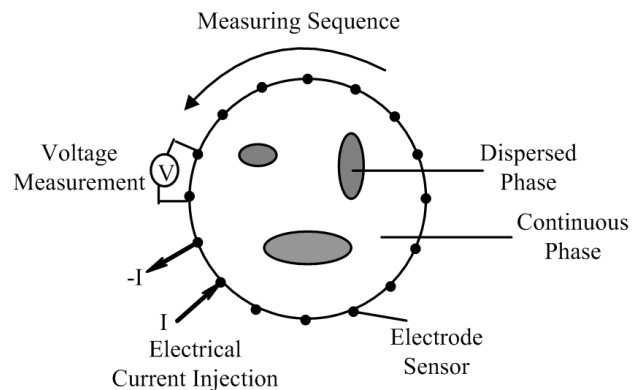

Figure 3 Operating principle of adjacent strategy ERT, Chao Tan, 2013 [18]

The disadvantages of the adjacent strategy is current distribution is non-uniform due to most of the current travels near the peripheral electrodes. This will cause high interference of measurement error and noise due to the lower current density at the centre of the vessel [19]. Secondly, it requires a minimal hardware capacity but is that requirement is meet, image reconstruction can be done relatively fast [20].

The exciting current, distribution of conductivity and electric potential are related by the Laplace Equation [18]:

$$\begin{aligned} \nabla \cdot (\sigma \cdot \nabla \phi) &= 0 && \text{in sensing field} \\ \int_{E+} \sigma \cdot \frac{\partial \phi}{\partial \vec{n}} d\vec{S} &= +I && \text{current in flow} \\ \int_{E-} \sigma \cdot \frac{\partial \phi}{\partial \vec{n}} d\vec{S} &= -I && \text{current out flow} \end{aligned}$$

where \vec{n} is the outer normal vector of each point at the boundary of the sensing field, E is electric field intensity, σ is the electrical conductivity, ϕ is the distribution of electric potential and I is the exciting current.

In order to simplify analysis of higher number of data, one can be compressed a frame or cross-sectional image into one feature or a vector of features [21]:

$$V_{Ri} = \frac{1}{N_j} \sum_{j=1}^{N_j} (V_{ij} - V_{oj}) \quad \text{Equation (1)}$$

where V_{Ri} is the simple feature, N_j is the number of data from a frame, V_{ij} is the measured value of the j th ($j = 1, 2, \dots, N_j$) boundary voltage in the i th frame, and V_{oj} is the measured voltage of the j th boundary voltage when the pipe is full of liquid measured.

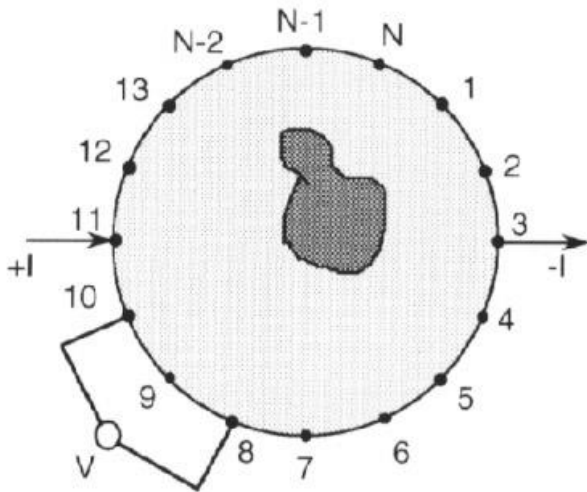

Figure 4 The opposite measurement strategy [7]

In the Opposite Strategy, current is applied through diametrically opposed electrodes as shown in Figure 4 [7]. The measured voltage of the electrode adjacent to the current-injecting electrode is known as voltage reference. The voltages are measured with respect to the reference at all the electrodes for a particular pair of current-injecting electrodes except the current-injecting ones. The voltage reference electrode is changed accordingly when the rest of the data set is obtained via switching the current to the next pair of opposite electrodes in the clockwise direction. The disadvantages of Opposite Strategy is less sensitive to conductivity changes at the boundary relative to the Adjacent Strategy considering most of the current flows through the central part of the region and the for same number of electrodes N , the number of independent current projections

applicable is significantly less than the same mentioned method but is countered by the fact that it has quite a good distinguishability as the currents are evenly distributed [19]. The number of Independent Measurements M is given by Equation 2 [22]:

$$M = \frac{N}{4} \left(\frac{3N}{2} - 1 \right) \quad \text{Equation (2)}$$

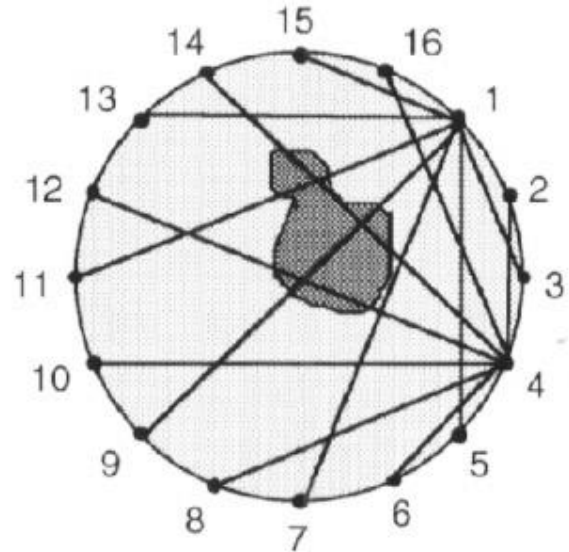

Figure 5 The diagonal measurement strategy

The Diagonal Strategy or The Cross Method is where currents are injected between electrodes separated by large dimensions as shown in Figure 5 [19]. This produces a more uniform current distribution in the region of interest as compared to Adjacent Strategy. The way the method operates can be visualized in the following example. By using a 16-electrode ERT as an example, electrode 1 is fixed as a current reference and electrode 2 as the voltage reference. Later, the current is applied successively to electrodes 3, 5, ..., 15. The voltages from all electrodes except the current-injecting ones are measured with respect to electrode 2 for every current pair. Electrode 4 is then current reference while Electrode 3 becomes voltage reference. This sequence will be repeated. Voltage will always be measured on all other electrodes except the current-injecting ones. In the example of 16 – electrode ERT, 91 data points will be obtained from 13 voltage measurements and 7 independent current electrode pairs for each pair of current electrodes. The total would provide 182 data points and 104 are independent. This method has the benefit of better matrix conditioning and sensitivity over the entire region and is not as sensitive to measurement error relative to Adjacent Method and thus produces better quality but has a disadvantage of lower sensitivity in the periphery relative to the same reference.

The Conducting Boundary Strategy is a measurement strategy used on process vessels and pipelines with electrically conducting boundaries as shown in Figure 6 [23]. The strategy used only two electrodes for measurement. Larger surface area of the conducting boundary is used as the current sink to reduce the common-mode voltage across the measurement electrodes. Therefore, common-mode feedback and earthed (load) floating measurement techniques is not required. The effect of electromagnetic interference is also reduced via the earthed conducting boundary. The method has 800 times lower

common-mode voltage components and a factor of seven lower regarding the amplitude of the measured voltages for identically shaped process vessels relative to the Adjacent Strategy.

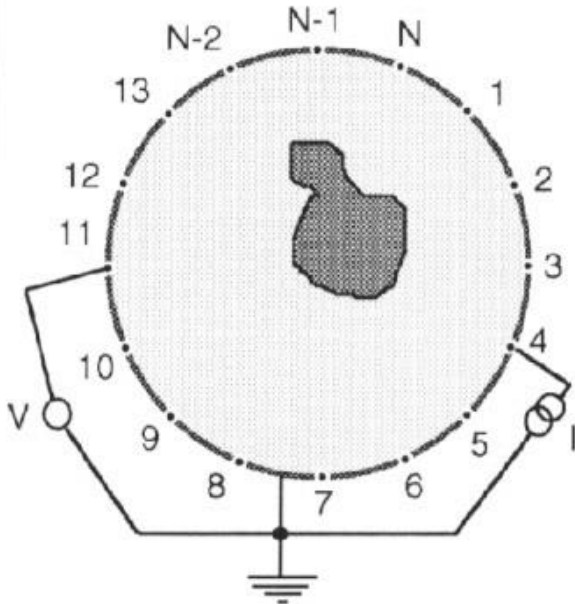

Figure 6 The conducting boundary measurement strategy [23]

3.2 ERT Data Acquisition System

Generally, Data Acquisition Systems are devices that interface between the real world of physical parameters which are analog with the artificial world of digital computation and control [24]. Data converters on the other hand are devices that perform the interfacing function between analog and digital worlds in which comprises of analog-to-digital (A/D) and digital-to-analog (D/A) converters. The basic DAQ may employ at least one of the circuit functions i.e data converters, transducers, amplifiers, filters, nonlinear analog functions, analog multiplexers and sample-holds.

The general principle of operation of a Data Acquisition System started with the physical parameter input such as pressure and flow which are analog quantities converted to electrical signals via a transducer [24]. An amplifier will then boost the amplitude of the transducer output signal to a useful level for further processing. The output of the transducer may be microvolt or millivolt level signals which are then amplified to 0V to 10V levels.

Furthermore, the transducer output may be a high impedance signal, a different signal with common-mode noise, a current output, a signal superimposed on a high voltage or a combination of these. In most cases, the amplifier will be followed by a low-pass active filter that reduces or eliminate high-frequency signal components, a noise. At times, the amplifier is followed by a special nonlinear analog function circuit that performs a nonlinear analog function circuit that performs a nonlinear operation on the high level signal which includes squaring, multiplication, division, rms conversion, log conversion or linearization.

Next, analog multiplexer which switches sequentially between a number of different analog input channels [24]. Each input is in turn connected to the output of the multiplexer for a specified period of time by the multiplexer switch. A sample-hold circuit acquires the signal voltage and then holds its value

during this time while an A/D converter converts the value into digital form. The resultant digital word goes to a computer data bus or to the input of a digital circuit. The analog multiplexer and the sample-hold time shares the A/D converter with a number of analog input channels. A programmer-sequencer will be controlling the entire DAS and timing. One can also carry out low-level multiplexing with the amplifier instead of high-level signals where only one amplifier is needed but the gain have changed to the next channel. Besides that, one can also amplify and convert the signals into digital form at the transducer location and send the digital information in serial form to the computer. The digital data must be converted to parallel form and then multiplexed onto the computer data bus.

In this section, we will be discussing on possible structure of ERT Data Acquisition (DAQ):

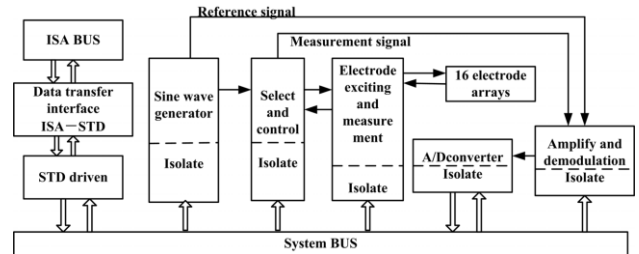

Figure 7 ERT Data acquisition system [14]

Dong [14] in 2007 has explained the existing ERT Data Acquisition prior to his proposed improvement as shown in Figure 7. They have used 16 electrode system as an example. The computer communicates with the system via system bus and gives the needed controlling signals. In the system, AD converter is a 12 bit serial-out ADC chip. The speed of the DAQ was about 40 frame / second. The drawback of stability and reliability is from the uses of many dissociation elements, the connections between the elements are very complicated and are not stable. This will lead to debugging difficulties and carrying out experiments.

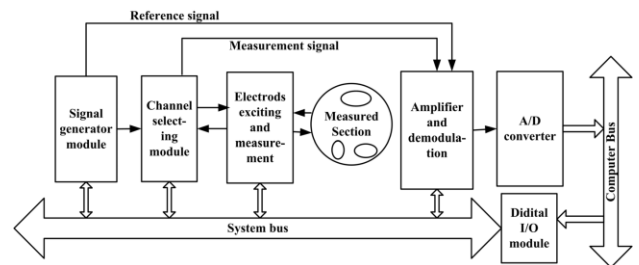

Figure 8 Improved ERT data acquisition system [14]

Due to these reasons, there are many opportunity for improvement on Data Acquisition System alone. An improvement has been done by the same author on the speed, stability, and reliability as shown in Figure 8. The way the system works as follows. Firstly, the computer initializes the system through digital I/O card PC7501, writes the sine-wave generator to generate the sine wave, selects the electrodes accordingly to a certain exciting strategy, current is applied through two neighboring electrodes and the voltages measured from successive pairs of neighboring electrodes. Current is then applied through the next pair of electrodes and the voltage

measurement is repeated until all independent measurements are done. The measured signals are amplified, demodulated, passed through a low-pass filter to eliminate high frequency signals, through a A/D converter for conversion to digital signals and stored in the computer for subsequent processing.

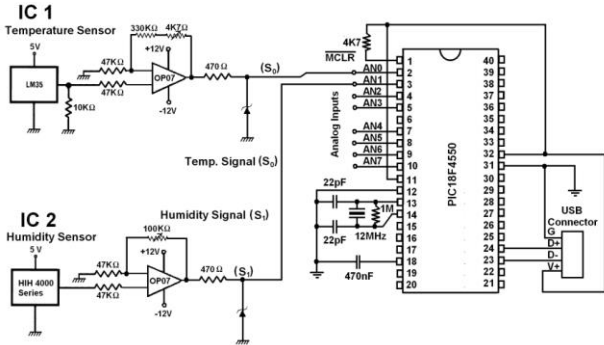

Figure 9 Circuit diagram of the data acquisition system [25]

Today's Data Acquisition (DAQ) could be based on many technologies. Monoranjan Singh [25] has used PIC18F4550 microcontroller to design and developed a low cost Universal Serial Bus (USB) Data Acquisition System for the measurement of physical parameters such as temperature which are relatively slow varying signals are sensed by respective sensors or integrated sensors and converted into voltages. The designed is online monitoring developed via Visual Basic. The circuit diagram can be seen as in Figure 9. Some of the other components that are used includes temperature sensor LM35 which is pre calibrated in degree Celsius, humidity sensor HIH4000, signal conditioning using OpAmps OP07 and a 5.1 volt zener diode as a over voltage protector. The system has 10 bit resolution with an accuracy of 4.88mV (0.0977%).

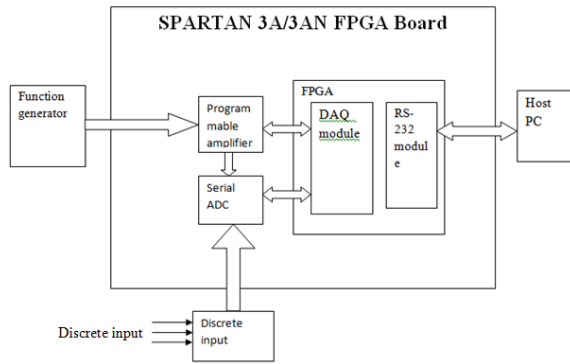

Figure 10 DAQ in Spartan 3A/3AN FPGA Board [26]

Besides microcontroller based, other technology that can be used to design Data Acquisition System includes Field Programmable Gate Array (FPGA). Swamy [26] as shown in Figure 10 has designed and implement a data acquisition system (DAQ) by using serial RS-232 and SPI communication protocols on FPGA platform which is able to acquire analog and digital signals. Their choice of programming language is VHDL. Some of the components used includes 14 bit LTC1407A-1 as serial ADC and LTC6912-1 as the pre-

amplifier. In real time application, the author uses signal conditioner instead of function generator. Overall, the system performs data rate of 1.5Msp/s and high accuracy of about 99%.

3.3 Forward Problem in the Image Reconstruction

Once the electrical field exciting frequency is fixed, the only contributor to the measured value of resistance between an electrode pairs is the distribution of the conductivity in the ROI [11]. Assumption can thus be made the relationship between the measured resistances R and the conductivity distribution in the ROI, σ is given by Equation (3):

$$R = F(\sigma) \tag{Equation 3}$$

which could become Equation (4) by Taylor series expansion at a local point,

$$R = R_0 + \frac{dF}{d\sigma}(\Delta\sigma) + o[(\Delta\sigma)^2] \tag{Equation 4}$$

where $(dF/d\sigma)(\Delta\sigma)$ is the sensitivity of the resistance versus the conductivity and $o[(\Delta\sigma)^2]$ is the higher order infinitesimal of $(\Delta\sigma)^2$. The equation could be rewrite into:

$$\Delta R = \frac{dF}{d\sigma}(\Delta\sigma) + o[(\Delta\sigma)^2] \tag{Equation 5}$$

where $\Delta R = R - R_0$, $o[(\Delta\sigma)^2]$ can be neglected due to the assumption $\Delta\sigma \approx 0$ and become Equation (6)

$$\Delta R = s \Delta\sigma \tag{Equation 6}$$

where $s = dF/d\sigma$ is the sensitivity of the measured resistance changes versus the conductivity changes in the ROI.

The ROI is uniformly divided into N small pixels with different sensitivity coefficients to visualize the conductivity distribution.

Thus, with different electrode pairs selected to be in excitation and measurement, the value of sensitivity coefficient at each pixel will change respectively.

Next, Equation (6) has to be discretized into Equation (7) to reconstruct a cross-sectional image.

$$\Delta R_D = J_D \Delta\sigma_D \tag{Equation 7}$$

M x 1 M x N N x 1

where J_D is the discrete form of the Jacobin matrix or the sensitivity matrix.

Equation (7) can be represented as Equation (8) to visualize the conductivity distribution in the ROI.

$$z = S g \tag{Equation 8}$$

M x 1 M x N N x 1

where z is an M x 1 vector containing the measured resistance data, ΔR_D (in Equation (7)), g is the N x 1 gray level vector, $\Delta\sigma_D$ (in Equation (7)), S is M x N sensitivity matrix, J_D (in Equation (7)) that contains M sensitivity maps.

3.4 Operating Principle of Image Reconstruction Algorithm

Image Reconstruction process is the Inverse problem. The most common image reconstruction algorithm for ERT is Sensitivity Theorem or also known as Lead Theorem. Geselowitz [27] and later refined by Lehr [28] have introduced a clear analysis of the boundary mutual impedance suffered by the changes of conductivity inside a domain. The basic theorems of Sensitivity Theorem are Green’s Theorem and the Divergence Theorem. From these two basic theorem, the Reciprocity Theorem and the Lead Theorem of Mutual Impedance Z can be derived (as shown in Figure 11).

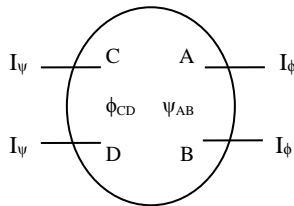

Figure 11 Terminology, Wang et al. 1999 [29]

$$I_\phi \psi_{AB} = I_\psi \phi_{CD} \quad \text{Equation (9)}$$

$$Z = \frac{\phi_{CD}}{I_\phi} = \frac{\psi_{AB}}{I_\psi} \quad \text{Equation (10)}$$

where ψ_{AB} , ϕ_{CD} are potentials measured from ports A – B and C – D in response to currents I_ψ and I_ϕ respectively.

Besides that, the Reciprocity Theorem shows the total number of all possible unique measurement at $N(N + 1)/2$.

The quantitative algorithm is more critical to qualitative algorithm in terms of the electrodes equi-distance positioning as the data are not normalized prior to reconstruction [20]

In the discrete form of the conductivity distribution of the ROI from the measured resistance vectors, the need to first find the unknown g from the known z using Equation (8) which can be directly solved if the inverse of S exists as shown in Equation (11) [11].

$$g = S^{-1} z \quad \text{Equation (11)}$$

where S is the pre-compute the sensitivity matrix

Due to an underdetermined problem in ERT and the inverse of S does not exist, other methods such as the Conjugate Gradient (GG), an iterative method could be used to solve.

4.0 DEVELOPMENT OF A RESISTANCE SENSOR

The first thing that one should know in the development of the ERT sensor is to understand the theory or concept behind ERT. In ERT systems, the sensors must be in continuous electrical contact with the electrolyte inside the process vessel [7] and more conductive than the electrolyte in order to obtain reliable measurements. An important attention needs to be taken on the different way of installing metal electrode on metal pipe and non-conducting pipe considering to the measurement that is taken is the resistance.

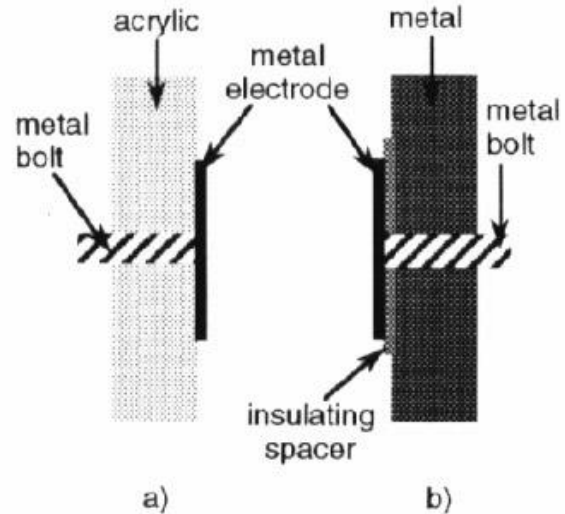

Figure 12 Difference in arrangement between electrode installations to a non-conducting (a) and conducting pipe (b) [7]

In Figure 12, a commonly non-conducting pipe e.g. acrylic and an electrically conducting metal pipe e.g. steel is used to illustrate the arrangement. The primary reason for this arrangement (b) is to eliminate the direct short-circuits contact between two conducting materials, i.e. metal electrode and pipe. The insulating spacer should be very much wider and taller than the electrode to mimic a non-conducting walled vessel but usually there will be a trade-off between spacer/electrode dimensions [7]. Besides that, one should consider the length of signal-carrying cable between the electrode and the current injection/voltage measurement circuitry when building the sensors into the vessel. Larger associated stray capacitance and current leakage which causes highly undesirable phase shifted signals could be caused by longer cable. In addition, electromagnetic interference from heavy duty electrical machinery could cause the cable acting like an antenna.

The key factors that should be considered in designing a sensor array includes the number of electrodes, the size of the electrodes, materials used to construct the sensor [17] and economic factor. Electrodes are usually made of metals [7]. The two factors considered in the material selection is obvious which is the electrical and chemical characteristics. Physical characteristics of the first two said considerations will need to meet practical implementation such as reduce the contact resistance between the electrode and the medium effectively and to improve the distribution of sensitivity field on the verge of flat field. The number of electrodes is a trade-off between image resolution and system complexity. A trade-off system will help to provide a certain desired outcome at the expense of other system factors. In the case of selecting the number of electrodes, higher quantity will lead to better spatial resolution as more measurements taken but would cause more current flow through the near field and lower sensitivity to the centre as a result of reduced distance between two adjacent electrodes. Since more measurement is taken, hardware requirement needs to increase accordingly in order to sustain the same real time performance. In real industrial application, the economic factor would be as important as the technical factor. Factors such as budget allocation, investment returns or cost justification on the application and lead time required to install an engineering system could not be neglected.

Table 1 Defined conductivities [11], [30]

Components	Defined Conductivity S.m ⁻¹
1. Groundwater (Fresh)	0.01 – 0.1
2. Salt Water	5
3. Oil Drops	10 ⁻¹⁰
4. Clay	0.01 - 1
5. Iron	1.102 x 10 ⁷
6. 0.01M Potassium Chloride	1.413
7. 0.01M Sodium Chloride	1.185
8. Xylene	1.429 x 10 ⁻¹⁷

There is a simple method that can be used to estimate the conductivity of a solid or liquid material. A megger, multimeter and test material is first connected in series. By injecting let say 250 V_{DC} or 500 V_{DC} from a megger, one can know the resistance of the material by obtaining the current that flow through the multimeter and by using Ohms Law. Conductivity is the reciprocal of resistance. For a solid, the conductivity per meter is easily obtained. The length of the material could be easily measured by the shortest distance of current flow taken between the shortest distance of probe between the megger and multimeter via the solid material. For liquid, it is a bit tricky. The resistance of the container for the liquid must first be measured. The two same probes must then inserted in the liquid and the calculated value of the resistance of the combined liquid and its container must be very much smaller than its container alone in order for the readings to be valid. Repeat the steps by using a different container (i.e material) if the combined resistance of liquid with its container is not very much smaller than the container alone. The length in this case is the straight distance between the tips of the two probes via the liquid. To obtain a more accurate value of conductivity per meter length, one should avoid locating the two probes connected directly to material measured to close to each other. Some of the defined conductivities is shown in Table 1.

■5.0 CONCLUSION

An overview concept of Electrical Resistance Tomography (ERT) has been elaborated comprises of the concepts, overall types of hardware and software available. The elaboration of different available types of data collection strategies and Data Acquisition System (DAQ) with their respective performance, strength and weaknesses is intended to provide insights when selecting the best system to meet individual cases and requirements. As in most engineering based solutions, selection decisions on designing ERT will always revolves around the trade-off principle to meet the most optimum solution required.

Acknowledgement

The author would like to thank UTM for given Zamalah Scholarship to the researcher and a Protom-i Research Group University of Universiti Teknologi Malaysia for the guidance in the preparation of this paper.

References

- [1] International Atomic Energy Agency. 2008. *Industrial Process Gamma Tomography: Final Report of A Coordinated Research Project 2003–2007*. Vienna, Austria.
- [2] N. Reinecke et al. 1998. Tomographic Measurement Techniques: Visualization of Multiphase Flows. *Chemical Engineering Technology*. 21: 7–18.
- [3] S. Ibrahim et al. 2000. *Modelling to Optimize the Design of Optical Tomography Systems for Process Measurement*. Symposium on Process Tomography. 18–19 May, Jurata.
- [4] S. Ibrahim et al. 2000. *Optical Tomography for Process Measurement And Control*. Control UKACC Int Conference. 4–7 Sept 2000, University of Cambridge.
- [5] X. Deng and W. Q. Yang. 2012. Fusion Research of Electrical Tomography with Other Sensors for Two-phase Flow Measurement. *Measurement Science Review*. 12(2): 62–67.
- [6] Industrial Tomography Systems. 2010. *An Oil Company Used Dual-modality ECT and ERT to Study the Flow of Multiphase Oil-water-gas Systems Reducing Energy Costs and Improving Plant Yields* [Annual Buyers' Guide 2010]. Reader Reply Card No 168.
- [7] F. Dickin and M. Wang. 1996. Electrical Resistance Tomography for Process Applications. *Meas. Sci. Technol.* 7: 247–260.
- [8] G. I. Riddle et al. 2010. ERT and Seismic Tomography in Identifying Subsurface Cavities, GeoConvention 10–14 May 2010, Calgary, Alberta, Canada. 1–4.
- [9] K. Karhunen et al. 2010. Electrical Resistance Tomography Imaging of Concrete. *Cement and Concrete Research*. 40: 137–145.
- [10] D. Bieker et al. 2010. Non-destructive Monitoring of Early Stages of White Rot by *Trametes Versicolor* in *Fraxinus Escelsior*. *Ann. For. Sci.* 67: 210p1–210p7.
- [11] H. Zhou et al. 2012. Image Reconstruction for Invasive ERT in Vertical Oil Well Logging. *Chinese Journal of Chemical Engineering*. 20(2): 319–328.
- [12] M. Sharifi and B. Young. 2012. Milk Total Solids and Fat Content Soft Sensing via Electrical Resistance Tomography and Temperature Measurement. *Food and Bioprocess Processing*. 90: 659–666.
- [13] M. Khanal and R. Morrison. 2009. Analysis of Electrical Resistance Tomography (ERT) data using Least-Squares Regression Modelling in Industrial Process Tomography. *Meas. Sci. Technol.* 20: 1–8.
- [14] F. Dong et al. 2007. Optimization Design of Electrical Resistance Tomography Data Acquisition System. Proceedings of the Sixth International Conference on Machine Learning and Cybernetics, 19–22 August, Hong Kong. 1454–1458.
- [15] L. Xu et al. 2002. The Applications in the Producing Process of the Electrical Resistance Tomography. *Journal of Northeastern University*. 21: Suppl. 1–5.
- [16] V. S. Sarma. 2014. Electrical Resistivity (ER), Self Potential (SP), Induced Polarisation (IP), Spectral Induced Polarisation (SIP) and Electrical Resistivity Tomography (ERT) prospection in NGRI for the past 50 years-A Brief Review. *J. Ind. Geophys. Union*. 18(2): 245–272.
- [17] F. Dong et al. 2012. Design of Parallel Electrical Resistance Tomography System for Measuring Multiphase Flow. *Chinese Journal of Chemical Engineering*. 20(2): 368–379.
- [18] C. Tan et al. 2013. Gas-Water Two-Phase Pattern Characterization with MultiVariate MultiScale Entropy. *IEE*.
- [19] P. Hua et al. 1993. Effect of The Measurement Method on Noise handling and image quality of EIT imaging. *IEEE 9th Annual Conf. on Engineering in Medicine and Biological Science*. 1429–30
- [20] Suzanna Ridzuan Aw, Ruzairi Abdul Rahim, Mohd Hafiz Fazalul Rahiman, Fazlul Rahman Mohd Yunus, Chiew Loon Goh. 2014. Electrical Resistance Tomography: A Review of the Application of Conducting Vessel Walls. *Powder Technology*. 254: 256–264, ISSN 0032-5910.
- [21] C. Tan et al. 2007. Identification of Gas/Liquid Two-Phase Flow Regime through Ert-based Measurement and Feature Extraction. *Flow Measurement and Instrumentation*. 18(5–6): 255–261.
- [22] W. R. Breckon and M. K. Pidcock. 1988. *Some Mathematical Aspects of EIT*. Mathematics and Computer Science in Medical Imaging ed M. A. Viergever and A E Todd-Pokropek. Berlin: Springer. 351–62.
- [23] M. Wang. 1994. *Electrical Impedance Tomography on Conducting Walled Vessels*. PhD Thesis UMIST.
- [24] G. Wöstenkühler. 2005. Data Acquisition Systems (DAS) In General, *Handbook of Measuring System Design*: John Wiley & Sons, Ltd
- [25] N. Monoranjan Singh et al. 2012. Design and Development of Low Cost Multi-Channel USB Data Acquisition System for the Measurement of Physical Parameters. *International Journal of Computer Applications*. (0975 – 888). 48(18): 47–51.
- [26] T. N. Swamy and K. M. Rashmi. 2013. Data Acquisition System based on FPGA. *International Journal of Engineering Research and Applications*. 3(2): 1504–1509.
- [27] D. B. Geselowitz. 1971. An Application of Electrocardiographic Lead Theory to Impedance Plethysmography. *IEEE Trans. Biomed. Eng.* BME-18: 38-41.

- [28] J. Lehr. 1972. A Vector Derivation Useful in Impedance Plethysmographic Field Calculations. *IEEE Trans. Biomed. Eng.* BME-19: 156–157.
- [29] M. Wang *et al.* Electrical Resistance Tomographic Sensing Systems for Industrial Applications. *Chemical Engineering Communications.* 175(1): 49–70.
- [30] R. Andrade. 2011. Intervention of Electrical Resistance Tomography (ERT) in Resolving Hydrological Problems of a Semi Arid. *Journal Geological Society of India.* 78: 337–344.