

# Fouling Evaluation for Ultrafiltration of Protein-based Washwater: A Resistance-in-series Model Approach

Diyana Kamarudin<sup>a</sup>, Nora'aini Ali<sup>a,c\*</sup>, Mahirah Ismail<sup>a</sup>, Norasikin Othman<sup>b,c</sup>

<sup>a</sup>School of Ocean Engineering, University Malaysia Terengganu, 21030, Kuala Terengganu, Terengganu, Malaysia

<sup>b</sup>Centre of Lipid Engineering and Applied Research, IBNU SINA ISIR, Universiti Teknologi Malaysia, 81310 UTM Johor Bahru, Johor, Malaysia

<sup>c</sup>Faculty of Chemical Engineering, Universiti Teknologi Malaysia, 81310 UTM Johor Bahru, Johor Malaysia

\*Corresponding author: noraaini@umt.edu.my

## Article history

Received : 2 March 2015  
Received in revised form :  
24 April 2015  
Accepted : 10 May 2015

## Graphical abstract

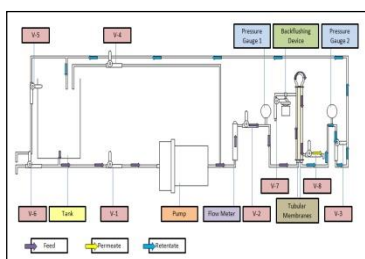

## Abstract

A comprehensive understanding of fouling mechanisms throughout the separation system process is crucial in designing a desired bio-separation system. In this research, we have adopted a resistance-in-series model to determine magnitude of four major resistances that govern in fouling mechanisms namely membrane hydraulic ( $R_m$ ), adsorption ( $R_{ad}$ ), pore plugging ( $R_{pp}$ ) and cake formation ( $R_c$ ) resistances. The experiments were conducted using a tubular ultrafiltration Polyvinylidene (PVDF) membrane with surimi wash water as model protein-solution. Two main operating parameters of trans-membrane pressure (TMP) and cross-flow velocity (CFV) were chosen to study the effects of operating conditions towards fouling mechanisms evaluated using resistance-in-series model. The resistance magnitudes were in the following sequence:  $R_{pp} > R_{ad} > R_c > R_m$ . The growth kinetics of each phase on resistances and the kinetic constants represent the extent of flux drop were quantified. Permeate obtained from the filtration process produced the clarified washwater with satisfactory quality physically and physico-chemically based water on national water quality standards.

**Keywords:** Biofouling; resistance-in-series-model; protein washwater; growth kinetics

© 2015 Penerbit UTM Press. All rights reserved.

## 1.0 INTRODUCTION

Resistance in series model, has been used in order to better understand biofouling. The model considers membrane resistance, adsorption resistance, pore plugging resistance and fouling resistance to describe the effect of operating parameters of surimi ultrafiltration (UF) process. Surimi washwater is the liquid waste obtained from surimi manufacturing process. Reported, at least 5000 tons (on a dry-mass basis) of sarcoplasmic proteins are estimated to have been lost to wash water during washing of the 200,000 tons of surimi that were produced in Japan in 1990 which believed worth huge amount of money if the proteins were fully recovered to be applied in other technologies and industries [1]. An ideal protein bioseparation process must combine high productivity with high selectivity of separation, and must be feasible at mild operating conditions. These entire requirements are met by ultrafiltration, which is a pressure-driven membrane-based separation process [2].

Membrane microfiltration and ultrafiltration are separation techniques that are currently used in many biotechnology, food, and pharmaceutical processes to purify, concentrate, or separate products within complex process streams [3]. The major drawback of membrane process is fouling. Since the launch of the

commercial membranes housed in membrane modules, manufacturers have been in constant process of improving the filtration characteristics of the membranes to mitigate the negative effects of fouling and loss of permeability; to enhance membrane application [4].

Fouling can be simply indicated by flux reduction. In most cases, flux decline in protein ultrafiltration is attributed to two main sources: concentration polarization and membrane fouling [5]. Flux decline in membrane filtration is a result of the increase of the membrane resistance and the development of another resistance layer, which can be elucidated in term of pore blockage and cake formation, respectively [6]. When a protein solution is pumped across the membrane surface, interaction between protein molecules and the membrane surface and inner pores may occur immediately due to the amphoteric nature of protein molecules and the hydrophobic nature of membrane material [6]. Resistance-in-series model simply describes that the flux decline is due to the combined effects of irreversible membrane fouling and reversible membrane fouling (concentration polarization) over the membrane surface in addition to the membrane resistance [7]. Thus, in this study, resistance-in-series model was adopted in ultrafiltration process because it is widely applied in the ultrafiltration of the mixtures of micromolecule solutes since

it is particularly applicable for the flux decline analysis in ultrafiltration and also microfiltration [8]. This paper describes the model used in quantifying fouling in term of resistance with the effects of operating conditions namely transmembrane-pressure (TMP) and crossflow-velocity (CFV).

## 2.0 EXPERIMENTAL

### 2.1 Materials

Protein-based washwater used in this study was laboratory prepared surimi washwater. The recovery of protein from surimi washwater was carried out for four different periods 30, 60, 90 and 120 minutes at temperature less than 36°C at average concentration of protein 350 ppm. The washwater was preserve at -20°C and was used within a month. It was characterized for several physicochemical properties namely–Biochemical Oxygen Demand (BOD), pH, Total Suspended Solids (TSS), Turbidity and Protein Content. Related properties of the surimi washwater were compared with national water quality standards.

### 2.2 Preparation of Protein-based Solution: *Pangasius sp.* Freshwater Fish

*Pangasius sp.* is a white flesh fresh water fish. It was selected as it contains considerably high protein contents that suitable for surimi industries. The fish was headed and gutted before fish flesh was separated from its bone and skin during deboned. The fish was minced and washed with icy water with ration of chilled distilled water (3): fish minced (1). The mixture of water and fish mince then was refined. Sodium Hydroxide (NaOH) 5.0 M and Chloric Acid (HCl) 5.0 M were be used to treat sample and maintained the sample pH at 6. The mixture was centrifuge at 3000g (g is Relative Centrifugal Force) for 6 minutes at 4°C. The supernatant obtained was accumulated and preserved as sample which was used as feed in the membrane separation system.

### 2.3 Membrane Filtration Apparatus

Experiments were carried out using tubular crossflow filtration mode, as shown in Figure 1. Commercial Tubular membranes made of polyvinylidene fluoride (PVDF) with molecular weight cut-off (MWCO) of 100 kDa, fibre diameter of 63.5 mm, flow length of 30 cm and effective area of 0.024 m<sup>2</sup> was employed.

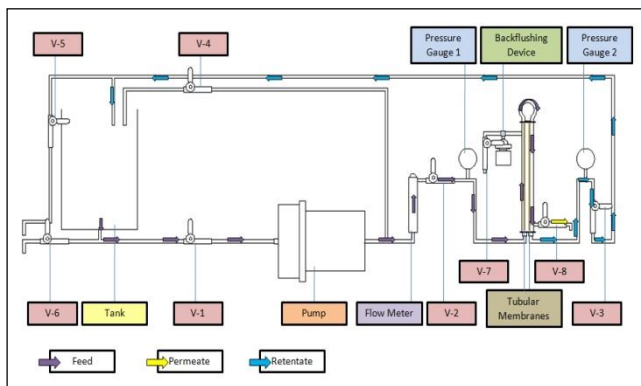

**Figure 1** Schematic diagram of tubular crossflow membrane filtration system

### 2.4 Calculation of Resistance Values

Flux decline in any membrane separation processes can be induced by resistances on the feed side of membrane film which include concentration polarization, solute adsorption, pore plugging and eventually cake formation. Resistance-in-series model take into consideration of the abovementioned resistances: membrane resistance, adsorption resistance, concentration polarization resistance and cake resistance. This model has been widely applied for the analysis of flux decline in ultrafiltration and microfiltration of the proteins-based solutes which contains many macromolecules such as surfactant micelles, proteins, polysaccharides and peptides. Based on resistance in series model, the values of each resistance for every fouling stage were quantified. In this study, an effort had been focused to quantify these resistances independently at different operating time points by conducting independent experiment. Eventually, correlations and interaction parameters were proposed for each of fouling stages and the growth of total resistance was calculated. The overall flux decline is presented by the following phenomenological equations:

$$J_w = \frac{\Delta P}{\mu (R_m + R_{ad} + R_{pp} + R_f)} \quad (1)$$

#### 2.4.1 Membrane Hydraulic Resistance ( $R_m$ )

The membranes were compacted through the filtration of distilled water under different pressure. The permeate flux was plotted against the operating pressure. The plots of  $J_w$  vs Pressure through origin will give the value of membrane permeability,  $L_p$ , which represented by the slope of straight line. The membrane hydraulic resistance was calculated from the following equation:

$$R_m = \frac{1}{\mu L_p} = \frac{\Delta P}{\mu v w} \quad (2)$$

#### 2.4.2 Adsorption Resistance ( $R_{ad}$ )

Adsorption of the membrane surface by solute particles is determined by membrane-solute interactions. The surimi wash water was loaded in the membrane system without applying any pressure yet for four different time durations, i.e. 30, 60, 90, 120 min. After a particular time interval, the cell was dismantled and the membrane was rinsed by distilled water several times such that loosely bound particles were washed off.

From the slope of the flux versus pressure, the resistance of the membrane was calculated in which  $R'_m$ , was the new membrane resistance.

$$R'_m = \frac{\Delta P}{\mu v_{ad}} \quad (3)$$

From Equation (3), the value for adsorption resistance was evaluated at the end of the particular time interval fixed which 30, 60, 90 and 120 minutes were. The values than determined by

$$R_{ad} = R'_m - R_m \quad (4)$$

#### 2.4.3 Pore Plugging Resistance ( $R_{pp}$ ) and Fouling Resistance ( $R_f$ )

Degree of pore plugging is mainly contributed by the relative size of the solute and membrane pore as well as the operating conditions. In this experiment, the sizes of the solutes are varied from macromolecules to small molecules, and the operating conditions that taken into account were TMP and CFV. These two

main operating parameters have influenced the intensity of turbulence flow and the effective driving force.

The value of permeate flux at the end of each interval, as such 30 minutes interval is noted as,  $J_w^{30}$  and expressed as in Equation (5). At the end of the experiments, the membrane was dismantled and rinsed with distilled water to remove any deposition on the membrane surface. By doing so, the magnitude of  $R_f^{30}$  in Equation (5) was eliminated. The rinse took place with same operating conditions such as at transmembrane pressure, TMP of 0.2 bar and crossflow velocity, CFV of 3.0 L/min to obtain the water flux,  $v_w^{30}$ .

$$J_w^{30} = \frac{\Delta P}{\mu (R_m + R_{ad}^{30} + R_{pp}^{30} + R_f^{30})} \quad (5)$$

$$v_w^{30} = \frac{\Delta P}{\mu (R_m + R_{ad}^{30} + R_{pp}^{30})} \quad (6)$$

Similar procedure was conducted with few operating period of 60, 90 and 120 minutes. At particular operating parameters, pore plugging resistance and fouling resistance were evaluated. Therefore, the fouling layer resistance for reversible fouling at 60, 90 and 120 minutes can be determined.

### 3.0 RESULTS AND DISCUSSION

#### 3.1 Overall Spectrum of Flux Decline

*Pangasius sp.* wash water originally contains various types of macromolecules. Therefore, the first rinsed of surimi wash water were treated before fed to the tubular ultrafiltration membranes. Table 1 shows the characteristics of the *Pangasius sp.* surimi wash water and the permeate quality after filtration. Ultrafiltration of surimi wash water shows promising results in removing solutes, whereby almost 100% of removal of BOD, TSS and Turbidity. For proteins, this filter could remove about 64% of proteins. Thus, the filtration process has successfully produced the clarified wash water with satisfactory standard quality.

Fouling was mainly attributed by two main operating parameters namely TMP and CFV. TMP will affect the extent of convective flow mechanisms, while CFV indeed determine the Reynold numbers which indicate the degree of flow turbulence. Figure 2 shows a general pattern of flux decline for protein-based solution for 120 minutes of continuous separation process.

**Table 1** Characteristic of *Pangasius sp.* Surimi Washwater

PARAMETER	<i>Pangasius sp.</i> Surimi Wash Water			National Water Quality Standard	
	Raw	Pre-treated	Permeate	Class I	Class II (industrial standard)
BOD, mg/l	630.0	590.0	1.5	1.0	3.0
pH	6.72	6.00	6.02	6.5 – 8.5	6 – 9
Total Suspended Solid, mg/l	12.5	2.5	0.0	25	50
Turbidity, NTU	1050	935	2	5	50
Protein content, g/l	3.2	2.8	1.1	-	-

The permeate flux declined rapidly for the first 10 minutes after the ultrafiltration of surimi wash started, and further declination was then observed for the next phases of filtration. In

general, flux decline is caused by several phenomenon, in, on and near the membrane. The extent of flux reduction is believed mainly due to the increment of solutes deposition and bacterial growth throughout the filtration process. The protein in surimi washwater is organic and has wide range of sizes. Thus, protein acted as foulant deposited up to formation of cake layer. In this case, fouling behaviour in surimi ultrafiltration could be portrayed through four phases. The overall spectrum of flux decline therefore could be divided into four major phases as shown in Table 2.

**Figure 2** Overall spectrum of fouling occurrence during ultrafiltration of surimi wash water for 120 minutes

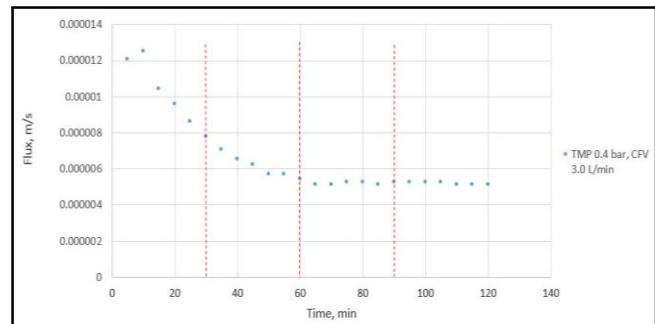

**Table 2** Description of four major phases in overall spectrum

PHASE	DURATION	DESCRIPTION
Phase 1	First few seconds	A quasi-steady-state-concentration polarization layer.
Phase 2	1 – 10 minutes	Solute adsorption which known as adsorption resistance
Phase 3	Long term	Gel layer deposition which known as Pore plugging resistance
Phase 4	Long term	Cake formation which known as and fouling resistance

The drastic reduction of flux (more than half of initial values) therefore was contributed by phase 1, phase 2 and phase 3 which could be termed as 'reversible fouling'. In this region, the adsorption of small molecules and small impurities onto PVDF tubular membrane surface were gradually build-up within few minutes of filtration. Due to the various molecular weights of impurities (solutes) with different transport capabilities, the concentration polarization (within few seconds of filtration) would have a significant strong effect on solute retention. This type of fouling is reversible in nature and the membrane permeability could be recovered with proper arrangement of membrane cleaning procedure. A physical membrane cleaning approach such as backwashing, back flushing or ultrasonic approaches are suitable for reversible fouling. It has shown that flux can possibly be recovered by few times and few minute operation of back flushing (Figure 3).

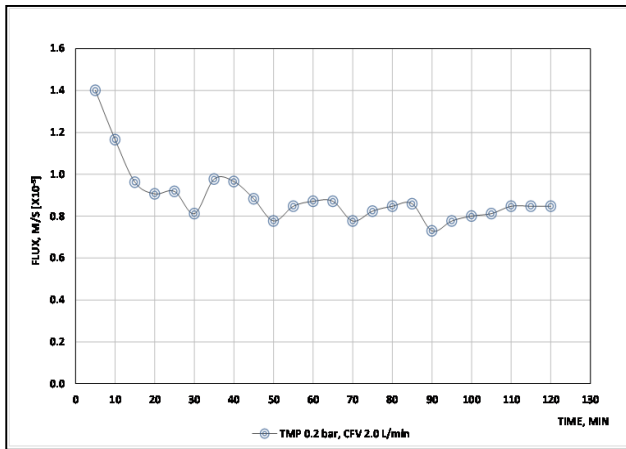

Figure 3 Improved flux via backflushing

**3.2 Analysis of the Effect of TMP and CFV on the Solute Resistance using Resistance-in-Series Model**

The solute resistance throughout fouling spectrum has been investigated for the variation of two selected operating parameters i.e. trans-membrane pressure (TMP) and cross flow velocity (CFV) under steady state conditions. Four different types of resistances throughout the filtration process of surimi washwater were all determined based on operating conditions. The resistances are membrane resistances,  $R_m$ , adsorption resistance,  $R_{ad}$ , pore plugging resistance,  $R_{pp}$  and fouling resistance,  $R_f$ . The values of these resistances for each operating condition were portrayed in Table 3.

Initially, the built-in membrane made a resistance of  $1.284 \text{ m}^{-1}$  which is known as an average membrane resistance. For the purpose of membrane quantification approach, value of the membrane resistance for all membrane samples was taken as an average membrane resistance. In general, the highest resistance is pore plugging resistance followed by adsorption resistance, fouling resistance and lastly membrane resistance. The relation of resistances values can be portrayed as as follows;  $R_{pp} > R_{ad} > R_f > R_m$ . Form our observation during ultrafiltration process of surimi washwater, pore plugging resistance is always higher than adsorption and fouling resistance. Fouling resistance can also be named as cake resistance in which cake layer is forming on the membrane surface indicating the needs of cleaning action. Concentration of polarization however embarks pore plugging of solute at membrane pores. This fouling phenomenon was quite similar with work done by Juang *et al.* [8]. They have used membrane to filter fermentation broth by which bacterial cake resistance ( $R_c$ ) was found to be consistently lower than adsorption resistance ( $R_{ad}$ ) and solute concentration polarization resistance ( $R_p$ ), meanwhile  $R_c$  is high from the beginning of the experiment.

The build-up of foulants in surimi with time could be presented arbitrary as in Figure 4. The built up resistances will in the long run, accumulated as total resistance in which significant in prediction of flux.

Table 3 Values of various resistances for different operating parameters

TMP, bar	CFV, L/min	Time,min	$R_m / R_m$	$R_{ad} / R_m$	$R_{pp} / R_m$	$R_f / R_m$	$R_{total} / R_m$
0.2	2	0	1	0	0	0	1
		30	1	1.984	0.284	0.997	4.266
		60	1	1.988	1.956	1.566	6.510
		90	1	1.984	2.137	1.697	6.818
		120	1	1.982	2.183	1.702	6.868
	3	0	1	0	0	0	1
		30	1	2.238	0.406	0.763	4.407
		60	1	2.260	1.932	0.788	5.981
		90	1	2.227	2.469	0.988	6.684
	4	0	1	0	0	0	1
		30	1	2.291	0.680	0.833	4.805
		60	1	2.260	2.407	1.007	6.673
90		1	2.230	2.174	1.364	6.769	
0.4	2	0	1	0	0	0	1
		30	1	2.033	0.369	0.694	4.095
		60	1	2.342	2.171	0.970	6.483
		90	1	2.328	2.470	1.026	6.824
	3	0	1	0	0	0	1
		30	1	2.194	0.327	0.308	3.829
		60	1	2.028	2.143	1.089	6.260
		90	1	1.974	2.263	1.941	7.178
	4	0	1	0	0	0	1
		30	1	2.425	0.663	0.438	4.526
		60	1	2.273	1.136	1.071	5.481
		90	1	2.074	3.101	1.208	7.382
120	1	2.202	3.094	1.395	7.692		

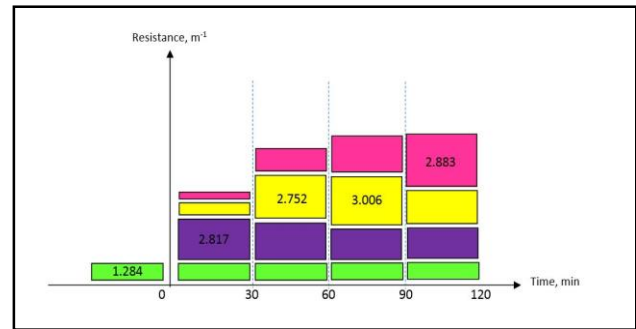

Figure 4 Foulants built up portrayed as values of resistances for particular operating condition of TMP 0.4 bar and CFV 3.0 L/min

The growth of the adsorption resistance with time is determined and the results are presented in Figure 4. It is observed that adsorption resistance increases with time initially and it remains nearly constant after 60 minutes. The values of  $R_{ad}$  is about 160% of the membrane hydraulic resistance,  $R_m$ . For any interval of time, flux declination is contributed by the combination of the evaluated resistances. However, a specific resistance was mainly responsible for fouling occurrence in the particular time interval. For the first interval of 30 minutes, flux decline was greatly caused by adsorption. Adsorption resistance is the highest resistance during this particular period. Pore plugging and fouling resistance is less than 20% of the sum of resistance in the first 30 minutes of filtration process.

After 30 minutes of filtration, flux decline was mainly contributed by pore plugging resistance for an hour. Pore plugging is a condition of gel layer deposition onto the membrane surface. Throughout the ultrafiltration of surimi washwater, pore plugging resistance is the highest resistance quantified.

Backflushing and backwashing is promising technique in overcoming gel layer deposition in which will reduce the pore plugging resistance. Cake formation leads to fouling which evaluated as fouling resistance. The time interval of 120 minutes showed the highest resistance is fouling resistance, in which it increased through time as fouling layer develop during ultrafiltration process.

The growth of adsorption resistance was further analysed and portrayed in a graph as in Figure 5. From the curve, it is clearly understood that adsorption resistance increases with time and it remains constant after several minutes of filtration. The magnitude of adsorption resistance can be presented as in Equation (7);

$$R_a = 2.548 - 2.548 [\exp(-1.08536t)] \tag{7}$$

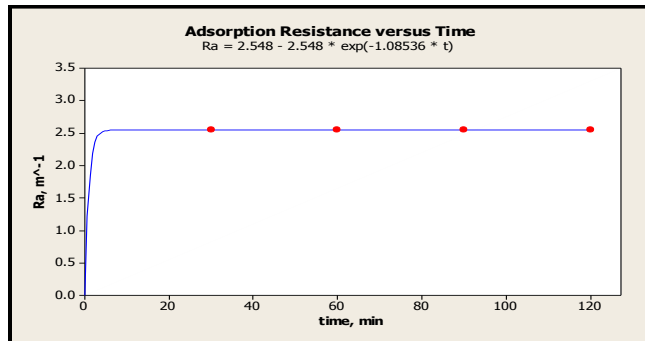

Figure 5 Fitted graph of adsorption resistance versus time in a function of logistic growth at TMP 0.4 bar and CFV 3.0 L/min

The profile of  $R_{pp}$  at various CFV for TMP 0.2 bar is shown in Figure 6. The pattern of  $R_{pp}$  is fitted to a polynomial curve as the  $R_{pp}$  is continuously increasing over time. Compared to  $R_{ad}$ ,  $R_{pp}$ , increases rapidly initially and gradually in the next minutes while  $R_{ad}$  it increases rapidly in the first few minutes yet, it remains constant after approximately 30 minutes of operation. At the end of 120 minutes, it is doubled of membrane hydraulic resistance. At lower crossflow velocity,  $R_{pp}$  steadily increase through time. This can be the effect of more solutes accumulated towards membrane surface and form gel layer. On the other hand, during highest CFV of 4.0 L/min  $R_{pp}$  increases for the first 60 minutes and gradually decrease in the next 60 minutes. It is believed that the turbulence flow of the surimi washwater partially scours the deposited foulants on the membrane surface. This condition also leads to less transmission of solutes through the membrane which resulting in lower values of pore plugging.

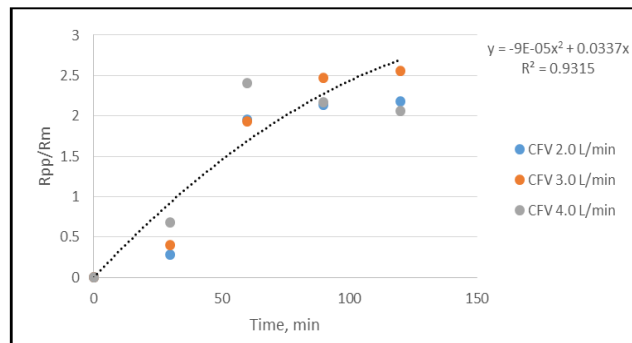

Figure 6 Pore plugging resistance values for varied CFV at TMP 0.2 bar

Effects of transmembrane pressure can clear be seen after 30 minutes of filtration process as in Figure 7. At the 30<sup>th</sup> minute,  $R_{pp}$  quantified for TMP 0.2 bar and 0.4 only have a slight different of 0.044/m. Further filtration shows a significant different of resistance values as  $R_{pp}$  at lower transmembrane pressure is higher than  $R_{pp}$  at high transmembrane pressure. The different of total  $R_{pp}$  for overall filtration process of 120 minutes is 11.3%. According to P.Rai *et al.* [9], at higher Reynolds number, turbulence created at the membrane solution interface, favors upward lift of the solutes leading to less transmission of them through the membrane, resulting in lower values of pore plugging resistance. In this study, the same event happened due to combination of higher CFV and TMP.

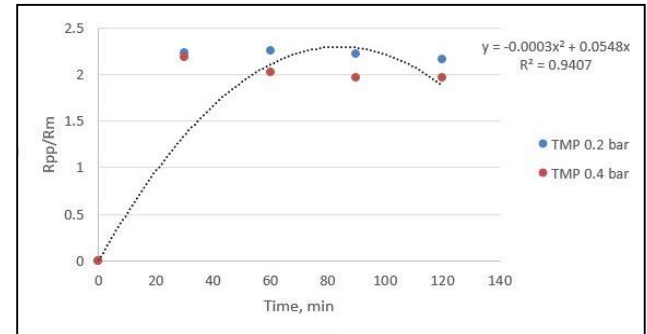

Figure 7 Pore plugging resistance values for varied TMP at CFV 3.0 L/min

The profile of membrane fouling resistance was obtained and portrayed as in Figure 8. Based on the figure it is found that fouling grows steadily over period of time. As time increases, the amount of solutes being transported towards membrane surface increases. Thus, the amount of resistance increases due to deposition of protein on membrane surface and into the pores.

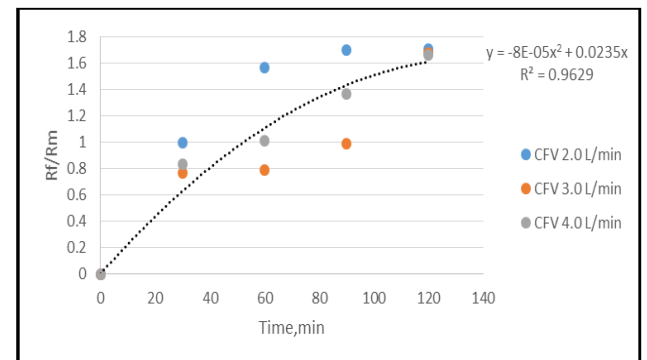
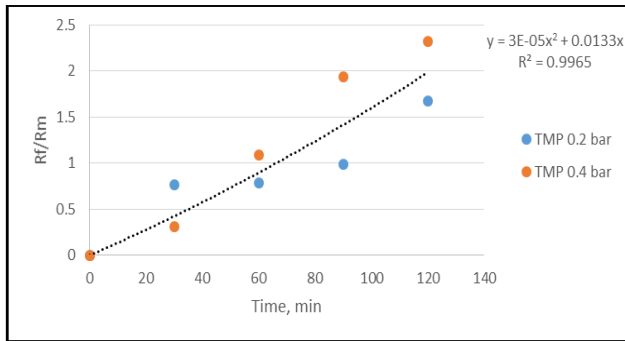

Figure 8 Fouling resistance values for varied CFV at TMP 0.2 bar

Effect of TMP towards fouling resistance of specific CFV of 3.0 L/min was portrayed in Figure 9. In contrast to  $R_{pp}$ ,  $R_f$  at lower transmembrane pressure is lower than  $R_c$  at high transmembrane pressure. Higher pressure exerted to membrane surface creates stronger deposition effects. Different of fouling resistance value is highest at 90 minutes time interval which is 96.5% increment as pressure increased. Different trendlines observed for CFV and TMP. TMP as reported by A.F Derradji *et al.* [10] injected air as turbulence promoter resulted in increasing of flux. In contrast, increase of CFV not proportionally increase flux. High CFV



promoted fouling occurrence in which solutes accumulate on the membrane surface after clogging membrane pores.



**Figure 9** Fouling resistance values for varied TMP at CFV 3.0 L/min

Based on the computed correlations of resistance of interest, the total resistances for various crossflow velocity were plotted in a graph of Figure 10. The figure reveal an interesting trend in which the highest CFV shows highest total resistance yet for particular interval of 120 minutes, highest CFV showed the lowest resistance. Higher CFV creates higher turbulence flow. To certain extend, high turbulence will limit the growth of resistance layer. It is because, turbulence at membrane-solute interface increase the flow vortex significantly produce an upward lift of the solutes. This resulting to a scour of deposited foulant or thinning of gel layer existed.

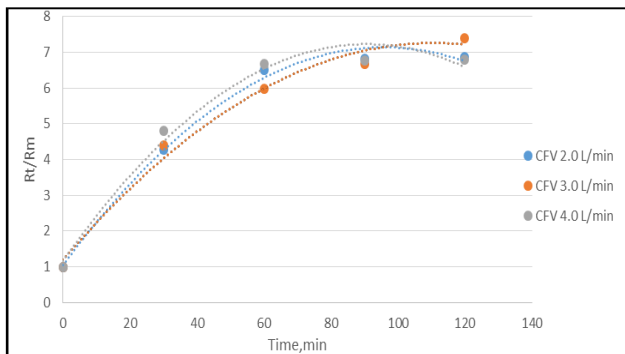

**Figure 10** Total resistance values for varied CFV at TMP 0.2 bar

At the same CFV of 3.0 L/min, R<sub>t</sub> values for varies TMP of 0.2 bar and 0.4 bar were plotted in a graph of Figure 11. Based on the graph, the two operating parameters show two distinguish patterns. For TMP 0.2 bar, the total resistance at 30 minutes interval is 15.1% higher than the total resistance for TMP 0.4 bar. However, the at 60 minutes interval, total resistance of both pressure are almost similar which differ for only 4.7%.

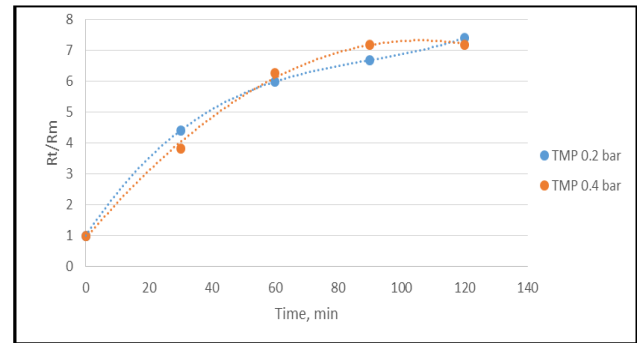

**Figure 11** Total resistance values for varied TMP at CFV 3.0 L/min

Total resistance of filtration process at TMP 0.2 bar and 0.4 bar showed different pattern of each. Trade-off point existed just before the 60 minutes interval make the 60 and 120 minute interval pattern in contrast with the first time interval of 30 minutes. However, the second trade-off point also occurs right before the interval of 120 minutes in which the forward filtration follows the trend of the first 30 minutes interval. Highest different of R<sub>t</sub> values was obtained at 90 minutes interval which is 0.5 magnitude in different.

#### 4.0 CONCLUSION

A resistance in series model approach was implemented in a series of experiments. It is used to quantify resistances that contribute to flux decline during ultrafiltration of surimi washwater. Flux decline were contributed by the adsorption, pore plugging and reversible fouling resistance. Adsorption of foulant to the membrane's surface resulting a monolayers formation and eventually compaction of those monolayers contribute to reversible fouling. The best operating conditions in reducing resistance which contribute to fouling occurrence based on the experiment was at CFV 3.0 L/min and TMP 0.2 bar. At the lowest CFV and TMP, the total resistance magnitude insignificantly differs. On the other hand, a slight difference in total resistance was found at operating condition at highest CFV and highest TMP. A Significant different only has been portrayed at CFV 3.0L/min. With respect to total resistance, at TMP 0.2 bar the total resistance is lower than at TMP 0.4 bar for this particular CFV. On top of all, the contribution of resistance was mainly due to adsorption resistance followed by pore plugging resistance, fouling resistance and lastly membrane resistance.

## Nomenclature

$J_w$	permeate flux of the juice ( $\text{m}^3/\text{m}^2 \text{ s}$ )
$\Delta P$	transmembrane pressure (Pa)
$\mu$	viscosity (Pa.s)
$R_m$	membrane hydraulic resistance ( $\text{m}^{-1}$ )
$R_{ad}$	adsorption resistance ( $\text{m}^{-1}$ )
$R_{pp}$	pore plugging resistance ( $\text{m}^{-1}$ )
$R_f$	fouling resistance ( $\text{m}^{-1}$ )
$L_p$	membrane permeability ( $\text{m}/\text{Pa.s}$ )
$V_w$	permeate flux of distilled water ( $\text{m}^3/\text{m}^2.\text{s}$ )
$J_w^t$	permeate flux of the fruit juice after t min ( $\text{m}^3/\text{m}^2.\text{s}$ )
$R_{ad}^t$	adsorption resistance after t min ( $\text{m}^3/\text{m}^2.\text{s}$ )
$R_{pp}^t$	adsorption resistance after t min ( $\text{m}^3/\text{m}^2.\text{s}$ )
$R_f^t$	adsorption resistance after t min ( $\text{m}^3/\text{m}^2.\text{s}$ )
$v_w^{30}$	permeate flux of distilled water, using the membrane after t min ( $\text{m}^3/\text{m}^2.\text{s}$ )

## Acknowledgement

A million thanks to Ministry of Higher Education for FRGS of VOT59273 in providing the fund and also sincere gratitude for hard work and cooperation from University Malaysia Terengganu staffs and students involved.

## References

- [1] Toshiaki, O., S. Toru, and K. Chiaki. 1993. New Developments in Surimi Technology *Journal of Food Science and Technology* 4: 157–163.
- [2] Raja, G. 2003. *Protein Bioseparation using Ultrafiltration–Theory, Applications and New Developments*. Singapore: World Scientific Publishing.
- [3] Jennifer, L., W. Barbara, L. J. Angel, and J. M. Todd. 2011. Recovery of High Value Protein from a Corn Ethanol Process by Ultrafiltration and an Exploration of the Associated Membrane Fouling. *Journal of Membrane Science*. 366: 405–412.
- [4] Sarigalu, M., G. Insel, and D. Orhon. 2012. Dynamic In-Series Resistance Modelling and Analysis of a Submerge Membrane Bioreactor Using Novel Filtration Mode. *Desalination*. 285: 285–294.
- [5] Yanlei, S. 2008. Modification of Polyethersulfone Ultrafiltration Membranes with Phosphorylcholine Copolymer can be Remarkably Improve The Antifouling and Permeation Properties. *Journal of Membrane Science*. 322: 171–177.
- [6] Lianfa, S. 1998. Flux Decline in Crossflow Microfiltration and Ultrafiltration: Mechanism and Modeling of Membrane Fouling. *Journal of Membrane Science*. 139: 183–200.
- [7] Lihan, H., and M. T. Morrissey. 1998. Fouling of Membranes During Microfiltration of Surimi Wash Waster: Roles of Pore Blocking and Surface Cake Formation. *Journal of Membrane Science*. 144: 113–123.
- [8] Ruey-Shin, J., Chen, H.L., and Chen, Y.S. 2008. Resistance-in-series Analysis in Cross-Flow Ultrafiltration of Fermentation Broths of *Bacillus Subtilis* Culture. *Journal of Membrane Science*. 323: 193–200.
- [9] Rai, P., C. Rai, G.C. Majumdar, S. DasGupta, and S. De. 2006. Resistance in Series Model for Ultrafiltration of Mosambi (Citrus Sinensis (L.) Osbeck) Juice in a Stirred Continuous Mode. *Journal of Membrane Science*. 283: 116–122.
- [10] Derradji, A. F., S. Taha, and G. Dorange. 2005. Application of the Resistance in Series Model in Ultrafiltration. *Desalination*. 184: 374.