

A REVIEW ON ENHANCING HUMAN-MACHINE-ENVIRONMENT INTERFACE FOR POSTURA MOTERGO™

Wan Muhammad Syahmi Wan Fauzi*, Abdul Rahman Omar, Roseleena Jaafar, Muhammad Izzat Nor Ma'arof, Helmi Rashid

Motorcycle Engineering Technology Lab (METAL), Faculty of Mechanical Engineering, Universiti Teknologi MARA, Shah Alam, Selangor, Malaysia

Article history

Received
31 January 2015
Received in revised form
30 April 2015
Accepted
31 May 2015

*Corresponding author
syahmie_putraz@yahoo.com

Graphical abstract



Abstract

In this era of critical traffic congestion, motorcycles have become one of the popular go-to vehicles. Recently, there are several motorcycle simulators that were developed by several group researchers around the world due to the statistics of motorcycle road accidents globally alarming. They are developed for 2 different purposes which are as testing on prototype models prior to mass production and also as conducting a study on human skills and behaviour in specific motorcycling conditions. The aim of this study was to review several issues detected with respect to the currently available motorcycle simulators. In addition, a special attention was given to a motorcycle test rig named the Postura Motergo™. The Postura Motergo™ is a new revolutionary motorcycle test rig which was developed based on Riding Posture Classification (RIPOC) system. However, it is noticeable that the current design of Postura Motergo™ could be improved to further elevate users' experience. Other than adding to better fidelity of the motorcycle test rig, further improvements with respect to design, functionality and users' experience would ensure the design longevity and overall cost effectiveness provided by the particular motorcycle test rig. Thus, enables the particular motorcycle test rig to contribute to various motorcycle ergonomics researches in the near future. Such matter would then be hope to ultimately aid in reducing the global motorcycle road accident statistics.

Keywords: Motorcycle, test rig, Postura Motergo™, ergonomics, RIPOC system

© 2015 Penerbit UTM Press. All rights reserved

1.0 INTRODUCTION

1.1 Motorcycle Simulators: General Review

Motorcyclists have been categorized as vulnerable road users with a higher risk [1]. A motorcycle simulator was invented to give real experience while handling motorcycle in a controlled laboratory environment with the capability to compute the dynamic behaviour of the motorcyclist [2]. It is the safest way of handling the motorcycle due to the absence of real hazard conditions from the real road. However, a number of matters were caught into attention upon

reviewing currently available motorcycles. The aim of this study was to review several issues detected with respect to the currently available motorcycle simulators.

Firstly, generally, the current motorcycle simulators are mostly exclusive to only one riding posture type. Due to the use of real motorcycle for the simulator, the simulator could only replicate one type of riding posture based on the motorcycle design limitations. This are most probably because these simulators use real motorcycle for the simulator. Ma'arof and Ahmad (2012) noted that there are four types of riding postures that could be practiced [3]. Thus, it is strongly

suggested that it would be greatly advantageous with respect to research convenience to have a motorcycle simulator that could replicate all these riding postures. More in-depth study could be performed on motorcycle ergonomics, without the need to continuously replace the simulator with various motorcycle types.

Secondly, largely, the currently available motorcycle simulators could not truly replicate the real world motorcycling experience. It was already documented by Ma'arof et al., (2012) and Stedmon (2010) that the external motorcycling elements or the environment plays a major part in affecting motorcycling ergonomics in real world riding conditions [3, 4]. Windblast, shocks and jerks, weather and climate are among the "HMEI" elements noted by Ma'arof et al., (2012) that could significantly affects the human operator. There is the need to have a motorcycle simulator that could truly replicate the real world motorcycling experience.

Finally, commonly, all of the established motorcycle simulators are limited to training and gaming i.e. not truly dedicated for research purposes. The bells and whistles of training/gaming motorcycle simulator are considerably contrasting to the ones for research purposes. Henceforth, it would be best if a specific –

research based motorcycle simulator – is being established.

Conclusively, further improvements could be made for the currently available motorcycle simulators. Even so, the closest specimen of a motorcycle simulator that could overcome 2 out the 3 highlighted issues were established by the researcher from the Motorcycle Engineering Test Lab (METAL) of the Faculty of Mechanical Engineering, Universiti Teknologi MARA, Malaysia in April 2014. The motorcycle test rig is named the Postura Motergo™.

1.2 Postura Motergo™

The Postura Motergo™ is a revolutionary motorcycle test rig established by a group of researchers from the Motorcycle Engineering Test Lab (METAL™) of Faculty of Mechanical Engineering, Universiti Teknologi MARA (UiTM) Malaysia (see Figure 1). It is a custom-made motorcycle test rig that utilized the Riding Posture Classification (RIPOC) system [5-7] as functionality reference i.e. the motorcycle test rig could cater for adjustability features to replicate the 4 types of riding postures as noted by the system. Nevertheless, the Postura Motergo™ requires a number of designs improvements.



Figure 1 Postura Motergo™ from METAL, UiTM [5, 6]

Firstly, the Postura Motergo™ could be further improved with respect to the models representation aspects. This issue is with respect with the capability of the Postura Motergo™ in representing various types of motorcycle cockpit designs in order to maintain design validity and fidelity. The structural body (the area between the handlebar and the seat) of the Postura Motergo™ was designed as a

rigid feature. Henceforth, no adjustment could be made on the structural body to represent different structural body design parameters. In order to cater for various motorcycle cockpit designs parameters and simultaneously replicating better different types of motorcycle models, design upgrade is warranted.

Secondly, it is foreseen that the current adjustability features of Postura Motergo™ from the standpoint of

design functionality and ease of usage require enhancement. Currently, both the clip-ons handlebars and foot-pegs are not synchronized and independently adjusted to acquire the desired design settings. Hence, this research will improve the adjustable features, thus, providing better system stability for the Postura Motergo™.

Finally, the Postura Motergo™ is yet to have a full capacity in replicating real world motorcycling

experience. The experience of the users with respect to the current Human Motorcycle-Environment Interface (HMEI) [5] suggestively requires additional upgrading due to several issues. For example, the Postura Motergo™ only has two degree of freedom (DOF) that could be noted as very restricted in comparison to existing motorcycle simulators. Table 1 gives summary on the DOF integrated in past and current motorcycle simulators.

Table 1 Summary on the DOF integrated in past and current motorcycle simulators

| Country of origin | Name/Brand | Number of Degree of Freedom (DOF) | List of Degree of Freedom (DOF) |
|-------------------|--------------------------------------|-----------------------------------|---|
| | Honda (model 1988) [8, 9] | 5 | lateral, roll, yaw, pitch and steering |
| Japan | Honda (model 1999) [8, 10] | 3 | roll, pitch and steering |
| | Tsukasa Kishida motorcycle simulator | 3 | roll, pitch and steer axis |
| Italy | UNIPD [11, 8] | 5 | lateral, yaw, roll, pitch and steer motions |

In definition, the 'roll' DOF is to simulate short cornering activity, whilst, 'pitch' is for creating acceleration and braking illusion, while finally, 'yaw' is to replicate accident sensation/situation induced by rear wheel skidding [8]. In short, by integrating greater environmental and also a better mechanical mechanism, the degree of freedom for the greater replication of real world motorcycling environment could be attained. Therefore, greater users experience could be achieved, thus, promoting better validity and fidelity of the Postura Motergo™.

In the year 1988, Honda had integrated its motorcycle simulator with 5 degree of freedom (DOF) that was assembled on a cradle system. The 5 DOF selected were lateral, roll, yaw, pitch and steering which were all controlled by 7 actuators. Even so, in 1990, the second motorcycle simulator built by Honda only consists of 3 DOF that are roll, pitch and steering. Figure 2 shows the 5 Degree of Freedom integrated into the UNIPD motorcycle simulator [8].

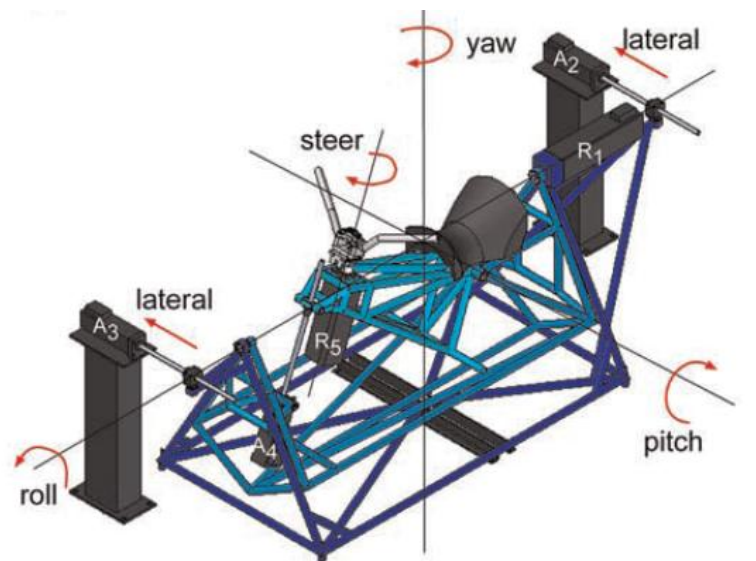

Figure 2 Five degrees of Freedom in UNIPD motorcycle simulator [8]

Conclusively, there are rooms of improvement for the Postura Motergo™. Figure 3 shows the theoretical framework of this study that will be conducted in

improving the Postura Motergo™ in an effort to provide motorcycle researchers a better facility.

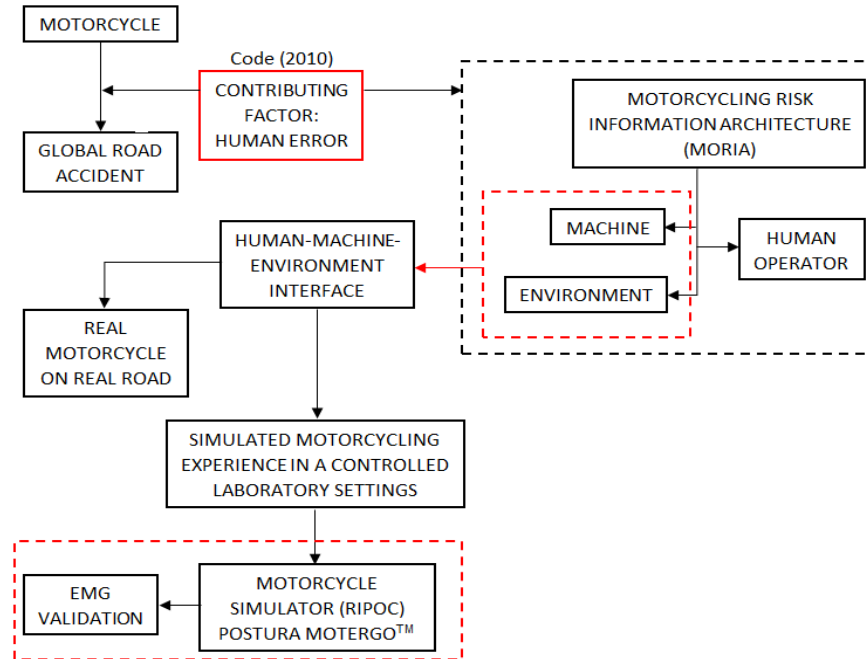

Figure 3 Theoretical framework in improving the Postura MotergoTM

By improving the current design of the motorcycle test rig, fidelity and validity values of the particular motorcycle test rig could be further enhanced. Furthermore, such improvements could further stretch the design limitations of the Postura Motergo™, thus, enables the particular motorcycle test rig to contribute to various motorcycle ergonomics researches in the near future. Henceforth, ensuring design longevity and overall cost effectiveness.

2.0 CONCLUSION

Conclusively, indeed the Postura Motergo™ is a revolutionary motorcycle test rig that is truly dedicated for motorcycle ergonomics research purposes. However, there are still vast rooms for improvement in concerning this particular motorcycle test rig. By further enhancing the test rig design, functional capabilities and overall users' experience in interfacing with the test rig; better fidelity could be acquired for the motorcycle test rig. The newly enhanced Postura Motergo™ is anticipated to further seeds and facilitates for more in-depth explorations and researches with respect to motorcycling in a controlled laboratory setting, thus, avoiding any real road hazards on the human operator. Such matter would then be hope to ultimately aid in reducing the global motorcycle road accident statistics.

Acknowledgement

The author would like to acknowledge the Ministry of Education (MOE) Malaysia for providing the research fund for this study through the Fundamental Research Grant Scheme (FRGS/1/2014/TK01/UITM/02/3). The authors would also like to thank all members of the Motorcycle Engineering Test Lab (METAL), the staff of the Faculty of Mechanical Engineering and the Institute of Graduate Studies in Universiti Teknologi MARA and the Human Factors and Ergonomics Society Malaysia who have, directly or indirectly, contributed to this research.

References

- [1] Transport, M. O. 2012. Crash Statistics For The Year Ended 31 December 2011. Ed. 2012.
- [2] Nehaoua, L., Arioui, H. and Mammar, S. 2011. Review On Single Track Vehicle And Motorcycle Simulators. *The 19th Mediterranean Conference on Control and Automation, Aquis Corfu Holiday Palace, Corfu, Greece.*
- [3] Ma'arof, M. I. N., Ahmad, I. N., Abdullah, N. R. and Karim, S. A. 2012. Motorcycling Riding Issues: Understanding the Phenomenon and Development of Ergonomics Intervention in Improving Perceived Comfort for Prolonged Riding. in *iDECON*.
- [4] Stedmon, A.W. 2010. HMI: Human Motorcycle Interaction. *Centre for Motorcycle Ergonomics and Rider Human Factors, Dept of Mechanical, Materials, Manufacturing Engineering (M3.) University of Nottingham.* 1-18.
- [5] Fauzi, W. M. S. b. W. 2014. Thesis : *Integrating Human-Machine-Environment Interface (HMEI) Elements into an*

- Ergonomic Motorcycle Test Rig to Replicate Near-To-Real Riding Scenario," Bachelor of Engineering (Hons) (Mechanical), Mechanical Engineering, Universiti Teknologi Mara (UiTM).*
- [6] Hafizudin, M. 2014. Thesis : *An Ergonomic Motorcycle Test Rig based on Motorcyclist Riding Posture Classification (RIPOC) System," Bachelor of Engineering (Hons) (Mechanical), Mechanical Engineering, Universiti Teknologi Mara (UiTM).*
- [7] Rashid, H., Ma'arof, M. I. N., Omar, A. R., Abdullah, S. C. and Jaafar, R. 2014. Evolution of a New Adjustable Motorcycle Test Rig for Measuring Motorcyclist Fatigue during Prolonged Riding. *Advances in Human Aspects of Transportation: Part II*. 8: 3.