

# ENVIRONMENTAL FRIENDLY BIO-PESTICIDE ROTENONE EXTRACTED FROM *Derris* sp.: A REVIEW ON THE EXTRACTION METHOD, TOXICITY AND FIELD EFFECTIVENESS

## Article history

Received  
24 October 2015  
Received in revised form  
16 February 2016  
Accepted  
15 July 2016

Saiful Irwan Zubairi<sup>a\*</sup>, Zetty Shafiqah Othman<sup>a</sup>, Mohamad Roji Sarmidi<sup>b</sup>, Ramlan Abdul Aziz<sup>b</sup>

\*Corresponding author  
saiful-z@ukm.edu.my

<sup>a</sup>School of Chemical Sciences and Food Technology, Faculty of Science and Technology, Universiti Kebangsaan Malaysia, 43600 UKM Bangi, Malaysia

<sup>b</sup>Institute of Bioproduct Development, Universiti Teknologi Malaysia, 81310 UTM Johor Bahru, Johor, Malaysia

## Graphical abstract

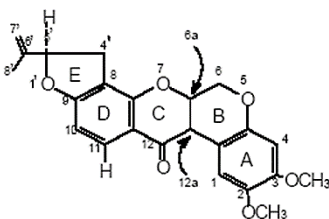

## Abstract

Bio-pesticides are natural occurring substances that control pest and derived either from plants or microorganism. It play a vital role in coping with adverse effect arise due to massive used of synthetic pesticides and development of insecticide resistance of some insect groups in crop productions. Thus, *Derris* species from Leguminosae (Fabaceae) family is a climbing plant of Southeast Asia that was well known for its environmental friendly bioactive compound is used as one of the effective insecticides. Rotenone was one of the bioactive constituents extracted from *Derris* plant that was used as agricultural pest control due to its strong paralysis action (knock-down effect) on cold blooded animals. Moreover, it has a lethal mechanism in inhibiting respiratory enzyme of insects and easily degrades which makes it environmental friendly. Extraction of rotenone commonly uses organic solvents as extractant either in non-conventional extraction methods or conventional method. Application of green solvents, ionic liquids as extractant is new approach for rotenone extraction. Indeed environmental friendly bio-pesticides have not been studied thoroughly and several approach and further study are required to produce high quality and environmental friendly bio-pesticides. In addition, biological assay such as "Brine Shrimp (*Artemia salina*) Lethality" study is also vital in order to determine a preliminary safe exposure limit of extracted rotenone prior to be used as pesticides. For that reason, a review of the environmental friendly bio-pesticide rotenone extracted from *Derris* sp. is presented herewith. This article reviews the up scaling extraction methods, toxicity and its effectiveness against several moth species such as *Spodoptera litura* and *Plutella xylostella*.

**Keywords:** *Derris* sp., Bio-pesticide, Rotenone, Extraction, Toxicology, Biological assay

## Abstrak

Bio-pestisid merupakan bahan semulajadi yang wujud bagi mengawal makhluk perosak dan dihasilkan samada daripada tumbuhan atau mikroorganisma. Ia memainkan peranan yang penting di dalam membantu kesan sampingan yang semakin meningkat disebabkan oleh penggunaan pestisid yang berleluasa dan kerintangan insektisid oleh sekumpulan serangga dalam penghasilan hasil pertanian. Oleh yang demikian, spesies *Derris* daripada keluarga Leguminosae (Fabacea) adalah tumbuhan memanjat Asia Tenggara yang terkenal dengan bahan bioaktif bersifat mesra alam digunakan sebagai salah satu daripada insektisid yang efektif. Rotenon adalah salah satu sebatian bioaktif yang diekstrak daripada tumbuhan *Derris* yang digunakan dalam mengawal serangga perosak pertanian akibat tindakan kelumpuhan yang kuat (kesan pengsan) ke atas haiwan berdarah sejuk. Di samping itu, ia juga mempunyai mekanisme berbahaya dalam menghalang enzim pernafasan serangga dan mudah terdegradasi di mana menjadikan ia sebagai bahan yang mesra alam. Pengekstrakan rotenon biasanya menggunakan pelarut organik sebagai bahan pengekstrak sama ada di dalam kaedah pengekstrakan bukan konvensional ataupun kaedah konvensional. Penggunaan pelarut hijau, cecair berionik sebagai bahan pengekstrak merupakan pendekatan terbaru dalam pengekstrakan rotenon. Walaubagaimanapun, bio-pestisid mesra alam masih belum dikaji sepenuhnya dan beberapa pendekatan serta kajian lanjut diperlukan bagi menghasilkan racun serangga yang berkualiti tinggi dan benar-benar mesra alam. Di samping itu, asai biologi sebagai contoh "Brine Shrimp" (*Artemia salina*) adalah penting untuk menentukan had pendedahan awal hasil ekstrak rotenone yang selamat sebelum ianya boleh digunakan sebagai racun perosak. Oleh yang demikian, kajian berterusan terhadap racun perosak mesra alam rotenone yang diekstrak daripada spesies *Derris* diperjelaskan di dalam artikel ini. Artikel ini menjelaskan kaedah penskalaan proses pengekstrakan, ketoksikannya dan keberkesanan rotenon terhadap beberapa spesies ulat seperti *Spodoptera litura* dan *Plutella xylostella*.

**Kata kunci:** *Derris elliptica*, bio-pestisid, rotenon, pengekstrakan, toksikologi, asai biologi

© 2016 Penerbit UTM Press. All rights reserved

## 1.0 INTRODUCTION

One of the important issues facing approximately 6.48 billion world populations [1] is food security. The over population in developing countries and low food production exacerbated the situation. Low food production productivity is due to many factors. One of the factors is due to pest and plant diseases. Crop protections today rely heavily on synthetic pesticides [2] Their uninterrupted and massive use has led to several side effects such as pesticides resistance in pests resulting in the use of double and triple application rates [3, 4], elimination of naturally occurring biocontrol agents, insect resurgence, adverse effects on non-target organisms and environment contaminations with the potential effect on the entire food chain [5, 6]. It was reported by the World Resources Institutes that more than 500 insects and mite species are immune to one or more insecticides [7] and the World Health Organization (WHO) estimates that 200,000 people are killed worldwide every year as a direct result of pesticide poisoning.

The widespread use of pesticides for improving agricultural productivity has raised public concern about the possible presence of residues in food such

as fruits and vegetables and the hazards associated with excessive use of synthetic pesticides. This revived the interest in the use of environmental-friendly crop protection products or well known as phytochemical pesticides. Phytochemical pesticides or biopesticides offer a more sustainable solution to pest control than synthetic alternatives as it were environmentally benign, biodegradable [8], maintain biological diversity of predators [9] and safer to higher animals including human beings. Moreover, biopesticides do not feature residue problems which are matter of significant concern for consumer.

A vast number of plant species produce phytochemicals that are not directly beneficial for the growth and development of the plants. These secondary compounds are regarded as a part of the plants defense against plant-feeding insects and other herbivores [10]. The pesticide properties of many plants have been known for a long time and natural pesticides based on plant extracts such as rotenone, nicotine and pyrethrum have been commonly used in pest control during the earlier half of this century. Apart from localized use of traditional plant materials and isolation of a number of phytochemicals with insecticidal properties [10],

only two botanical insecticides, pyrethrum and rotenone are in widespread use. Rotenone and its derivatives are well known for their insecticidal properties. They occurred naturally as constituents of the roots, stems and leaves of many leguminous (Fabaceae) species of the genera *Derris*, *Lonchocarpus*, and *Tephrosia*. *Derris* is a small shrub originating in tropical rainforest of Malaysia. There were three *Derris* species found in Malaysia which are *Derris elliptica*, *Derris malaccensis*, and *Derris uliginosa* [11]. This woody creeper and climber plant grows in lowland areas and does not thrive at high altitude. It needs at least 75% soil moisture content with surrounding temperature approximately 25 to 30 °C to produce high yield of rotenone. In general, plants with pesticidal properties can be used in three ways. Initially, from the whole plant parts, in powder form or as crude extracts in water or other solvents. Secondly, as purified extracts, such as rotenone and finally as a chemical template which could be produced industrially such as pyrethrins that were chemically synthesized.

### 1.1 Metabolic Pathway of the Phytochemicals Insecticides

Phytochemical is defined as any organic substance or chemical constituent obtained from plants ('phyto' in Greek for plants). However in scientific literature, phytochemical is commonly used to describe the biologically active molecules in plants that are not classified as vitamins or nutrients [12, 13]. Phytochemicals also refer to chemical active ingredient of plants. The subject of phytochemistry deals with the chemical structures of the substances, their biosynthesis, turnover and metabolism, their natural distribution and their biological function [14]. Natural products can be classified into two major groups based on the metabolic pathways and the function of the substances themselves [15]. Plant chemicals or phytochemicals are classified as either primary or secondary metabolic products depending whether they play an essential role in plant metabolism and are universally present in all plants [16, 17]. Primary metabolism supplies all the necessary tools (building blocks and energy) in order to enable the organisms to live. While, the term 'secondary products' or 'secondary metabolites' are applied to plant products that have no apparent role in a growth and development of the plant [18, 19] but contribute toward plant's toxins accumulation and feeding deterrents against pests. Primary metabolites include common sugars, protein amino acids, purines and pyrimidines of nucleic acids and chlorophyll. In contrast, secondary metabolites include a variety of phytochemical families or groups and its common sources such as flavonoid (e.g.: berries, herbs and vegetables); isoflavones or phytoestrogens (e.g.: barley and soy); isothiocyanates (e.g.: cruciferous vegetables); monoterpenes (e.g.: citrus peels and essential oils); organosulfur compounds (e.g.: chives, garlic and onions); saponin (e.g.: beans, cereals and herbs); capsaicinoids (e.g.: chilli peppers) and phytosterol (e.g.: vegetable oils). The phytochemical families or

groups above are originated respectively from three major compounds which are alkaloids (derived from amino acid, the building block of proteins); terpenes (a group of lipids) and phenolics (derived from carbohydrates). However, in the light of present day knowledge, this variation is subjective as there is no sharp division between the two metabolites [16]; [17]. Figure 1 shows the basic metabolic pathway in plants.

The less abundant secondary plant metabolites on the other hand, have apparently no function in the plant metabolism and often derived from the primary metabolites as a result of the chemical adaptation to environmental stress. These chemicals serve as chemical defenses against pest infestations. Furthermore, the chemical defensive system is also called as 'allelochemicals' in which the adapting ability derived from the production of special chemicals of secondary plant substances [20]. Some of the higher plants are storehouse of extractable secondary metabolites and usually sufficient to be economically viable as raw materials for the development of botanical pesticides as well as for pharmaceutical and other beneficial applications. Such pesticidal, natural raw materials also provide stimulus for structural modification and optimization of the lead molecules to obtain more effective crop protection chemicals. On top of that, as estimated from approximately 250,000 higher plant species, very few have been surveyed and most remain unexploited and unutilized for insecticidal active principles [10].

### 1.2 Organic Pesticides

Little attention has been paid to various other organic farming treatments. It is asserted that organic pesticides are unstable, biodegradable, environmentally friendly, and that their external application on crops is a safe practice. Most such chemicals, however, have not received proper biological investigation in terms of their impact on human health [21], although some may carry previously unrecognized risks (Table 1).

### 1.3 Plant Growth, Development and Ecology

*Derris* is a small shrub originating in the tropical rainforests of Malaysia. It grows in lowland areas and does not thrive at higher altitudes. It is the roots, which contain the active substances, mainly rotenone [11, 22].

Grown in the shade *Derris malaccensis* requires a period of 1½ years to 2 years for it to produce a worthwhile content of rotenone. However grown in full sunlight, it needs only nine months for the roots to develop sufficiently. Meanwhile, *Derris elliptica* required 26 months for the maximum development of the rotenone. It can propagate vegetative and fully developed after six weeks. The crop is harvested by exposing the shallow roots and cutting off those with a diameter of 2 cm to 6 cm wherein this range of diameter have the highest yield of rotenone (mg). In fact, it thrives on many soils but particularly on loams and clays [11].

*Derris elliptica*, or 'tuba' as it is known locally is an insecticidal plant that has been known to be used as bio-pesticide. 'Tuba' plant is a kind of woody creeper plant and climber. *Derris* is a climbing plant of Southeast Asia and its roots contain rotenone, a strong insecticide.[23] It needs at least 75% soil moisture content and the surround temperature should be approximately 25 to 30 °C to obtain high yield of the rotenone (mg) during its development. A calm area with low acidity soil content enhances the production of rotenone [24]. In Malaysia, 'tuba' plants can be found abundantly in the area of palm oil and rubber plantations. Many Malaysians farmers do not realized the potential of this particular plant [25]. This plant actually possess a great knockdown effect to the pest especially in the order of Homoptera (e.g.: Diamondback moth; *Plutella xylostella* Linn.) [26]. Figure 2 shows the species of *Derris elliptica* and *Derris malaccensis* that can be easily found in the peninsular of Malaysia. *Derris elliptica* or locally known as 'tuba kapur' can be easily found on laterite or clays soil. Meanwhile, *Derris malaccensis* or locally known as 'tuba gading' can be found on peat soil [27]. Both of the species are extremely different in term of the amount of fine and coarse roots collected during the pre-processing treatment wherein *Derris malaccensis* procured more fine and coarse roots as well as the yield of rotenone as compared to *Derris elliptica*.

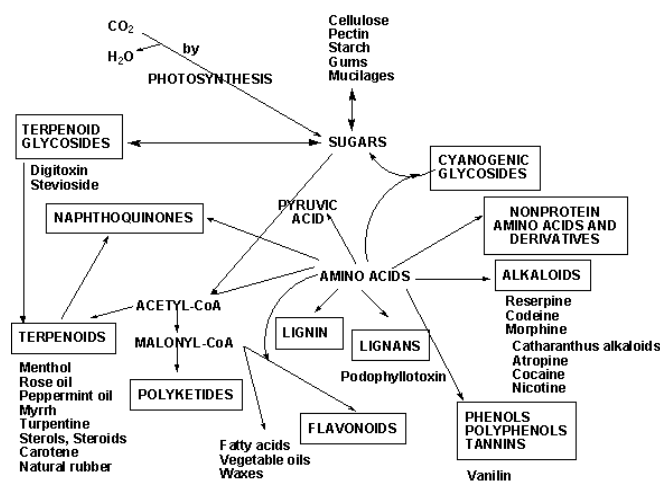

**Figure 1** Biosynthetic origins of some commercially important plant-derived compounds. Major groups are indicated by boxes [17]

**Table 1** The health risks of some organic pesticides

Properties and/or adverse effects	Reference
<b>Rotenone (insecticide)</b>	
Causes death in fish	[28]
Inhibits the electron transport chain	[29]
Induces hepatocyte apoptosis	[30]
Induces Parkinson's disease	[31]
<b>Bacillus thuringiensis spores (insecticide)</b>	
Long-term environmental persistence	
Cause lung inflammation, internal bleeding and death in laboratory mice	[32]
Infect wounds and damage human cells in culture	[33]
Produce <i>Bacillus cereus</i> -like cytolytic toxins	[34]
<b>Natural pyrethrins (insecticide)</b>	
Some are as neurotoxic as synthetic pyrethroids	
Residues of both types have been detected in foods	[35]
They are less effective than pyrethroids and have to be used at higher doses	[37]
<b>Sodium fluoride (pesticide)</b>	
Accumulates in soil, plants, wildlife, and human consumers, and may be toxic for sensitive human populations	[38]

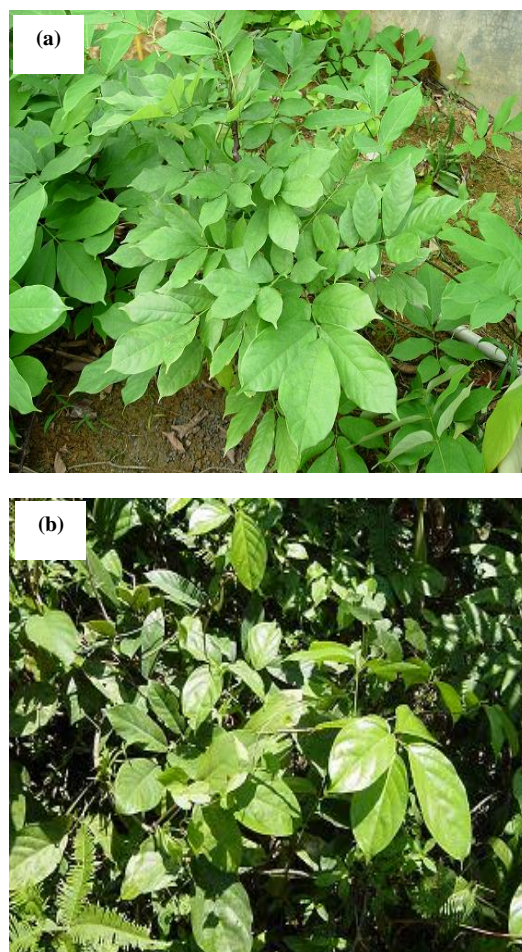

**Figure 2** *Derris* species that abundantly available in the Peninsular of Malaysia: (a) *Derris elliptica* and (b) *Derris malaccensis* [27]

#### 1.4 The Cultivation Condition of *Derris elliptica*

In Malaysia, the suitable areas to grow and develop *Derris elliptica* is in the area of palm oil and rubber plantation with a loam and laterite soil [27]. In the province of Soc Trang, Vietnam, *Derris elliptica* grows at the area of coastal sloppy with a sandy soil like in Delta Mekong [39]. In Vietnam, the development of *Derris elliptica* for transplanting and harvesting are prepared in the late rainy season with the aim to obtain high yield of rotenone. Unfortunately in Malaysia, this plant is not as important in Vietnam in which they have been implemented and established the cultivation techniques and technological process [39, 40], to produce different preparations of the insecticide products (e.g.: emulsion concentrates, water milk and water-soluble powder preparations). Therefore, there is no initiative from the Malaysian farmers to cultivate and use this plant as an effective botanical insecticide although it has been scientifically proven to kill insect pests with no major environmental problems. Furthermore, in the cultivation techniques of *Derris elliptica* roots, this plant usually yielded approximately 1.8 to 3.4 times in the appropriate NPK application treatment as compared to the control treatment [41]. The preliminary researches on the formation, translocation, and accumulation of rotenone in the *Derris elliptica* Benth conducted by Hein et al. [41], has showed that the yield of rotenone (mg) has the co-variations with their precursors such as phenylalanine and methionine from the young to the old leaves. In this stage, the biosynthesis of phenylalanine, methionine and rotenone have the co-variations with the photosynthetic rate. In contrast, from the old leaves to stems and roots are contrary. In fact, phenylalanine and methionine content decreased about 50% while the yield of rotenone increased many times and offered the highest in the roots. The experiments cutting sieve-tube for blocking the transportation of solutes in the phloem vascular demonstrated that after biosynthesizing in leaf, rotenone translocated downwards to the lower organs by the phloem route and eventually accumulates in the root. Observing the structure of the phloem and xylem gave an initial explanation on the mechanism of 'load' at the phloem cell source and 'unload' at the xylem cell sink of rotenone in the *Derris* root. This is the way on how to increase the *Derris* root yield and yield of rotenone (mg) at the plantation fields [42]. Table 2 and Table 3 show the existence of rotenone by different analysis methods and the amount of methionine, phenylalanine and rotenone analyzed by reversed-phase HPLC. Figure 3 shows the species of *Derris elliptica* roots and stems.

#### 1.5 Current Development on the Cultivation of *Derris elliptica*

Currently, the intercropping model with other plant species such as *Allium ascalonium* (onion shrub plant) was recommended to overcome the shortage of *Derris* roots due to *Derris* monoculture habit by farmers in Vietnam [39]. This technique can

also be utilized and implemented in Malaysia due to advance facilities of the tissue culture laboratory as compared to the other Asia countries. The intercropping model gained a lot of advantages such as root's biomass yield and yield of rotenone (mg) increase 24% to 27% as compared to the monoculture model. In contrast, production expenditure of *Derris* in the former decreases 15% to 20% as compared to the latter. Eventually, total profit of the intercropping model obtained 3.15 times as compared to the control (*Derris* monoculture). In addition, the new advanced model has been applied largely and effectively in Soc Trang province of Vietnam and has proven to acquire high yield of rotenone [43]

**Table 2** Existence of rotenone in *Derris elliptica* Benth plant's organs determined by different analysis methods [41]

<b>Derris plant's organs</b>	<b>By Irwin Hornstein's Titration Method</b>	<b>By Colorimeter UV-VIS Method</b>	<b>By Weigh Measure D. C. Beach Method</b>
Young leaf	0.79% (w/w)	0.39% (w/w)	0.54 mg
Old leaf	1.36% (w/w)	0.77% (w/w)	1.21 mg
Branch	1.77% (w/w)	1.50% (w/w)	1.69 mg
Stem	2.21% (w/w)	1.74% (w/w)	1.91 mg
Root's core	9.94% (w/w)	11.96% (w/w)	10.32 mg
Root's bark	5.56% (w/w)	5.80% (w/w)	4.71 mg

**Table 3** Rotenone, methionine and phenylalanine in different organs of *Derris* plant analyzed by reversed-phase HPLC [41]

<b>Derris plant's organs</b>	<b>Methionine; mg/100 g</b>	<b>Phenylalanine; mg/100 g</b>	<b>Rotenone; % (w/w)</b>
Young leaf	1.98	27.90	0.39
Old leaf	12.97	51.70	0.77
Stem	8.90	21.90	1.74
Root	5.90	26.90	11.60

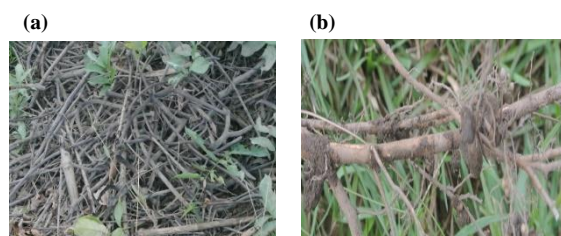

**Figure 3** *Derris elliptica* plant parts (a) stems and (b) roots [27]

## 2.0 PHYTOCHEMISTRY OF DERRIS SPECIES

### 2.1 Rotenone as a Principal Bio-active Constituent

*Derris elliptica* and *Derris malaccensis* contain approximately 4% (w/w) to 5% (w/w) rotenone while *Lonchocarpus utilis* and *Lonchocarpus urucu* contain approximately 8% (w/w) to 10% (w/w) rotenone in dried roots [10]. Rotenone comprises of an isoflavone nucleus with an isoprene moiety attached at C-8 of ring A as shown in Figure 4 [44]. In addition, these plants contain number of other isoflavonoids compound such as deguelin, 12 $\alpha$  $\beta$ -rotenolone, tephrosin, elliptone, sumatrol, toxicarol, malaccol and etc. [10] which are toxic or induce behavioural or physiological effects. Low in mammalian toxicity, rotenone is mainly active as a contact or stomach poison. This isoflavonoid is extremely toxic to cold-blooded animals (especially fish) [45] and piercing-sucking insect such as aphids, red bugs, chewing insects especially caterpillars upon plants, external parasites such as fleas and lice [46], but less active in birds and higher animals [47]. In fact, rotenone can enter the insect body through the alimentary canal, tracheae or integument. It appears to kill insects by specific inactivation of the respiratory enzyme, glutamic acid oxidase resulting in death through oxygen (O<sub>2</sub>) starvation [46]. Due to its low toxicity when ingested, fishes stupefied by rotenone can be consumed by humans without any adverse reaction [48]. Furthermore, rotenone has three major advantages: (1) humans can digest it relatively safe (2) they are harmless to plants (non phyto-toxic) [11] and (3) it is unstable in light and heat, losing almost all its toxicity after two to three days [45, 49].

### 2.2 Physico-chemical Properties of Rotenoids

Five compounds have been isolated and characterized from the chloroform extract which are deguelin, tephrosin, rotenone, 12 $\alpha$  $\beta$ -rotenolone, 12 $\alpha$ -hydroxyrotenone [50]; [51]; [52]; [53]. Therefore, there is a number of toxic constituents that have been isolated from the roots and seeds of *Derris* species and the most important of which is rotenone with a chemical name of 1,2, 12 $\alpha$ -tetrahydro-8,9-dimethoxy-2 (1-menthylethenyl)-(1) benzopyrano (2,4-b) furo (2,3-h) (1) benzophyrano-6 (6H)-one with melting point (m.p) of 163 °C [54]. Rotenone has the following molecular structure as shown in Figure 4.

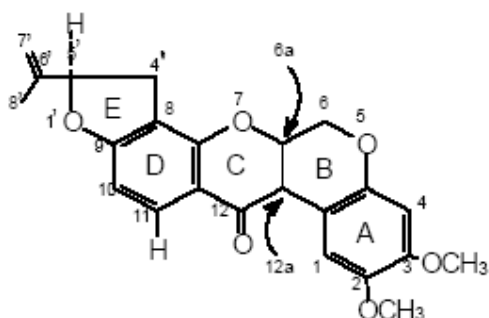

Figure 4 Rotenone molecular structures [44, 54]

Rotenone, with an empirical of C<sub>23</sub>H<sub>22</sub>O<sub>6</sub>, is an isoflavonoids compounds with a molecular weight of 394.41 g/mol [55]. It consists of 70.04% carbon, 5.62% hydrogen and 24.34% oxygen. It melts at 156 °C to 166 °C. Rotenone is very soluble in a number of organic solvents like alcohol and acetone, but is practically insoluble in water. According to Kidd and James [54] rotenone is slightly soluble in water with the amount of 15 mg/L at 100 °C. Besides that, the other naturally occurring rotenoids are elliptone with melting point of 159 °C which has a furan ring in place of the ring B of rotenone; sumatrol with melting point of 188 °C which is 15-hydroxyrotenone; malaccol with melting point of 244 °C, which is 15-hydroxyelliptone; toxicarol with melting point of 101 °C, which has a hydroxyl group at carbon 15 (\*); and deguelin with melting point of 165 °C to 171 °C which has a hydrogen atom on carbon 15 (\*) in place of the hydroxyl group of toxicarol. A related material, tephrosin with melting point of 197 °C to 198 °C has a hydroxyl group on one of the carbon atoms between rings A and C. It does not occur naturally in *Derris* resin but it is an oxidation product of deguelin. All the naturally occurring rotenoids appear to exist as levo forms. Furthermore, the toxicity level (LC<sub>50</sub>) of rotenoids resin against targeted organism is largely unexplored, but individually rotenone is five to ten times as effective as compared to the other rotenoids. In addition, the yield of rotenone and total extractives (rotenoids resin) in the various commercial plant species are variable. For example, the roots of *Derris elliptica* consist in approximately 5% (w/w) to 13% (w/w) rotenone with total ether extractives of approximately 31% (w/w). *Derris malaccensis* consist in approximately 4% (w/w) rotenone with total extractives of 27% (w/w) and *Lonchocarpus utilis* consist in approximately 8% (w/w) to 11% (w/w) rotenone with total extractives of 25% (w/w). When exposed to light and air, rotenone decomposes by changing from colourless through yellow to deep red and resulting in non-insecticidal products. As for that reason, rotenone preparation should be protected from light and heat during handling and storage. Additionally, rotenone is readily oxidized in the presence of alkaline to dihydrorotenone by eliminating two hydrogen atoms to form a double bond between rings A and C [56, 57]. This material is less toxic than rotenone, which should therefore be considered incompatible with alkaline dusts such as lime and soaps and other alkaline wetting and spreading agents [46]. Moreover, pure crystalline rotenone is prepared by extracting the powdered roots with a solvent such as ether or carbon tetrachloride and concentrating the solution to produce crystal. Table 4 shows the solubility of pure rotenone in selected organic solvents at 20 °C [46].

**Table 4** The solubility of pure rotenone at 20 °C<sup>a</sup> [46]

Solvent	Solubility (g/100 ml) <sup>a</sup>
Water	0.00002
Ethyl alcohol (Ethanol)	0.2
Carbon tetrachloride	0.6
Amyl acetate	1.6
Xylene	3.4
Acetone	6.6
Benzene	8.0
Chlorobenzene	13.5
Ethylene dichloride	33.0
Chloroform	47.2

### 2.3 Degradability of Rotenone

Rotenone is unstable and the length of its degradation depend on many factors including light, temperature, turbidity, depth, presence of organic debris and dose [57].

#### 2.3.1 Rotenone Stability in Water

Rotenone is generally unstable and degrades rapidly in water. It has been shown to degrade as fast as within fortnight of application [56] but can also persist for periods up to five month [58, 59]. Despite all the factors that go into rotenone degradation, Schnick [56] has reported that waters should still detoxify within five weeks of the treatment. Rotenone is photochemically unstable and readily breakdown in the presence of light [54]. Light oxidatively decompose rotenone into non-toxic dihydrorotenone and water [56, 57]. This degradation process occurs at the quicker rate in the presence of high water temperature. According to Grinda *et al.* [24], one of the advantages of rotenone is its rapid detoxification under natural conditions. In general, high alkalinity (more than pH 8 to 9), high temperatures (possibly more than 40 °C) [60], abundant light and air and low concentrations favor rapid detoxification of rotenone. The most apparent chemical or physical property of the water which affects the breakdown of rotenone is temperature. Table 5 shows variety of temperature condition in water to affect the rotenone dissipation. Temperature appears to affect the breakdown of rotenone the most. As for that reason, Dawson *et al.* [61] concluded that higher water temperature would readily facilitate the degradation of rotenone faster than lower water temperature. A variety of rotenone concentration (ppm) also affected the detoxification of rotenone. Table 6 shows variety of rotenone concentration to affect the detoxification process of rotenone.

**Table 5** Time of rotenone dissipation versus temperature [24]

Temperature (°C)	10	15	20	25
Dissipation time (days)	26	14	7	4

**Table 6** Detoxification time of varies rotenone concentration [24]

Concentrations (ppm)	1	4	8
Detoxification time (days)	2	4	7

Turbidity and organic debris in water act by slowing down the decay of rotenone. It has been shown that rotenone absorb to the sediment and organic particles and persist for longer periods of time [61]. High turbidity also corresponds to the low light penetration into water, which allows rotenone to be degraded at a slow rate. Depth of water also plays a role in the breakdown of rotenone. Rotenone tends to breakdown more readily in the shallow epilimnion of water bodies [57]. Furthermore, Wu *et al.* [56], has reported that each increase in depth of 1 ft (0.31 m) in a pond increased the length of rotenone toxicity by two days. Not only the epilimnion has usually warmer than the deeper hypolimnetic waters, but it also got lighter than hypolimnion. These two factors act to increase the rate at which rotenone degrades in such waters. As mentioned earlier, the early studies of rotenone degradation has showed that rotenone break down into two simple products namely as non-toxic dihydrorotenone and water [57]. Dihydrorotenone with melting point of 216 °C is about as toxic as rotenone to many insects and it is more resistant to the decomposition of sunlight. Further study by Cheng [62], using photo-degradation, they have identified that rotenone decomposes to at least 20 degradation products, most of which are rotenoids. They have reported that only one product is fairly toxic namely as 12 $\alpha$  $\beta$ -rotenolone. The fact that other 19 or more degradation product is not toxic is one of the reasons rotenone can be used safely as an environmental-friendly insecticide.

#### 2.3.2 Rotenone Stability in Soil and Ground Water

Rotenone is rapidly broken down in soil and in water. The half-life in both of these environments is between one and three days respectively [63]. It does not readily leach from soil [63] and it is not expected to be a groundwater pollutant. Rotenone breaks down readily by exposure to sunlight [54]. Nearly all of the toxicity of the compound is lost in five to six days of spring sunlight or two to three days of summer sunlight.

#### 2.3.3 Rotenone Stability in Vegetation

Rotenone is a highly active but short-lived photosensitizer. This means that an organism consuming the compound develops a strong sensitivity to the sun for a short time [39]. A number of photodecomposition products are formed when

bean leaves are exposed to light. It is also sensitive to heat, with much of the rotenone quickly lost at high temperatures.

#### 2.4 Types of Rotenone Formulation

The extract of *Derris* sp. which contains rotenone and other toxic constituents can be formulated and used in many form of insecticide products namely as:

- (1) Dusts of ground *Derris* roots are mixed with 3 parts to 7 parts of carrier such as talc, clay, gypsum, sulphur and tobacco or walnut shells ground to pass a 250 mesh to 350 mesh sieves. Furthermore, the impregnated dusts are also used and produced by mixing the extract of ground *Derris* roots in a volatile solvent with an adsorptive carrier. The solvent is then evaporated, leaving each dust particle coated with the insecticide. This preparation is more uniform in particle size as compared to the initial preparation of the ground *Derris* roots dust. Dusts containing 0.5% (w/w) to 1% (w/w) rotenone and 1.8% (w/w) to 3.5% (w/w) total extractives are effective against most insects controlled by rotenone and should be used at 15 lb<sub>m</sub> (6.8 kg) to 25 lb<sub>m</sub> (11.3 kg) per acre on such crops of cabbage and celery. On top of that, alkaline carriers such as lime should not be used with rotenone [46].
- (2) Dispersible powders may be made from finely ground *Derris* roots. Two to five pounds (0.9 kg to 2.3 kg) of *Derris* powder with 2 pounds (0.9 kg) of neutral soap or the equivalent of the sulfonated oil will make 100 gallons (380 L) of spray. For the small amount, an ounce of 4% (w/w) to 5% (w/w) rotenone dust and a teaspoonful of spreader should be used in 2 gallons (7.6 L) of water.
- (3) The extract of *Derris* is also widely used as dried resin which contains 25% (w/w) to 35% (w/w) rotenone. This dried resin is usually used as emulsifiable concentrates (EC) or known as spray oils. Because of the limited solubility of rotenone in spray oils which is approximately 0.05% (w/w), mutual solvents are generally employed to increase the solubility to practical limits. Materials which have been employed for this purpose are dibutyl phthalate, methylated naphthalenes, alkylated phenols and high boiling ethers. The concentrated solutions may either be used as fly and cattle spray or emulsified in water as agricultural sprays. Rotenone concentrates containing 1% (w/w) rotenone and 3.5% (w/w) to 4% (w/w) total extractives may be diluted 1 part to 600 or 800 parts of water. For aphids, the rotenone concentrates may be diluted 1

part to 800 parts of water which contain rotenone approximately 0.00125% (w/w).

### 3.0 PHYTOCHEMICALS EXTRACTION METHODS

It is important to understand the background of the herbal extraction processes and to discover the correlation between the operating conditions, the yield obtained as well as the toxicity level of the extract [64]. Herbal extraction processes are used to produce herbal extracts from the herbal raw material in several forms. These include the extracts which contain the soluble constituents, oleoresins which contain the volatile and non-volatile constituents and essential oils which only contain the volatile constituents from the plant material [16, 18]. Herbal extract could be defined as a compound mixture obtained from the fresh or dried plant or parts of the plant such as leaves, flowers, seeds, roots and barks by different extraction procedures. Normally, the active constituents are obtained together with other materials present in the vegetal mass such as resins, fats, waxes, chlorophyll and colouring materials. Moreover, the extraction of bio-active components from the vegetal materials is an essential part of the nutraceuticals, pharmaceuticals, cosmeceuticals and phytochemical bio-pesticide industry [65-67]. Several methods are available to obtain extracts from the vegetal materials, Table 7 [66, 68, 69].

Nowadays, three promising technologies that are expended and applied in the pharmaceuticals, cosmeceuticals, food industries and agriculture for pest control are Supercritical Fluid Extraction (SFE), Accelerated Solvent Extraction (ASE) and Ultrasonic Assisted Extraction (UAE). Supercritical Fluid Extraction (SFE) utilises a supercritical fluid such as carbon dioxide (CO<sub>2</sub>) to extract the phytochemical of interest from the plant matrix [70-72]. By varying the temperature and pressure, the permeability and solubility of the supercritical fluid is varied and can be adjusted to extract and precipitate the specific compound of interest. However, due to the high cost of operation as well as the consumer preference of whole herbal extract approach to phytochemicals processing, this method is rarely used. The high-pressure liquid extraction method has been developed to use conventional fluids under higher pressure and temperature conditions. A solvent such as ethanol is heated under high pressure to enhance the solvent permeation and solute solubility during extraction process. This method also known as Accelerated Solvent Extraction (ASE) has reduced the extraction time significantly as well as produced high yield of the extract [73, 74]. Unfortunately, it is currently utilized only on a small laboratory and analytical scale due to high maintenance and operating cost. Lastly, the Ultrasonic Assisted Extraction (UAE) has been utilized to enhance the conventional extraction method such as percolation and maceration. It is found that the application of ultrasonic waves during the extraction process does increase the



yield and helps to reduce the extraction time under certain condition [66].

### 3.1 Extraction Mechanism

Vegetal tissue consists of cells surrounded by the walls as shown in Figure 5. The extraction mechanism involves two types of physical phenomena:

1. Diffusion through the cell walls.
2. Washing out (rinsing) the cell contents once the walls are broken.

Currently, the Ultrasonic Assisted Extraction (UAE) is the most preferable unconventional method used to extract high yield of bio-active constituents either in the aqueous extract, essential oil or oleoresin. In fact, both phenomena above are significantly affected by the ultrasonic irradiation of the Ultrasonic Assisted Extraction (UAE) as compared to the other unconventional method. Theoretically, some cells that existed in the form of glands (external or internal) are filled with essential oil or oleoresin [66]. A characteristic of such glands (when external) is that their skin is very thin and can be very easily destroyed by any method of extraction such as sonication. Thus, the extraction of essential oil as well as fat oil (oleoresin) is facilitated by sonication. Moreover, the milling degree of the vegetal material plays an important role for the internal glands. It is obvious by reducing the size of the vegetal material particles will increase the number of the cells directly exposed to extraction by solvent. This effect can be utilized by milling the material before extraction [66].

### 3.2 Principles of Solid-liquid Extraction

Solid-liquid extraction involves a mass transfer from one phase to another or in other words it is concerned with the extraction of a soluble constituent from a solid by means of solvent. Solid-liquid extraction is also known as leaching [68, 69, 75].

#### 3.2.1 Types of Solid-liquid Extraction

There are several types of solid-liquid extraction such as percolation, infusion or maceration and countercurrent extraction method (soxhlet). For this particular study, the maceration method is employed due to its simplicity to handle and collect the samples. Furthermore, infusion are prepared by leaving the plant material to soak in the solvent generally at room temperature for a period of time with or without intermittent shaking, followed by the filtration to separate the plant debris [69].

### 3.3 Desirable Features for the Extracting Solvent

There is no such thing as 'universal solvent'. The solvent extraction is unique for each separation problem. Among the desirable features for the extracting solvents are high capacities for the

species being extracted into it, selective in dissolving the desired compounds, low mutual solubility with water, easily generated, have suitable physical properties such as density, viscosity and surface tension and relatively inexpensive, non-toxic and non-corrosive [76].

### 3.4 Leaching Process (Solid-liquid Extraction)

Many biological, inorganic and organic substances occurred in a mixture of different components in a solid. In order to separate the desired solute constituent or remove undesirable solute components from the solid phase, the solid is contacted with a liquid phase. The two phases are in intimate contact and the solute or solutes can diffuse from the solid to liquid phase, which causes the separation of the components originally in the solid. This process is known as leaching [77].

**Table 7** Extraction methods used in the phytochemical industry

Extraction methods	Types of extraction
Distillation	a) Direct essential oil distillation b) Water steam distillation c) Water and steam distillation
Conventional extraction technique or solvent extraction	a) Solvent extraction (percolation) b) Maceration with solvent or Normal Soaking Extraction (NSE) c) Boiling with water (infusion)
Non-conventional extraction technique	a) Supercritical Fluid Extraction (SFE) b) Vortical or turbo extraction c) Extraction by electrical energy d) Ultrasonic Assisted Extraction (UAE) e) High-pressure liquid extraction (Accelerated Solvent Extraction)

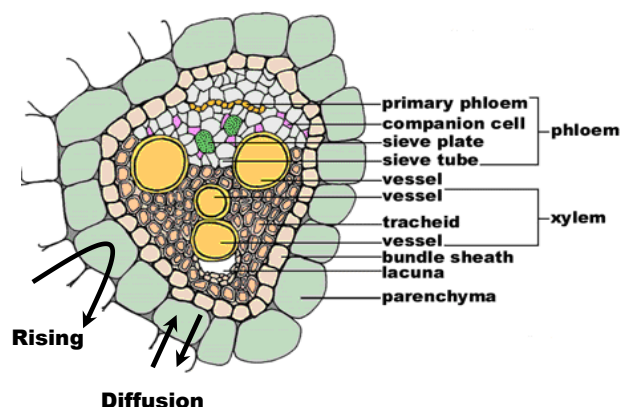

**Figure 5** Schematic diagram of vegetal cell structures [66]

Leaching is concerned with the extraction of a soluble constituent from the solid by means of solvent. The process can be used for the production of a concentrated solution of a valuable solid material. As far as the amount of soluble constituent present, its distribution throughout the solid determines the method used for the leaching process. If the solute is uniformly dispersed in the solid, the material near the surface will dissolve first, leaving a porous structure in the solid residue [77]. The solvent will then have to penetrate this outer layer before it can reach further solute and the process will become progressively more difficult and the extraction rate will fall. If the solute forms a very high amount of the solid, the porous structure may break down almost immediately to give a fine deposit of insoluble residue and the access to the solute will be difficult and need for further treatment [66, 77]. Generally, the process can be considered in three parts:

1. The change of phase of solutes as it dissolves in the solvent.
2. Diffusion through the solvent in the pores of solid to the outside of the particle.
3. The transfer of the solute from the solution in contact with the particles to the main bulk of the solution.

These processes may be responsible for limiting the extraction rate, though the first process usually occurs so rapidly that it has negligible effect on the overall rate of the extraction process. In the biological and food processing industries, many products are separated from their original structure by the leaching process. One of the important processes is the use of organic solvents such as hexane, acetone and ether to extract the oil from peanut, soybean, flax seeds, castor beans and sunflower seeds [77]. In the pharmaceutical industry, many different pharmaceutical products are obtained by leaching plant roots, leaves and stems.

Biological materials such as *Derris* root are cellular in structure and the soluble constituents are generally found inside the cells. The rate of leaching may be moderately slow because the cell walls provide another resistance to diffusion. As for the leaching of bio-active constituents such as rotenone from the leaves, stems and roots, drying and milling of the plant materials before extraction helps to rupture the cells walls so that the resistance of diffusion can be minimized [66].

#### 4.0 NEW APPROACH: IONIC LIQUIDS AS SOLVENTS FOR ROTENONE EXTRACTION

Ionic liquids (ILs) are an organic salt in the liquid state under ambient temperature comprised of normally charge-stabilized organic cation paired with either an organic or inorganic anions. It displays a wide range of unique properties such as high thermal stability, non-flammability, insignificant vapour pressure, and low chemical reactivity. In

addition to that, ILs also have fine tunable density, viscosity, polarity and miscibility with other common solvents [78]. Commonly studied cations of ionic liquids (ILs) include 1-alkyl-3-methylimidazolium ( $[C_n\text{mim}]^+$ ), N-alkylpyridinium ( $[C_n\text{py}]^+$ ), tetraalkylphosphonium and tetraalkylammonium. These cations can be paired with either organic or inorganic anions such as halide, acetate, hexafluorophosphate, tetrafluoroborate, trifluoromethylsulfonate, nitrate or others. Innumerable molecular combinations are theoretically possible (greater than  $10^{18}$ ) [79] with various combinations of cations and anions affording distinct physicochemical properties such as melting point, polarity, viscosity, stability, solvation properties and phase behavior of ILs. Ionic liquids (ILs) can be used as green solvents to replace volatile organic solvents, thus reducing environmental pollution [80]. For instance, a research done by Guo et al. [81], discovered that an increase in flavonoid solubility in ILs can lead to selectivity toward specific anions thus helps increasing the exhaustive yield of bio-active compounds. However, there are also some flaws in using ILs as solvents for plants extraction. This is because ILs have relatively high polarity due to their charged and asymmetric structures [82], by which they do not have good affinity with weak-polar compounds and causes reduction in the distribution of weak-polar compounds into ion ILs phase. Although longer alkyl chain of ILs has lower polarity, its viscosity is high and this impaired the mixing and transfer properties of extraction process by influencing the dissolution of compounds in ILs. However, mixture of ILs and polar molecular solvents as extraction solvents could be effective approach to solve the flaws of ILs.

The addition of miscible molecular solvents as co-solvent helps to break the microscopic hydrogen-bond network and the aggregation of ILs, which significantly reduce the viscosity of ILs and improve the mixing and transfer process in ILs mediated extraction [83, 84]. The finding has been proven as ILs was added to the main organic solvent (acetone) as an additive to increase the yield of rotenone [85]. The additions of various molecular solvents help to create wide adjusted range of solvents polarity, hydrophobicity, hydrogen-bond acidity and basicity which facilitates high selectivity of ionic liquids (ILs) towards some bioactive constituents due to various interaction including hydrogen-bonding, hydrophobic interactions and dispersion interactions [86, 87].

#### 4.1 Extraction of the Rotenone and Rotenoids Resin: Pilot Plant to Industrial Scale Production

The mass production of high quality and amount of rotenone in rotenoids resin has been developed since 1980's by the European company called SAPHYR S. A. R. L. (France). According to [24], they have invented a method that extract the insecticidal materials contain in the plants by means of liquid which entirely harmless, both to man and to animals. The method developed

successfully extracted rotenone with the highest yield using the alkyl esters (butyl, hexyl and octyl esters of fatty acids) up to approximately 36% (w/w) in the cube rotenoids resin. According to this invention that have been released on the USPTO PATENT 1987, the extraction process is initially done using 100 g of finely crushed *Derris* powder into a 250 ml of extraction vessel provided with agitator. The finely crushed *Derris* powder is soaked with 25 g of octyl stearate and 160 g of methylene chloride. The solvent-to-solid ratio of methylene chloride and octyl stearate mixture is approximately 2 ml/g. After agitating for half an hour at 45 °C, the treated powder is separated from the Liquid Crude Extract (LCE) by filtration and washed on the filter with 50 g of methylene chloride. The Liquid Crude Extract (LCE) is introduced into a round-bottom flask with reflux condenser, in which the methylene chloride is distilled so as to recover it. Finally, 39 g of rotenoids resin is produced with 36% (w/w) rotenone and 64% octyl stearate. It is observed that the yield of rotenoids resin and rotenone in finely crushed *Derris* powder of this product is 39% (w/w) and 14% (w/w) respectively. By diluting this product with an equal volume of octyl stearate, a 7% (w/w) rotenone solution is obtained which can be used directly as an insecticide composition. A fraction of the viscous product is emulsified in the presence of surface active agent with 10 times its volume of water to serve as spray for plants in order to combat against targeted insects.

Meanwhile, a method of extracting rotenone with fewer chemicals, economically viable and environmental-friendly was investigated by Institute of Bioproduct Development (IBD) researchers. This new approaches are crucial due to the yield of rotenone (mg) extracted from the Malaysian species (*Derris elliptica* and *Derris malaccensis*) were considered lower than the commercially available product [51]. Therefore, the main consideration was to avoid as much as possible thermal degradation that might occurred in the production line and to find out the right solvent

that could extracts more rotenone apart from using environmental-friendly process system. Acetone and ethanol were the appropriate organic solvents that suite with the requirement and also have the capability to extract large amount of rotenoids resin (mg) as well as the rotenone content (mg). The rotenone extraction methods that can be found from 1930 to 2003 are summarized and shown in Table 8.

A process flow diagram of pilot plant scale is shown in Figure 6 comprises of a few stages. It started with a selection and harvests the roots conforming to the specifications to assure high purity of rotenoids resin and total extractives. The roots were chopped to the correct size before been fed onto the extraction vessel. An appropriate amount of oxalic acid, deionized water (DIW) and ethanol (acetone was the most preferable solvent to extract more rotenone) were charged into the extraction vessel. The extraction process was carried out for about 12 hrs [88, 89]. After the extraction cycle completed, the Liquid Crude Extract (LCE) from the extraction vessel was transferred to the intermediate holding tank using the transfer pump and strainer. Using the same pump and fine strainer, the extract was transferred to the evaporator unit for the recovery of solvent.

The essential step for this recovery unit is to avoid any thermal degradation that could occur during the concentration process. For that reason, high vacuum pressure pump was utilized. This is to assure that the minimum operating temperature of 40 °C have a sufficient heat and vacuum pressure to evaporate solvent as quicker as possible at maximum rate of the solvent recovery [60]. Finally, the product was discharged to another storage tank of the Concentrated Liquid Crude Extract (CLCE). On top of that, the polyolefin containers are used for storages, protecting the products against excess heat and light.

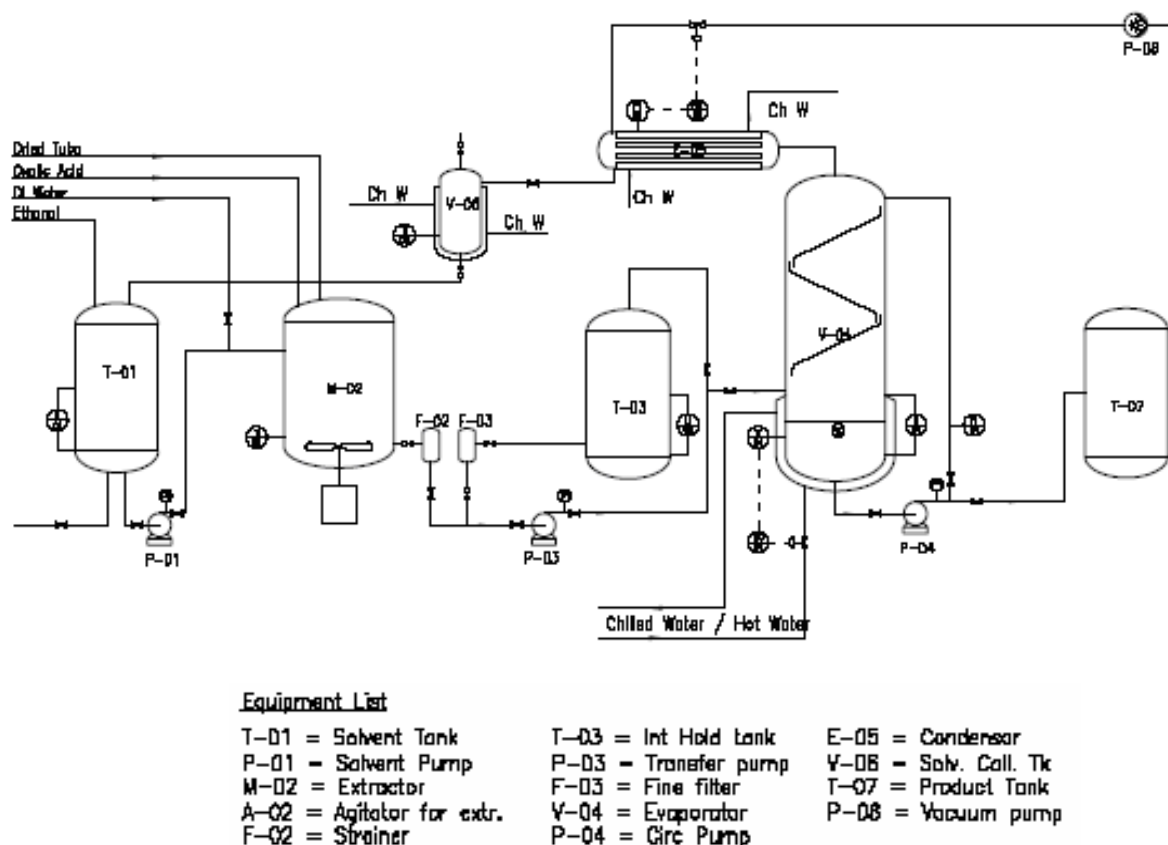

Figure 6 Layout of the pilot plant scale production of the rotenone Concentrated Liquid Crude Extract (CLCE) [27]

## 5.0 TOXICOLOGY OF BOTANICAL EXTRACT

Toxicology is the science that deals with the study of adverse effects chemicals or physical agents may produce in living organisms under specific conditions of exposure. It is a science that attempts to qualitatively all the hazards, for example the organ toxicities that

associated with a substance as well as to quantitatively determine the exposure conditions under which those hazard or toxicities are induced [90, 91]. Toxicology is the science that experimentally investigates the occurrence, nature, incidence, mechanism and risk factors for the adverse effects of toxic substances [91].

Table 8 Rotenone extraction methods

SOURCES	SOLVENT USED	REMARKS	CLAIM
[92]; US-Patent	Mesityl oxide oxalate, n-butyl ester	U.S. Patent No.: 2,149,917 METHOD: Unknown	The extract is a red-yellow colour and contains approximately 0.8% (w/w) rotenone
[93]; US-Patent	90% carbon tetrachloride and 10% dichloro diethylether	U.S. Patent No.: 2,267,385 METHOD: Unknown	The residuum is in the form of gummy mass which may contain from 2% (w/w) to 12% (w/w) rotenone
[90]; [94]	Chloroform, benzene	Laboratory research METHOD: Unknown	Not stated
[24]; US-Patent	Methylene chloride and octyl stearate aliphatic acid ester (preferably C <sub>6</sub> to C <sub>30</sub> )	U.S. Patent No.: 4,698,222 and assignee: SAPHYR S. A. R. L (France). METHOD: Accelerated Solvent Extraction (ASE)	The yield of rotenoids resin and rotenone in finely crushed roots of this product are 39% (w/w) and 14% (w/w) respectively
[26]; (Thailand)	Ethanol	Laboratory research. METHOD: Normal Soaking Extraction (NSE) with agitation and soxhlet extraction method	The yield of rotenone in dried roots is 5.20% (w/w) to 8.60% (w/w)

SOURCES	SOLVENT USED	REMARKS	CLAIM
[95]; (Brazil)	Ethanol	Laboratory research. METHOD: Unknown	Not stated
[27, 89]	Acetone	Laboratory research: Temperature (°C): Ambient (26 ± 2 °C) Solvent-to-solid ratio: 10 ml/g Raw material particles size: 0.5 to 2 mm in diameter Extraction time: 24 hrs METHOD: Normal Soaking Extraction (NSE)	The yield of rotenoids resin and rotenone in dried roots are approximately 9% (w/w) and 1.95% (w/w) respectively. Product is identical to the commercial product of SAPHYR S. A. R. L (France) and analytical grade (SIGMA-Aldrich™)

### 5.1 The Use of Biological Assays to Evaluate Botanicals

Bioassays offer a special advantage in the standardization and quality control of heterogeneous botanical products. Products can be 'heterogeneous' due to the presence mixtures of the bio-active compounds either from the same or from purposefully mixed botanical sources [90, 91]. Physical analytical methods such as chromatography are inadequate for this purpose as they are usually insensitive to the chemical complexities found in crude botanicals extract. Most often the desired biological response is due to a mixture of bio-active components and the relative proportions of single bio-active compounds can vary from batch to batch while the biological activity still remains within tolerable limits. Thus, physical or chemical analysis of a single component in such mixtures is not completely satisfactory. Unfortunately, the goal of many phytochemists has been simply to isolate, characterize and publish botanically derived chemical substances without regard to the bioassay. To achieve applied meaning and significance, today's work in natural product chemistry must incorporate bioassay. The extracts must be screened for biological activity whereby the 'active' extracts will be selected and fractionated for further exploitation. This is the salvation of the natural product chemist and such work must be performed with all useful bio-active botanicals if these products are to be accepted and incorporated into legitimate, long term and health practices. Three readily available technologies must be combined are:

1. Separation techniques (Vacuum Liquid Chromatography).
2. Structural elucidation methods (Spectrophotometers and X-ray crystallography).
3. Simple bioassays.

Nowadays natural product chemists are very familiar with the first two but generally they ignore the third. Standardization of the products by biological assays will then generate reproducible benefits and increase consumer confidence. In

addition, in such specific bioassays, the same extracts have to be analyzed many times over and over again before detecting activities. It would seem more logical to pre-screen with general bioassays, throw out the negatives and employ specific bioassays on the activities. The four pre-screening bioassays that useful are:

1. Brine shrimp lethality: A rapid general bioassay for bio-active compounds.
2. Crown gall tumours on potato disc: An animal sparing bioassay for anti-tumour compounds.
3. Frond inhibition of *Lemna* (duckweed): A bioassay for plant growth stimulants inhibitors.
4. Yellow fever mosquito (YFM) Test: A bioassay for pesticides.

### 5.2 Dose-response Curves

The major purpose for performing the biological assay is to establish a cause effect relationship between exposure to a toxic substance and an observed effect in order to determine a safe exposure limit [96]. In general, as the dose increases, so does the number of individually in each group demonstrating the measure response. By plotting this information on a graph, with the horizontal axis representing the increasing of doses and vertical axis representing the increasing of response, a curve can be drawn in which illustrate the relationship between the dose administered and the observed response [97]. This curve is referred to as a dose-response curve as shown in Figure 7.

A dose-response curve can be developed for most phytochemicals and chemicals. From these curves the thresh-old level and the relative toxicity of chemicals can be obtained to help establish safe levels of phytochemicals and chemical exposure [98]. A threshold is a dose below which no effect is detected or above which an effect is first observed. The threshold information is useful in extrapolating animal data to humans and calculating what may be considered a safe human dose for a given substance.

The threshold dose (ThD<sub>0.0</sub>) is measured as mg/kg/day. It is assumed that humans are as

sensitive as the test animal used. To determine the equivalent dose in man, the  $ThD_{0.0}$  is multiplied by an average weight of a man, which is considered to be 70 kg. The calculation used to determine the safe human dose (SHD) is as follows:

$$SHD = ThD_{0.0} \times 70.0 \text{ kg/SF} = \text{Amount mg/day of toxic substance}$$

Where;

SHD: Safe Human Dose.

$ThD_{0.0}$ : Threshold Dose at which no effect is observed.

70 kg: Average weight of a man.

SF: Safety factor (ranges from 10 to 1,000), which varies according to type of test and data used to obtain the  $ThD_{0.0}$ .

The safety factor chosen is dependent on the slope of the dose-response curve, type of experimental animal used, and the availability of data from human exposure. In general, the lower  $LD_{50}$  or  $LC_{50}$ , the larger the safety factor used. The lower  $LD_{50}$  or  $LC_{50}$  implies a more toxic substance, and a higher safety factor is chosen to ensure that a safe human dose established. For example, presume the  $ThD_{0.0}$  for substance A has the  $LD_{50}$  of 0.5 mg/kg and the  $ThD_{0.0}$  for substance B has the  $LD_{50}$  of 5 mg/kg. If all other test protocols are the same, substance A is 10

times more toxic than substance B. Therefore, to determine a safe human dose the safety factor chosen for substance A will be larger (100 or 1000) than the safety factor chosen for substance B, which may be 10. Performing the calculations using these data will result in a safe human dose for substance A being smaller than for substance B.

$$SHD_A = 0.5 \text{ mg/kg} \times 70.0 \text{ kg}/100 = 0.35 \text{ mg/day of toxic substance A.}$$

$$SHD_B = 5.0 \text{ mg/kg} \times 70.0 \text{ kg}/10 = 35.0 \text{ mg/day of toxic substance B.}$$

### 5.3 Hazard Indicator Categories

The Environmental Protection Agency (EPA) has established four toxicity categories based on the  $LD_{50}$  or  $LC_{50}$  as well as an eye and skin effects of the various pesticides. The user is the key to these toxicity categories wherein there is a signal word present on the front panel of the pesticide label. Table 9 summarizes these toxicity categories. Toxicity is usually expressed as the acute oral  $LD_{50}$ . Acute oral refers to a single dose taken by mouth or ingested. Acute dermal refers to a single dose applied directly to the skin (skin absorption). Inhalation refers to exposure through breathing or inhaling.

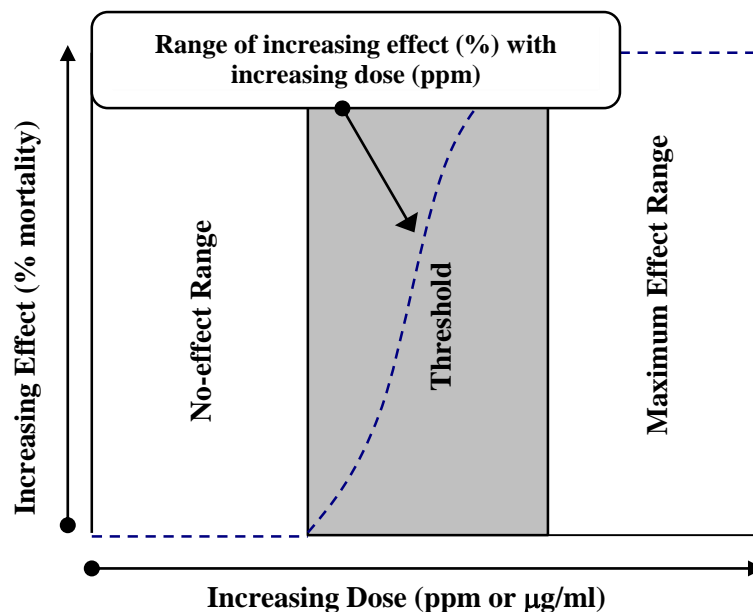

Figure 7 Dose-response curve [96]

Table 9 Hazard indicator categories [104]

< Most toxic/hazardous		> Least toxic/hazardous	
I	II	III	IV
<b>Oral</b> <sup>a</sup> LD <sub>50</sub> : 0 to 50 <sup>b</sup> mg/kg	50 to 500 mg/kg	500 to 5,000 mg/kg	> 5,000 mg/kg
<b>Inhalation</b> <sup>c</sup> LC <sub>50</sub> : 0 to 0.02 <sup>d</sup> mg/L	0.2 to 2 mg/l	2.0 to 20 mg/l	> 20 mg/l
<b>Dermal (skin)</b> <sup>a</sup> LD <sub>50</sub> : 0 to 200 mg/kg	200 to 2,000 mg/kg	2,000 to 20,000 mg/kg	> 20,000 mg/kg
<b>Eye effects:</b> Corrosive - corneal opacity not reversible within 7 days	Corneal opacity reversible within 7 days. Irritation	No corneal opacity. Irritation reversible within 7 days	No irritation
<b>Skin effects:</b> Corrosive	Severe irritation at 72 hrs	Moderate irritation 72 hrs	Mild or slight irritation at 72 hrs
<b>Signal words -</b> <b>DANGER/POISON:</b> In large boldfaced letters on the label and usually accompanied by skull and crossbones symbol	<b>WARNING:</b> In large boldfaced letters	<b>CAUTION:</b> In large boldfaced letters	<b>CAUTION:</b> In large boldfaced letters
<b>Acute (single) oral dosage to human adults:</b> Few drops to 1 teaspoon	1 teaspoon to 2 tablespoons	1 ounce to pint	> 1 pint

<sup>a</sup>LD<sub>50</sub>: Abbreviation for the amount toxicant (poison) needed to kill 50% of a test animal population. It is expressed in terms of weight. LD<sub>50</sub> is used to measure the acute oral and dermal toxicity of a chemical. The lower the LD<sub>50</sub> value, the more poisonous the chemical. LD<sub>50</sub> is not a measure of environmental hazard.

<sup>b</sup>mg/kg: mg of chemical per kg of test animal body weight.

<sup>c</sup>LC<sub>50</sub>: Abbreviation for the amount of toxicant (poison) present in air or water. It is expressed in terms of parts per millions (ppm = mg/l). The lower the LC<sub>50</sub> value, the more poisonous the chemical. LC<sub>50</sub> is not a measure of environmental hazard.

<sup>d</sup>mg/l: mg of chemical per litre of air or water.

## 5.5 Conventional Toxicity Test: Brine Shrimp (*Artemia salina*) Lethality Study

### 5.5.1 *Artemia* Life History

The brine shrimp (*Artemia salina*) is in the phylum arthropoda, class crustacean and is closely related to zooplankton like copepods and *Daphnia* as shown in Figure 8. *Artemia* life cycle begins by the hatching of dormant cysts which are encased embryos that are metabolically inactive. The cysts can remain dormant for many years as long as they are kept dry [105-107].

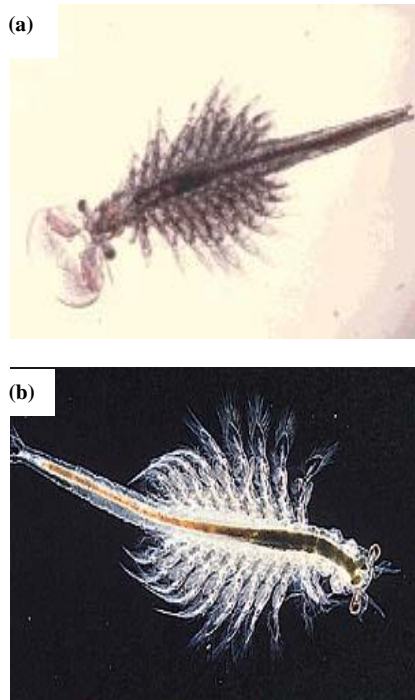

**Figure 8** An adult of *Artemia salina*: (A) male and (B) female [105]

### 5.5.2 Hatching the *Artemia*

When the cysts are placed into salt water, they are re-hydrated and resume their development. After 15 to 20 hrs at 77 °F (25 °C), the cyst bursts and the embryo leaves the shell. For the first few hours, the embryo hangs beneath the cyst shell, still enclosed in a hatching membrane. This is called the umbrella stage. During this stage, the nauplius completes its development and emerges as free swimming nauplii. In the first larval stage, the nauplii are a brownish orange color because of its yolk reserves and do not feed because its mouth and anus are not fully developed. Approximately 12 hrs after hatch they molt into the second larval stage and they start filter feeding on various micro algae, bacteria and detritus [105, 106].

The nauplii will grow and progress through 15 molts before reaching adulthood in about 8 days. Adult *Artemia* average about 8 mm long, but can reach lengths up to 20 mm. An adult is a 20 times increase in length and a 500 times increase in biomass from the nauplii stage. In low salinity and optimal food levels, fertilized females usually

produce free swimming nauplii at a rate of up to 75 nauplii per day [108]. They will produce 10 to 11 broods over an average life cycle of 50 days. Under super ideal conditions, adult *Artemia* can live as long as three months and produce up to 300 nauplii or cysts every 4 days [105, 106].

### 5.5.3 Harvesting the nauplii

Harvest the nauplii by turning off the air or remove the air stone and let the culture settle for about ten minutes. Hatched, empty shells float to the surface, and unhatched cysts will sink to the bottom [105] just above the unhatched cysts on the bottom. Since the newly hatched nauplii are attracted to light (phototropic), by shining a flashlight at the centre of the bottle can concentrate them where it is easy to siphon them off or drain the cysts off the bottom using the valve then drain the nauplii onto another container [105, 107]. The unhatched cysts should be used in the next culture and not thrown away since part of them might be hatch with the next batch.

### 5.5.4 Maintenance of Brine Shrimp

Being a low volume operation, water quality can deteriorate rapidly, especially as biomass increases. The problem usually occurs because of over feeding, which leads to fouling and low oxygen levels. To help overcome this problem, the tank should be taken care seriously. Clean up the bottom every couple of days, turning off the air and let the tank to be settled. Meanwhile siphon the crap off the bottom of the tank and change the salt water about 20% of total volume used per week is adequate enough for their life cycle development [105, 108]. Moderate aeration with coarse or air stones, good water quality and generally clean conditions are all important for raising high densities of adult brine shrimp. Since the *Artemia* feed constantly, faster growth rates and better survival is achieved by multiple or continuous feeding over a 24 hrs period. Usually, *Artemia* are drawn to a strong light. The strong light actually affects their development by slowing down the growth rates. This is due to the increase of their swimming activity and energy expenditure. Therefore, a sufficient light is needed for their normal development. Furthermore, in low light the *Artemia* will spread out in the water column, swimming slowly and achieving more efficient food conservation [106, 107]. A complete Brine Shrimp hatchery system is shown in Figure 9.

### 5.5.5 Optimum *Artemia* Survival Condition

Cyst production is induced by conditions of high salinity and chronic food shortages with high oxygen fluctuations between day and night [107]. Adults can tolerate short exposures to temperatures as extreme as 0 °F to 104 °F (-18 °C to 40 °C). Optimal temperature for cyst hatching and adult grow out is 77 °F to 86 °F (25 °C to 30 °C), but there are differences between other strains. *Artemia* prefer a salinity of 30 ppt to 35 ppt (SG: 1.02 gml<sup>-1</sup>



to 1.03 gml<sup>-1</sup>) and can live in fresh water for about 5 hours before they die [105, 108].

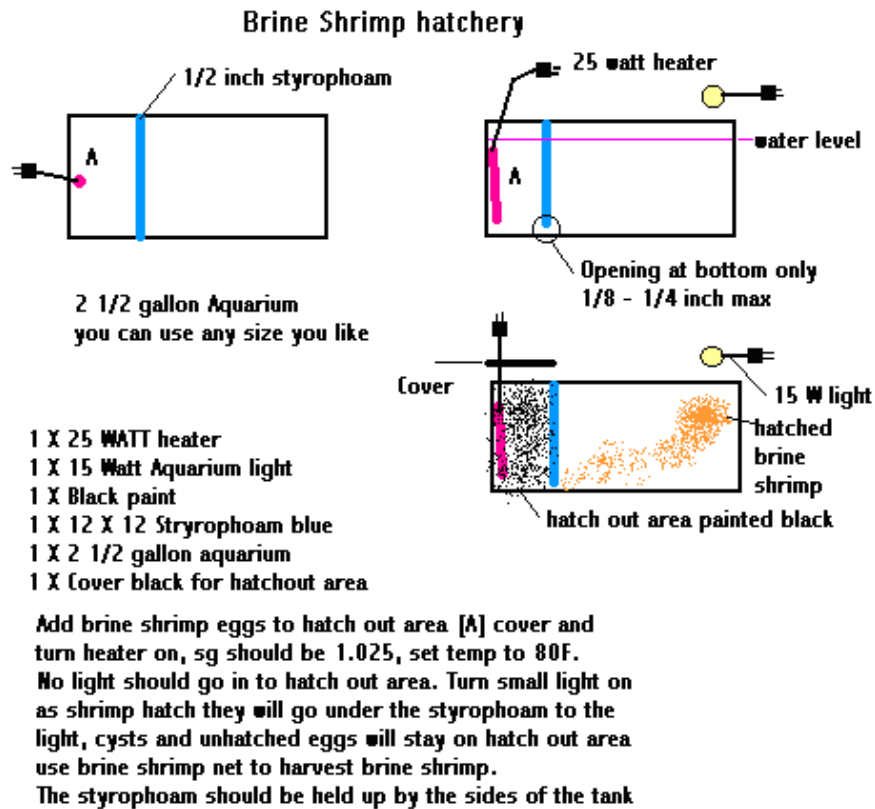

Figure 9 Example of the Brine Shrimp hatchery system [108]

## 6.0 ROTENONE TOXICOLOGY AS PESTICIDES

Rotenone is extremely active as contact and stomach poisons against many crop pest such as Mexican bean beetle, apple and pea aphids, corn borer and household pests [109]. Rotenone is slightly toxic to wildfowl. The LD<sub>50</sub> values for rotenone in mallards and pheasants are greater than 2000 mg/kg and 1680 mg/kg respectively. A dietary LC<sub>50</sub> of 4500 to 7000 ppm is reported in Japanese quail [110]. Since rotenone is used as a fish toxin, it shows that it is very highly toxic to fish. Most of the LC<sub>50</sub> values (96 hours of treatment) for different fish species and daphnids (water fleas) lie in the range of 0.02 mg/l to 0.2 mg/l (ppm). Reported 96 hrs LC<sub>50</sub> were 0.031 mg/L in rainbow trout, 0.0026 mg/l in channel catfish, and 0.023 mg/l in bluegill for the 44% pure formulation [111]. On top of that, the use of rotenone in a large scale eradication of the troublesome carnivorous piranha fish was done in Brazil. It was found that piranha more sensitive than other regional species to the rotenone. Tests showed that

powdered rotenone at the rate of 0.2 ppm, eliminated the piranha (egg, larvae, young and adult) within 20 mins. Therefore, rotenone has a number of advantages as a fish toxicant including low mammalian toxicity at level of use and rapid detoxification in treated waters. Lethal Concentration (LC<sub>50</sub>) is variously reported to be between 0.01 ppm to 0.10 ppm [24]. There is a demand for specific species toxicants to eliminate undesired species while leaving desired fish unaffected. Some success has been achieved using rotenone at levels of concentration and by modes of application that differentiate between species susceptibility and living habits [24]. Aquatic invertebrates have a wide range of sensitivity to rotenone with 48 hrs EC<sub>50</sub> values ranging from 0.002 to 100 mg/l [111]. The compound is not expected to accumulate appreciably in aquatic organisms. The bio-concentration factor for rotenone in the sunfish is 181 times the ambient water concentration. Table 10 show the toxicity data, standard and intakes of rotenone in human and animals.

**Table 10** Toxicity data, standard and intakes in human and animals

Toxicity data	Descriptions
<b>Human data toxicity</b>	
Adults	Mean lethal oral dose is about 0.3 g/kg to 0.5 g/kg [90]. Mammals are not highly susceptible to rotenone because they are protected by effective oxidizing enzyme system [55] and inefficient gastrointestinal absorption [57]
Children	Mean lethal oral dose is estimate from 0.3 g/kg to 0.5 g/kg [90]. In one fatal case, postmortem concentration of rotenone in the stomach and blood were 1,260 ppm and 2.4 ppm [112]
<b>Relevant animal data</b>	The Lethal Dose (LD <sub>50</sub> ) values in milligram per kilogram (mg/kg) of body weight in mammals are ranged from 50 to 300 [113]
Rat (oral)	60 to 132
Rat (intravenous)	0.2 to 0.3
Mouse (intraperitoneal)	5.4
rabbit (oral)	1.5
rabbit (dermal)	100 to 200
rabbit (intravenous)	0.35 to 0.65 [94]
	For rat and dog, experimental inhalation of rotenone dust produced symptoms within minutes. The onset of poisoning is more rapid than after oral administration and the fatal dose is lower [94]. In addition the effect to other organism such as honeybees is nontoxic and harmless. However, it is toxic to bees when used in combination with pyrethrum [114]
<b>Relevant in vitro data</b>	In isolated rat liver mitochondria, the aerobic oxidation of pyruvate is almost completely inhibited by rotenone (Hayes, 1982).
<b>Workplace standards</b>	The TLV-TWA (Threshold Limit Value-Time Weighted Average) for commercial rotenone is 5.0 mg/m <sup>3</sup> . This indicates that an occupational intake of 0.7 mg/kg/day is considered safe (Hayes, 1982)
<b>Acceptable Daily Intake (ADI)</b>	The proposed No-Adverse-Response Level (SNARL) for chronic exposure to rotenone: 0.014 mg/l [115]

### 6.1 Rotenone Mode Of Action

Rotenone is a broad spectrum cytotoxin, as it inhibits the electron transport chain in mitochondria. It is a respiratory enzyme inhibitor, acting between NAD<sup>+</sup> (coenzyme involved in oxidation and reduction in metabolic pathway) and coenzyme Q (a respiratory enzyme responsible for carrying electrons in some electron transport chains), resulting in the failure of respiratory functions [116]. Rotenone inhibits the oxidation of NADH to NAD, blocking the oxidation by NAD of substrates such as glutamate,  $\alpha$ -ketoglutarate, and pyruvate. Rotenone inhibits the mitochondrial respiratory chain between diphosphopyridine nucleotide and flavine. This blockade is overcome by Vitamin K3 (menadione sodium bisulphate), which apparently activates a bypass of the rotenone sensitive site. Rotenone is a powerful inhibitor of mitochondrial electron transport. The regulation of fatty acid synthesis in mitochondria by rotenone may be altered after chronic administration, resulting in fatty changes in the liver [90, 94, 117].

### 6.2 Carcinogenicity, Mutagenicity and Interactions

The carcinogenicity of rotenone is a controversial issue. It has been suggested that rotenone may cause tumour only in vitamin-deficient animals [118]. No mutagenic effects were reported in mouse bone marrow [119]. Rotenone is non-

mutagenic in bacteria reversion tests [120]. When applied in low concentrations to plant foliage, rotenone catalyses photoisomerization of dieldrin and other cyclodiene insecticide residues. However, photodecomposition was a predominant effect when residues of rotenone were combined with those of methylcarbamate and phosphothionate insecticides [121].

## 7.0 CASE STUDY: LABORATORY AND FIELD EFFICACY STUDIES ON THE TOXICITY OF THE FORMULATED ROTENONE

### 7.1 Laboratory Studies (bioassay)

The toxicity of a simple rotenone formulation was evaluated by bioassay in the laboratory against the early 3<sup>rd</sup> instar larvae of the diamondback moth (DBM) by leaf-dipped method. The leaf-dipped method and the larvae of diamondback moth (*Plutella xylostella*) are shown in Figure 10. The diamondback moth (DBM) was collected from Kluang, Johor and Karak, Selangor. The Kluang strain is known for its resistance against some insecticides while the Karak strain is considered as a relatively susceptible strain. Mortality was recorded at 48 and 72 hrs after treatment and data were subjected to the probit analysis to obtain LC<sub>50</sub>.

## 7.2 Field Efficacy Studies

The field trial was conducted in the vegetable farm at University Putra Malaysia (UPM), Selangor, Malaysia from February to April 2004. The treatments were made one month after transplanting the cabbages to the field. The treatments used a simple formulation of rotenone at 30 g A.i/hectare and 15 g A.i/hectare and spinosad as a standard. They were sprayed at 450 L/hectare. Each treatment consisted of 4 replicates. The assessments were made at 3, 7 and 10 days after treatment (DAT) by sampling the number of caterpillars. The experimental design was RCBD (Randomized Complete Block Design). Data collected were subjected to ANOVA and means were compared by LSD. Figure 11 shows the number of larvae of *Spodoptera litura* following the application of chemicals. Figure 11 indicated that rotenone at 30 g A.i/hectare showed better control of the larvae as compared to the control and the performance was comparable to the standard spinosad. The study indicated that a simple laboratory formulation of rotenone was able to provide a good control of the larvae of *Spodoptera litura*. Further field study using the conclusive formulation is ongoing extensively.

**Table 11** Toxicity of the botanical insecticides against the larvae of DBM collected from Kluang, Johor [122]

Insecticide	b ± S.E.	LC <sub>50</sub> (µg/ml)	LC <sub>95</sub> (µg/ml)
Azadirachtin	1.64 ± 0.21	13.31	134.9
Rotenone	2.21 ± 0.27	8.28	46.18
Chlorfenapyr	3.39 ± 0.58	43.39	132.6

**Table 12** Toxicity of the botanical insecticides against the larvae of DBM collected from Karak, Pahang [122]

Insecticide	b ± S.E.	LC <sub>50</sub> (µg/ml)	LC <sub>95</sub> (µg/ml)
Azadirachtin	2.30 ± 0.24	12.11	63.00
Rotenone	4.10 ± 0.43	6.13	15.45
Chlorfenapyr	2.07 ± 0.23	10.37	63.76

In the toxicity study of rotenone against the diamondback moth collected from Kluang and Karak, both strains showed LC<sub>50</sub> of 8.28 and 6.13 µg/ml respectively as shown in Table 11 and Table 12. These values are comparable to the standard compound used against this insect. The study indicated that the diamondback moth (DBM) has yet to develop resistance to rotenone as oppose to chlorfenapyr.

## 8.0 CONCLUSION

In contrast to the demand and increasing need for rotenone as naturally occurring pesticides, the yield of rotenone extracted from Malaysian species are lower than market value. Therefore, the main consideration is to avoid as much possible any thermal degradation that might occurred in the production line. Apart from that, finding the right solvent and processing parameter would increase the availability of rotenone in the crude extracts prior to the formulation of an environmental-friendly based bio-pesticide. Besides that, in order for rotenone to be use as wide range bio-pesticides and substitute to synthetic pesticides, further research and analysis need to be carried especially to determine the side effect of rotenone remnants (traces from vegetables and fruits) against human cells (especially neuron cells) by using an ex-vivo 3-D biomimetic model. This is to confirm its effect on the development of Parkinson diseases at the molecular level. In conclusion, to ensure that that pesticide applications are made in accordance with national and international guidelines several wise approaches are needed for instance ecologically safe plant protection technologies emphasizing the use of botanical insecticides in the integrated pest management (IPM) program, monitoring pesticides residues and established maximum legal admissible levels, known as maximum residue limits (MRLs) so that the quality and quantity of food productions can be improved.

## Acknowledgment

The authors would like to thank the Ministry of Education Malaysia (MOE), Ministry of Science, Technology and Innovation (MOSTI), Universiti Teknologi Malaysia (UTM) and Universiti Kebangsaan Malaysia (UKM) for providing financial support to this project (04-01-06-SF0077, 02-01-06-SF0075, 09-02-06-0083-EA261, FRGS/2/2013/TK04/UKM/03/1 and GGPM-2013-078).

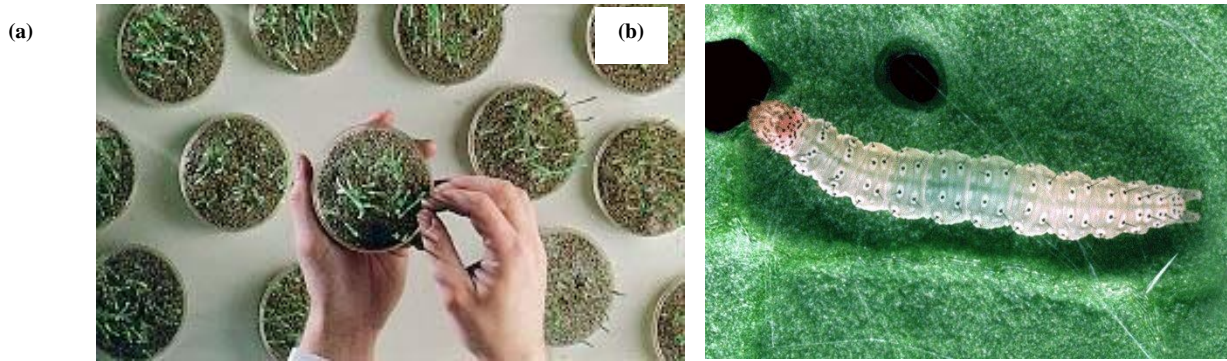

Figure 10 (a) The leaf-dipped method and (b) the larvae of diamondback moth (*Plutella xylostella*) [27]

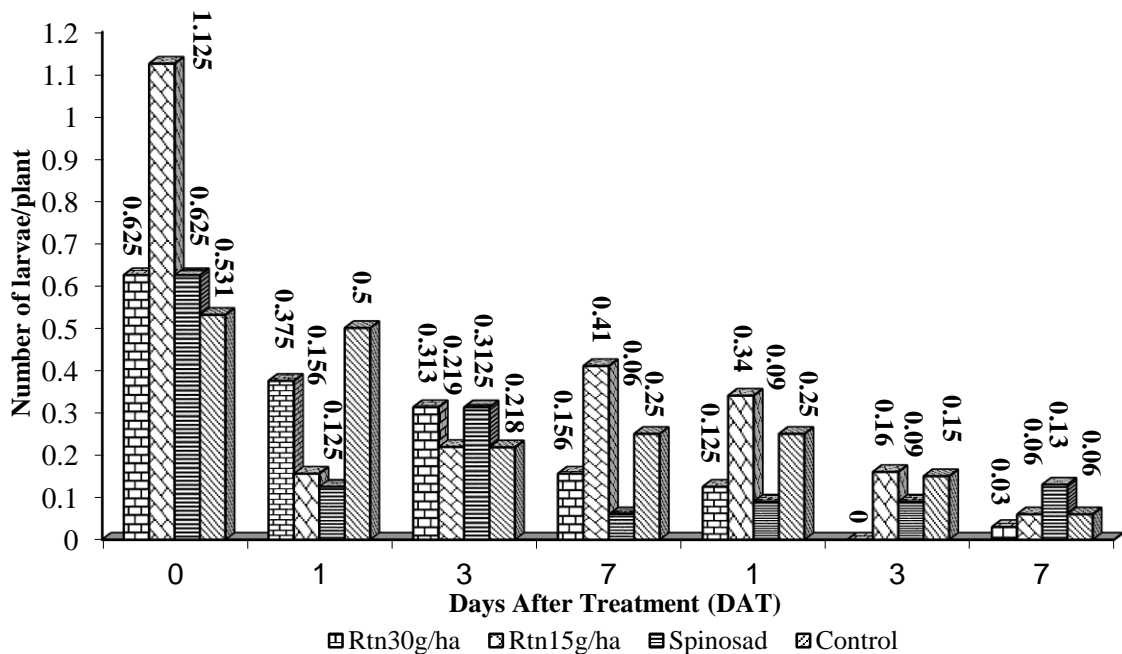

Figure 11 Field efficacy result of the formulated rotenone against *Spodotera litura* [122]

## References

- [1] Population Reference Bureau. 2005. *World Population Datasheet 2005*. Washington. Retrieved January, 10, 2013 from [http://www.prb.org/pdf05/05worlddatasheet\\_eng.pdf](http://www.prb.org/pdf05/05worlddatasheet_eng.pdf).
- [2] Coats, J. R. 1994. Risks From Natural Versus Synthetic Insecticides. *Annual Review of Entomology*. 39(1): 489-515.
- [3] Stoll, G. 1992. Natural Crop Protection in the Tropics-based on Local Farm Resources in the Tropics and Subtropics. Josef Margraf, Weikersheim.
- [4] Stoll, G. 2000. Natural Crop Protection In The Tropics, Letting Information Comes On Life. Agrecol/CTA, Magraf, Weikersheim.
- [5] Copping, L. G. 1998. *The Biopesticide Manual: World Compendium*. British Crop Protection Council.
- [6] Harris, J. and Kennedy, I. 1999. *Pesticides In Perspective*. CAB international.
- [7] WRI. 1996. *World Resources: A Guide to a World Global Environment*. Oxford University Press, NY, USA. 342.
- [8] Devlin, J. F. and Zettel, T. 1999. *Ecoagriculture: Initiatives in Eastern and Southern Africa*. Weaver Press.
- [9] Grainge, M. and Ahmed, S. 1988. *Handbook Of Plants With Pest-Control Properties*. John Wiley & Sons Limited.
- [10] Dev, S. and Koul, O. 1997. *Insecticides Of Natural Origin*. CRC Press.
- [11] Gaby, S. 1986. Natural Crop Protection In The Tropics-DERRIS: *Derris elliptica*, *D. Malaccensis*, *D. uliginosa*. Copyright Margraf Publishers Scientific Books.
- [12] Saxena, M., Saxena, J., Nema, R., Sigh, D., and Gupta, A. 2013. Phytochemistry of Medicinal Plants. *Journal Of Pharmacognosy And Phytochemistry*. 1(6).
- [13] Vermeulen, N. 1998. *Encyclopedia of Herbs*. Whitecap Books.
- [14] Harborne, J. 1998. Methods Of Extraction And Isolation. *Phytochemical Methods*. 3: 60-66.
- [15] Ahmad, F. and Raji, H. 1993. *Kimia Hasil Semula Jadi Dan Tumbuhan Ubatan*. Dewan Bahasa dan Pustaka.
- [16] Vickery, M. L. and Vickery, B. 1981. *Secondary Plant Metabolism*. Macmillan Press.
- [17] Walton, N. J. and Brown, D. E. 1999. *Chemicals From Plants. Perspectives On Plant Secondary Products*. World Scientific.
- [18] Balandrin, M. F., Klocke, J. A., Wurtele, E. S. and Bollinger, W. H. 1985. Natural Plant Chemicals: Sources Of Industrial And Medicinal Materials. *Science*. 228(4704): 1154-1160.
- [19] Lesley, B. 1994. *Herbs*. In: Dorling Kindersley. London. 171-197.

- [20] Yu, S. and Hsu, E. 1985. Induction Of Hydrolases By Allelochemicals And Host Plants In Fall Armyworm (Lepidoptera: Noctuidae) Larvae. *Environmental Entomology*. 14(4): 512-515.
- [21] Dewhurst, I. C. 2001. Toxicological Assessment Of Biological Pesticides. *Toxicology Letters*. 120(1): 67-72.
- [22] Starr, F., Starr, K. and Loope, L. 2003. *Derris elliptica*, United States Geological Survey. Biological Resources Division Haleakala Field Station. Maui, Hawaii.
- [23] Sae-Yuna, A., Ovattlampornb, C., Itharac, A., Wiwattanapatapee, R. 2006. Extraction Of Rotenone From *Derris elliptica* and *Derris malaccensis* By Pressurized Liquid Extraction Compared With Maceration. *Journal of Chromatography A*. 1125(2): 172-176.
- [24] Grinda, Gueyne, Françoise and Jean. 1986. USPTO Patent Full-Text AND Image Database, SAPHYR SARL (France)[US Patent: 4,698,222].
- [25] Zubairi, S. I., Sarmidi, M. R. and Aziz, R. A. 2014. A Study Of Rotenone From *Derris* Roots Of Varies Location, Plant Parts And Types Of Solvent Used. *Advances in Environmental Biology*. 8(2): 445-449.
- [26] Visetson, S. and Milne, M. 2001. Effects Of Root Extract From *derris (Derris elliptica Benth)* On Mortality And Detoxification Enzyme Levels In The Diamondback Moth Larvae (*Plutella xylostella* Linn.). *Kasetsart J.(Nat. Sci.)*. 35: 157-163.
- [27] Zubairi S. I. 2006. The Yield And Biological Activity (LC<sub>50</sub>) Of Rotenone Extracted From *Derris elliptica*. Master of Engineering (Bioprocess) Thesis. UTM Skudai, Malaysia.
- [28] MacKenzie, D. 1993. *Disease Could Wipe Out Baltic Salmon*. New Scientist (United Kingdom),
- [29] Bashan, N., Burdett, E., Guma, A., Sargeant, R., Tumiat, L., Liu, Z. and Klip, A. 1993. Mechanisms Of Adaptation Of Glucose Transporters To Changes In The Oxidative Chain Of Muscle And Fat Cells. *American Journal of Physiology-Cell Physiology*. 264(2): C430-C440.
- [30] Isenberg, J. S. and Klaunig, J. E. 2000. Role Of The Mitochondrial Membrane Permeability Transition (MPT) In Rotenone-Induced Apoptosis In Liver Cells. *Toxicological Sciences*. 53(2): 340-351.
- [31] Betarbet, R., Sherer, T. B., MacKenzie, G., Garcia-Osuna, M., Panov, A. V. and Greenamyre, J. T. 2000. *Nature Neuroscience*. 3(12): 1301-1306.
- [32] Smith, R. A. and Barry, J. W. 1998. Environmental Persistence Of *Bacillus thuringiensis* Spores Following Aerial Application. *Journal of Invertebrate Pathology*. 71(3): 263-267.
- [33] MacKenzie, D. 1999. *Red Flag For Green Spray-Even Organic Farming Is Not Immune To Health Scares*. New Scientist Publ Expediting INC 200 Meacham Ave, Elmont, NY 11003 USA.
- [34] Tayabali, A. F. and Seligy, V. L. 2000. Human Cell Exposure Assays Of *Bacillus Thuringiensis* Commercial Insecticides: Production Of *Bacillus cereus*-like Cytolytic Effects From Outgrowth Of Spores. *Environmental Health Perspectives*. 108(10): 919.
- [35] Dorman, D. and Beasley, V. 1991. Neurotoxicology Of Pyrethrin And The Pyrethroid Insecticides. *Veterinary And Human Toxicology*. 33(3): 238-243.
- [36] Nakamura, Y., Tonogai, Y., Tsumura, Y. and Ito, Y. 1992. Determination Of Pyrethroid Residues In Vegetables, Fruits, Grains, Beans, And Green Tea Leaves: Applications To Pyrethroid Residue Monitoring Studies. *Journal of Aoac International*. 76(6): 1348-1361.
- [37] Trewavas, A. 2001. Urban Myths Of Organic Farming. *Nature*. 410(6827): 409-410.
- [38] Connett, E. and Connett, P. 2001. Fluoride: The Hidden Poison In The National Organic Standards. *Pesticides and You*. 21: 18-22.
- [39] Hien, P. P., Gortnizka, H. and Kraemer, R. 2003. Rotenone-potential And Prospect For Sustainable Agriculture. *Omonrice*. 11: 83-92.
- [40] Hao, N. C. and Hien, P. P. 1998. Technology To Produce The Preparations From The 'Tuba' Roots (*Derris elliptica Benth*). *Proceedings Of Scientific Works For 5 Years 1993-1998* Institute of Tropical Biology ITB, National Center for Natural Sciences and Technology of Vietnam- NCST, HCM Publishing GHouse of Agriculture. 274-281.
- [41] Hein, P. P., Luat, N. V. and Hao, N. C. 1996. Researches On The Growing Conditions And Effect Of Using Rotenone From *Derris elliptica Benth* in Mekong River Delta. *Journal of Science, Technology and Economic Management, Agriculture and Food Industry*. 522-524.
- [42] Hein, P. P., Hao, N. C., Tri, M. D. and Giang, N. C. T. H. 2000. *Vietnamese Journal of Science and Technology XXXVIII*. (3): 116-127 .
- [43] Hien, P. P., Luat, N. V. and Hao, N.C. 1999. Rotenone Bioactivator Controlling Vegetable Insect Pests And Predatory Fish, Monthly. *Journal of Science, Technology and Economic Management, Agriculture and Food Industry*. 1(99): 35-37.
- [44] Kole, R. K., Satpathi, C., Chowdhuri, A., Ghosh, M. R. and Adityachaudhury, N. 1992. Isolation Of Amorphalene, A Potent Rotenoid Insecticide From *Tephrosia Candida*. *J. Agri. Food Chem*. 40(7): 1208-1210.
- [45] Matsumura, F. 1985. *Toxicology Of Insecticides*. Plenum Press New York.
- [46] John, R. A. and Ron, R. K. 1994. Insect Control. *Journal Econ. Ento*. 37: 400-408.
- [47] Andel, T. V., 2000. The Diverse Uses of Fish-Poison Plants in Northwest Guyana. *Economic Botan*. 54(4): 500-512.
- [48] Acevedo-Rodríguez, P., Prance, G. T. and Balick, M. J. 1990. The Occurrence Of Piscicides And Stupefactants In The Plant Kingdom. *New York Botanical Garden*. (8): 1-23.
- [49] Hamid, A. 1999. *Derris Lour. Plant Resources of South-East Asia*. 12(1): 234-242.
- [50] Zubairi, S. I., Sarmidi, M. R. and Aziz, R. A. 2014. Precipitation Of Rotenoids Resin Extracted From *Derris Elliptica* Roots By Means Of Clarifying Agents. *Advances in Environmental Biology*. 8 (2): 441-444.
- [51] Zubairi, S. I., Sarmidi, M. R. and Aziz, R. A. 2014. Bio-Active Constituents of Rotenoids Resin Extracted from *Derris elliptica* Roots: Comparison between Local Plant Extract and SAPHYR (France) Cube Resin. *Advances in Environmental Biology*. 8(4): 904-909.
- [52] Zubairi, S. I., Sarmidi, M. R. and Aziz, R. A. 2014. Identification Of Bio-Active Constituents From *Derris Elliptica* Liquid Crude Extract Using Liquid Chromatographic Method Coupled With High Vacuum Pressure. *Advances in Environmental Biology*. 8(2): 437-440.
- [53] Kaouadji, M., Agban, A., Mariotte, A.-M. and Tissut, M. 1986. Lonchocarpene, A Stilbene, And Lonchocarpusone, An Isoflavone: Two New Pyranopolypheols From *Lonchocarpus Nicou* Roots. *Journal of Natural Products*. 49(2): 281-285.
- [54] Kidd, H., James, D. R., Perkow, W. 1991. *The Agrochemicals Handbook*. Royal Soc. Chemistry Info. Serv., Cambridge, UK. (199).
- [55] Schnick, R. A. 1974. *A Review Of Literature On The Use Of Rotenone In Fisheries*. United States Department of the Interior, Fish and Wildlife Service, Wisconsin.
- [56] Wu, X., Song, Z., Xu, H., Zhang, H., Chen, W., Liu, H. 2012. Chemical Constituents Of The Aerial Part Of *Derris elliptica*. *Fitoterapia*. 83(4): 732-6.
- [57] Bradbury, A. 1986. *Rotenone and Trout stocking n.p*. Washington Department Of Game Fisheries Management Division.
- [58] Smith, M. 1941. Treatment of Potter's Lake, New Brunswick, with rotenone. *Transactions of the American Fisheries Society*. 70(1): 347-355.
- [59] Leonard, J. W. 1939. Notes On The Use Of *Derris* As A Fish Poison. *Transactions of the American Fisheries Society*. 68(1): 269-280.
- [60] Zubairi, S. I., Sarmidi, M. R. and Aziz, R. A. 2015. A Thermal Degradation (Thermolysis) Study of Rotenone Extracted from *Derris elliptica* Roots Using Reverse-Phase High Performance Liquid Chromatography (RP-HPLC). *Sains Malaysiana*. 44(1): 121-126.
- [61] Dawson, V., Gingerich, W., Davis, R. and Gilderhus, P. 1991. Rotenone Persistence In Freshwater Ponds: Effects Of Temperature And Sediment Adsorption. *North American Journal of Fisheries Management*. 11(2): 226-231.

- [62] Cheng, H.-M., Yamamoto, I. and Casida, J. E. 1972. Rotenone Photodecomposition. *Journal of Agricultural and Food Chemistry*. 20(4): 850-856.
- [63] Augustijn-Beckers, P., Hornsby, A. and Wauchope, R. 1994. *The SCS/ARS/CES Pesticide Properties Database For Environmental Decision-Making. II. Additional Compounds*, In *Reviews Of Environmental Contamination And Toxicology*. Springer. 1-82, 2-52.
- [64] Zubairi, S. I., Suradi, H., Mutalib, S. A. A., Othman, Z. S., Bustaman, N. and Musa, W. R. M. W. 2014. Kajian Awalan Terhadap Kinetik Pengekstrakan Pepejal-Cecair dan Analisis Komponen Bio-Aktif Bagi Daun *Hibiscus rosa sinensis*. *Malaysian Journal of Analytical Sciences*. 18(1): 43-57.
- [65] Rice, E. L. 1995. *Biological Control Of Weeds And Plant Diseases: Advances In Applied Allelopathy*. University of Oklahoma Press.
- [66] Vinatoru, M. 2001. An Overview Of The Ultrasonically Assisted Extraction Of Bioactive Principles From Herbs. *Ultrasonics Sonochemistry*. 8(3): 303-313.
- [67] Pinelo, M., Sineiro, J. and Núñez, M. J. 2006. Mass Transfer During Continuous Solid-Liquid Extraction Of Antioxidants From Grape By Products. *Journal of Food Engineering*. 77(1): 57-63.
- [68] Harborne, J. 1984. *Phytochemical Methods*. Chapman and Hall, New York. 3: 100-117.
- [69] Houghton, P. and Raman, A. 1998. *Laboratory Handbook For The Fractionation Of Natural Extracts*. Chapman and Hall, London.
- [70] Smith, R. M. 1999. Supercritical Fluids In Separation Science-The Dreams, The Reality And The Future. *Journal of Chromatography A*. 856(1): 83-115.
- [71] Lang, Q. and Wai, C. M. 2001. Supercritical Fluid Extraction In Herbal And Natural Product Studies-A Practical Review. *Talanta*. 53(4): 771-782.
- [72] Catchpole, O., Perry, N., Da Silva, B., Grey, J. and Smallfield, B. 2002. Supercritical Extraction Of Herbs I: Saw Palmetto, St John's Wort, Kava Root, And Echinacea. *The Journal Of Supercritical Fluids*. 22(2): 129-138.
- [73] Ollanketo, M., Peltoketo, A., Hartonen, K., Hiltunen, R. and Riekkola, M.-L. 2002. Extraction of Sage (*Salvia officinalis* L.) by Pressurized Hot Water And Conventional Methods: Antioxidant Activity Of The Extracts. *European Food Research and Technology*. 215(2): 158-163.
- [74] Choi, M. P., Chan, K. K., Leung, H. W. and Huie, C. W. 2003. Pressurized Liquid Extraction Of Active Ingredients (Ginsenosides) From Medicinal Plants Using Non-ionic Surfactant Solutions. *Journal of Chromatography A*. 983(1): 153-162.
- [75] Coulson, J. M., Richardson, J. F., Backhurst, J. R. and Harker, J. H. 1991. *Chemical Engineering 2*. 4th Ed.
- [76] Musikas, C., Choppin, G. R. and Rydberg, J. 1992. *Principles and Practices of Solvent Extraction*. Dekker.
- [77] Geankoplis, C. J. 1995. *Principles Of Momentum Transfer And Applications. Transport Process And Unit Operations*. 3rd ed. Singapore: Prentice-Hall. 114-213.
- [78] Bogdanov, M. G., Pekova, D., Hristeva, S., Svinjarov, I. and Kantlehner, W. 2010. New Guanidinium-Based Room Temperature ILS Substituent And Anion Effect On Density And Solubility In Water. *Z. Naturforsch., B: J. Chem.Sci.* 65: 37-48.
- [79] Holbrey J. D. and Seddon K. R. 1999. *Ionic Liquids, Clean Technologies and Environmental Policy*. 223-236.
- [80] Fu, X., Dai, S. and Zhang, Y. 2006. Comparison of Extraction Abilities Between Ionic Liquids and Dichloromethane. *Chinese Journal of Analytical Chemistry*. 34(5): 598-602.
- [81] Guo, Z., Lue, B. M., Thomsen, K., Meyer A. S. and Xu, X. 2007. Predictions Of Flavonoid Solubility In Ionic Liquids By COSMO-RS: Experimental Verification, Structural Elucidation, And Solvation Characterization. *Green Chemistry*. 9(12): 1362-1373.
- [82] Reichardt, C. 2005. Polarity Of Ionic Liquids Determined Empirically By Means Of Solvatochromic Pyridinium N-Phenolate Betaine Dyes. *Green Chemistry*. 7: 339-351.
- [83] Gomez, E., Gonzalez, B., Dominguez, A., Tojo, E. and Tojo, J. 2006. Dynamic Viscosities of a Series of 1-Alkyl-3-methylimidazolium Chloride Ionic Liquids and Their Binary Mixtures with Water at Several Temperatures. *Journal of Chemical and Engineering Data*. 51(2): 696.
- [84] Heintz, A., 2005. Recent Developments In Thermodynamics And Thermophysics Of Non-Aqueous Mixtures Containing Ionic Liquids. A Review. *The Journal of Chemical Thermodynamics*. 37(6): 525-535.
- [85] Othman, Z. S., Hassan, N. H., Yusop, M. R. and Zubairi, S. I. 2015. Development of a New Binary Solvent System Using Ionic Liquids as Additives to Improve Rotenone Extraction Yield from Malaysia *Derris* sp. *Journal of Chemistry*.
- [86] Mellein, B. R., Aki, S. N., Ladewski, R. L. and Brennecke, J. F., 2007. Solvatochromic Studies Of Ionic Liquid/Organic Mixtures. *J Phys Chem B*. 111(1): 8-131.
- [87] Mancini, P. M., Fortunato, G. G., and Vottero, L. R. 2004. Molecular Solvent/Ionic Liquid Binary Mixtures: Designing Solvents Based On The Determination Of Their Microscopic Properties. *Physics and Chemistry of Liquid*. 42(6): 625-632.
- [88] Zubairi, S. I., Sarmidi, M. R. and Aziz, R. A. 2014. The Effects of Raw Material Particles Size, Types of Solvents and Solvent-to-Solid Ratio on the Yield of Rotenone Extracted from *Derris elliptica* Roots. *Sains Malaysiana*. 43(5): 707-713.
- [89] Zubairi, S. I., Sarmidi, M. R. and Aziz, R. A. 2014. A Preliminary Study of Rotenone Exhaustive Extraction Kinetic from *Derris elliptica* Dried Roots Using Normal Soaking Extraction (NSE) Method. *Advances in Environmental Biology*. 8(4): 910-915.
- [90] Gosselin, R. E., Smith, R. P. and Hodge, H. C. 1984. *Clinical Toxicology Of Commercial Products*. Williams & Wilkins.
- [91] Williams, P. L., James, R. C. and Roberts, S. M. 2003. *Principles Of Toxicology: Environmental And Industrial Applications*. John Wiley & Sons.
- [92] Kilgore, L. B. 1939. Selective Extraction of Rotenone by. Google Patents.
- [93] Whitmire, H. E. 1941. Manufacture of insecticides. US Patent 2,267,385.
- [94] Hayes, W. J. 1982. *Pesticides Studied In Man*. Williams & Wilkins.
- [95] Gusmão, D. S., Páscoa, V., Mathias, L., Vieira, I. J. C., Braz-Filho, R. and Lemos, F. J. A. 2002. *Derris* (*Lonchocarpus*) urucu (*Leguminosae*) Extract Modifies The Peritrophic Matrix Structure Of *Aedes aegypti* (*Diptera: Culicidae*). *Memórias do Instituto Oswaldo Cruz*. 97(3): 371-375.
- [96] Ottoboni, M. A. 1991. *Dose Makes The Poison; A Plain-Language Guide To Toxicology*. Van Nostrand Reinhold.
- [97] Lu, F. C. 1985. *Basic Toxicology: Fundamentals, Target Organs, And Risk Assessment*. Hemisphere Washington, DC.
- [98] Levine, R. R. 1973. *Pharmacology: Drug Actions And Reactions*. Little, Brown (Boston).
- [99] Finney, D. J. 1964. *Statistical Methods in Biological Assay*. London: Griffin.
- [100] Finney, D. J. 1971. *Probit Analysis*. 3d Ed. Cambridge University Press.
- [101] Hewlett, P. S. and Plackett, R. L. 1979. *An Introduction To The Interpretation Of Quantal Responses In Biology*. Edward Arnold London.
- [102] Zubairi, S. I., Sarmidi, M. R. and Aziz, R. A. 2014. Biological Activity On The Extract Of *Derris Elliptica*: An Optimization Approach To Investigate The Effect Of Processing Parameters On Mortality of *Artemia Salina* *Advances in Environmental Biology*. 8(10): 918-924.
- [103] Colquhoun, D. 1971. *Lectures On Biostatistics: An Introduction To Statistics With Applications In Biology And Medicine*. David Colquhoun.
- [104] EPA, E.P.A.U. 1996. Classification of Pesticides by Acute Human Health Hazards, in *Farm Chemical Handbook* (1996) and *Crop Protection Reference* (1996).
- [105] Greco, F. M., Fitzpatrick, M. P., Wendy, G., Dierenfeld, E. S. and Thoney, D. A. 2002. Preliminary Evaluation Of Selected Nutrient Composition Of Two Life Stages Of *Artemia Salina* Before And After Feeding An Enriched *Torula* Yeast Product. *Wild Conserv. Soc*: 1-5.
- [106] McLaughlin, J. L. 1991. Crown Gall Tumours On Potato Discs And Brine Shrimp Lethality: Two Simple Bioassays

- For Higher Plant Screening And Fractionation. *Methods in Plant Biochemistry*. 6: 1-32.
- [107] McLaughlin, J. L., Rogers, L. L. and Anderson, J. E. 1998. The Use Of Biological Assays To Evaluate Botanicals. *Drug Information Journal*. 32(2): 513-524.
- [108] Ringold, K. 1999. *How I Successfully Hatch Brine Shrimp?* Retrieved November, 24, 2011 from <http://www.angelfire.com/wa/AquariaWeb/artemia.html>.
- [109] Parmar, B., Walia, S., Opende, K. and Dhaliwal, G. 2001. Prospects And Problems Of Phytochemical Biopesticides. *Phytochemical Biopesticides*. 9: 192-223.
- [110] Hill, E. F. and Camardese, M. B. 1986. Lethal Dietary Toxicities Of Environmental Contaminants And Pesticides To Coturnix. Fish And Wildlife Technical Report.
- [111] Johnson, W. W. and Finley, M. T. 1980. Handbook Of Acute Toxicity Of Chemicals To Fish And Aquatic Invertebrates. Summaries Of Toxicity Tests Conducted At Columbia National Fisheries Research Laboratory, 1965-78. United States Fish and Wildlife Service Resource Publication. 137.
- [112] De Wilde, A. R., Heyndrickx, A. and Carton, D. 1986. A Case Of Fatal Rotenone Poisoning In A Child. *Journal of forensic sciences*. 31(4): 1492-1498.
- [113] Ellenhorn, M. J. and Barceloux, D. G. 1997. Diagnosis And Treatment Of Human Poisoning. *Medical Toxicology*. 609-610.
- [114] Morris, S. and Powell. 2000. Backgrounder: Rotenone and Parkinson's Disease. *Nature Neuroscience*. 3: 1301.
- [115] National, R. C. 1983. *Drinking Water and Health*. Volume 5. The National Academies Press.
- [116] Ware, G. and Whitacre, D. 2004. *The Pesticide Book*. 6th. Meister Media Worldwide, Willoughby, OH: 3-5.
- [117] Goodman, L. S., Goodman and Gilman's. 1990. *The Pharmacological Basis Of Therapeutics*. Pergamon Press New York. 1157.
- [118] Gosálvez, M. 1983. Carcinogenesis With The Insecticide Rotenone. *Life Sciences*. 32(8): 809-816.
- [119] Waters, M. D., Sandhu, S. S., Simmon, V. F., Mortelmans, K. E., Mitchell, A. D., Jorgenson, T. A. Jones, D. C., Valencia, R. and Garrett, N. E. 1982. Study Of Pesticide Genotoxicity. *Genetic Toxicology*. Springer. 275-326.
- [120] Moriya, M., Ohta, T., Watanabe, K., Miyazawa, T., Kato, K. and Shirasu, Y. 1983. Further Mutagenicity Studies On Pesticides In Bacterial Reversion Assay Systems. *Mutation Research/Genetic Toxicology*. 116(3): 185-216.
- [121] Hayes, W. J. and Hayes, W. 1975. *Toxicology Of Pesticides*. Williams & Wilkins Baltimore. 1.
- [122] Dzolkifli, O. 2004. Laboratory And Field Efficacy Studies On The Toxicity Of Rotenone. Proposal of Industrial Grant Scheme (IGS) 2004 (2nd proposal) Ministry of Science, Technology and Innovation (MOSTI). Industrial Collaboration Project with Heritage Biotech (M) Sdn. Bhd and Chemical Engineering Pilot Plant (CEPP), UTM Skudai, Johor.