

MODERN TURBO-ROUNDBABOUTS AND THEIR DESIGNING IN THE CZECH REPUBLIC

Miroslav Patočka*, Martin Smělý

Brno University of Technology, Faculty of Civil Engineering, Czech Republic

Article history

Received

18 June 2015

Received in revised form

16 September 2015

Accepted

20 December 2015

*Corresponding author
patocka.m@fce.vutbr.cz

Graphical abstract

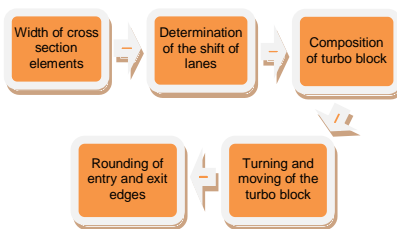

Abstract

Even though the turbo roundabouts have been designed in the Czech Republic since the beginning of this century, until the middle of 2015, there was no national regulation which would describe the way of their construction. As a result of this, there are only 10 turbo roundabouts with various widths of design elements and different traffic signs in the Czech Republic now. From this number there are some that even cannot be considered a turbo roundabout. The aim of this paper is to present the results we gained within the research project and to present readers with the approach to the construction of geometry of turbo roundabouts in the conditions of Czech road network and existing legislation and standards.

Keywords: Turbo-roundabout, raised lane divider, turbo block, overrun area, shift, bias, inscribed diameter, swept path

© 2016 Penerbit UTM Press. All rights reserved

1.0 INTRODUCTION

Roundabouts have been very popular solution for design and reconstruction of at grade intersections in the Czech Republic since the last decade of the 20th Century. Their popularity is mainly due to the following reasons:

- Better safety of traffic thanks to the low speed of passing vehicles and low number of conflict points (32 at 4-way intersection compared to 8 at single lane roundabout)
- Bigger capacity in comparison with normal at grade intersections (2000-2700 veh/h at a roundabout compared to 1500-2000 veh/h at 4-way intersection).

Thanks to these positive features of single lane roundabouts, there was an effort to design a roundabout with even better capacity. This led to building of roundabouts with two and more lanes at circulating carriageway. The results of this arrangement were more or less disappointing because of the unsatisfactory safety and capacity. Bigger inscribed diameters of roundabouts, tangential

connections and building of weaving sections at circulating carriageway led to higher speeds of passing vehicles, which led to higher accident rate and to more serious consequences of the accidents. On the other hand, the increase in capacity was not as big as expected due to the fact that drivers did not want to use the inner lane, because they were afraid of crossing the outer lane, see Figure 1.

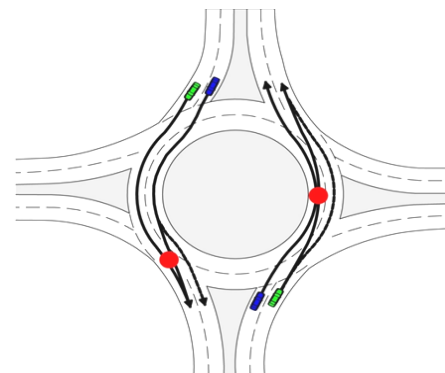

Figure 1 Improper turn conflict at multi lane roundabout

As a response to these shortcomings of multi lane roundabouts, a Dutch traffic engineer L. G. H. Fortuijn developed an alternative arrangement of this type of roundabouts, which is called turbo-roundabout in the Czech Republic.

The philosophy behind turbo-roundabouts is strict channeling of the traffic into different lanes, which a driver has to choose before entering the roundabout according to the desired exit. Vehicles then pass through the roundabout using continuously led, spiral arranged circulating lanes. These lanes are physically separated and this prevents weaving and conflicting of vehicles using the circulating carriageway with vehicles that leave the circulating carriageway [1]. This step lowered the number of conflict points from 16 to 10 and the spatial requirements remained almost the same.

2.0 GEOMETRY OF TURBO-ROUNDABOUTS

Turbo-roundabouts are composed of spirals. These spirals make circular segments (1/2, 1/3 or 1/4 of a circle according to the type of a roundabout) where each arc has bigger radius than the previous one. When the radius of the arc changes, the center of the arc shifts along the translation axis by the corresponding value so that the curve stays connected.

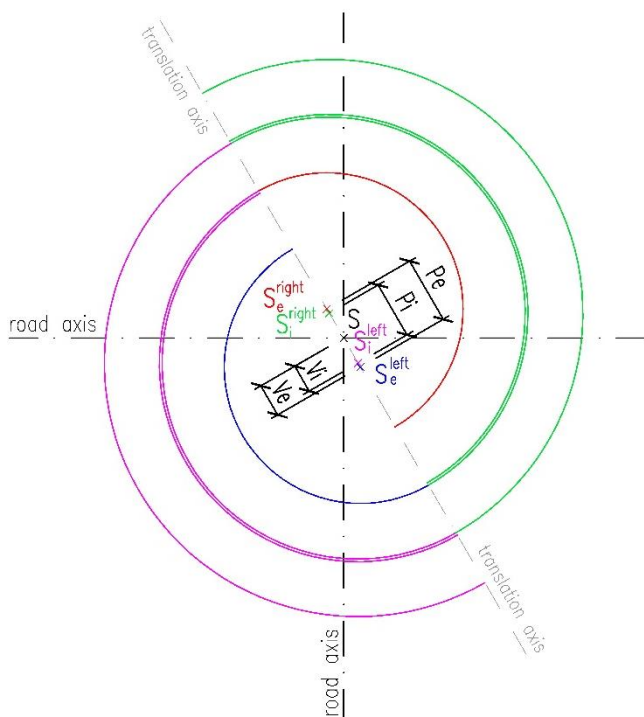

Figure 2 Turbo block

Figure 2 shows turbo block, where is:

S_e^{right} center of the outer arcs right of the translation axis

S_i^{left} center of the inner arcs left of the translation axis

S_e^{right} center of the inner arc right of the translation axis

S_i^{left} center of the inner arc left of the translation axis

P_i shift of inner centers along the translation axis

P_e shift of outer centers along the translation axis

V_i distance from inner center to overall center

V_e distance from outer center to overall center

Idealized geometry of turbo-roundabouts consists of two spirals. Each spiral represents the edge of the roadway. Each spiral consists of three semi-circles with progressively increasing radiuses R_1 , R_2 and R_4 where radii R_2 and R_3 create raised lane divider. The semi-circles meet on the line, which is called translation axis. The arcs on the right side of the translation axis have a center in the point S_e^{right} , which is above the overall center of the turbo-roundabout S . The arcs on the left side of the translation axis have a center in the point S_i^{left} , which is below the overall center of the turbo-roundabout. The distance between those two centers is called a shift along the translation axis. Bias is the distance from its center (S_e^{right} or S_i^{left}) to the overall center S . At the same time, this value equals the half of the shift along the translation axis. In order for the spiral to be continuous the shift along the translation axis must equal the change of the radius [1].

In an ideal case, the shift along the translation axis equals the width of a circulating lane, because the course of the spiral is oriented out from the central island by the width of one lane each 180°. The scheme showing these spirals (see Figure 2) is called turbo block and it constitutes a foundation of geometry for construction of turbo-roundabouts. It is a formation of all arcs of required radii, which need to be arranged in a certain way in order to get the lines of edges of the roadway or circulating lanes. The construction of the turbo block is complicated, because it is necessary to bear in mind that the inner lane needs to be widened in order to secure the negotiability of a turbo-roundabout for the design vehicles and to have enough space for constructing the raised lane divider.

For the purposes of the standardized proposition, four size-categories were introduced (see Table 1). This paper deals only with one specific turbo-roundabout called egg roundabout. The designing process will be demonstrated on an intersection of standard size with inscribed diameter of $D=62.0$ m.

3.0 DESIGNING PROCESS

The designing process of geometry for turbo-roundabout consists of five following steps:

Step 1 – selection of widths of cross section elements – inner radius (radius of the central island), from which the width of inner and outer circulating lane is derived. It is also important to include the width of raised lane divider and guide strips (see Figure 3).

The widths of lanes were taken from the Czech standard ČSN 73 6102 Design of intersections on highways, which specifies widening of lanes in arcs depending on radius of their inner edge. The width of inner lane 6.60 m (measured from inner edges of guide strips) or 7.10 m (measured from the edge of roadway to raised lane divider) is by 1.10 m bigger than the width of the outer lane, because the smaller the radius of the arc, through which the design vehicle must pass, the wider is swept path of the vehicle.

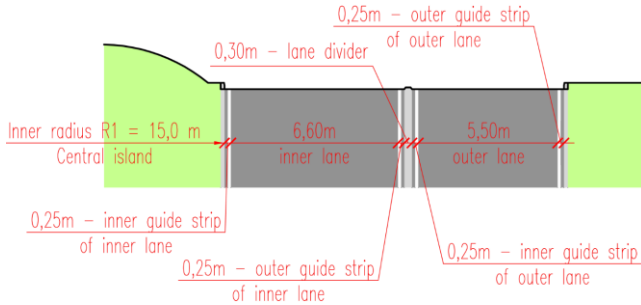

Figure 3 Description of cross section elements

Step 2 - determination of the shift of lanes and following bias for depiction of semicircular arches. The required spiral geometry is complicated by the necessity of including different lane widths and the width of raised lane divider. Instead of one center S_{right} for semicircular arches on the right side of translation axis, two right-sided centers are used. One is slightly more biased than the other. The center with bigger bias $S_{e^{right}}$ is used for inner semicircle ($R1=15.00\text{ m}$) to create transition from inner edge to raised lane divider. The inner center $S_{i^{right}}$ is used for creating the rest of the spirals with radii $R2=21.55\text{ m}$, $R3=21.85\text{ m}$ and $R4=27.85\text{ m}$. Centers $S_{e^{right}}$ a $S_{i^{right}}$ are depicted on the scheme of turbo block, see Figure 2. Likewise, the arches on the left side of the translation axis have two centers $S_{i^{left}}$ a $S_{e^{left}}$, which are in the same distance from the center S like the centers $S_{i^{right}}$ a $S_{e^{right}}$. The shift along the translation axis is evident from the cross section, see Figure 4. The inner edge of the inner lane must be moved out by 7.40 m from the edge of the guide strip towards the raised lane divider. In the same way, it is evident, that the outer edge of the inner lane is moved out by 6.30 m from the raised lane divider towards the outside of turbo-roundabout.

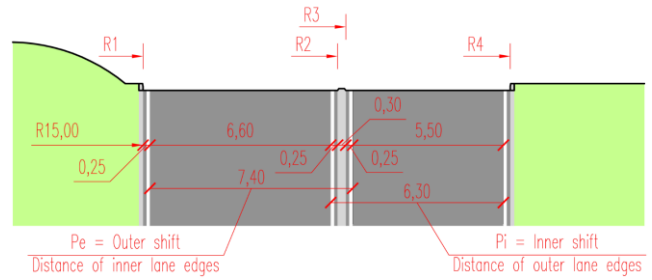

Figure 4 Denotation of radii and shifts

Step 3 - calculating of radius of circular arches and composition of turbo block. At Figure 6 there are arches that represent edges of roadways. Their radii are from $R1$ to $R4$. Formulae for computing follow:

$$R1 = \text{inner radius} \tag{1}$$

$$R2 = R1 + W1 - \Delta \tag{2}$$

$$R3 = R2 + d \tag{3}$$

$$R4 = R3 + W2 \tag{4}$$

where is:

$W1$ width of inner lane

$W2$ width of outer lane

Δ bias difference ($V_e - V_i$)

d width of raised lane divider

The specific values for egg roundabout are in Table 1.

Step 4 - turning and moving of the turbo block so it can be connected to individual legs of the roundabout. Figure 5 shows the correct position of translation axis, assuming that predominant traffic volume is in the direction east - west. The distance between the right edge of roadway of each entry leg and outer arch of inner roadway of circulating carriageway (radius $R2$) should be roughly the same if the translation axis is rotated correctly (the value A is close to value B , see Figure 5).

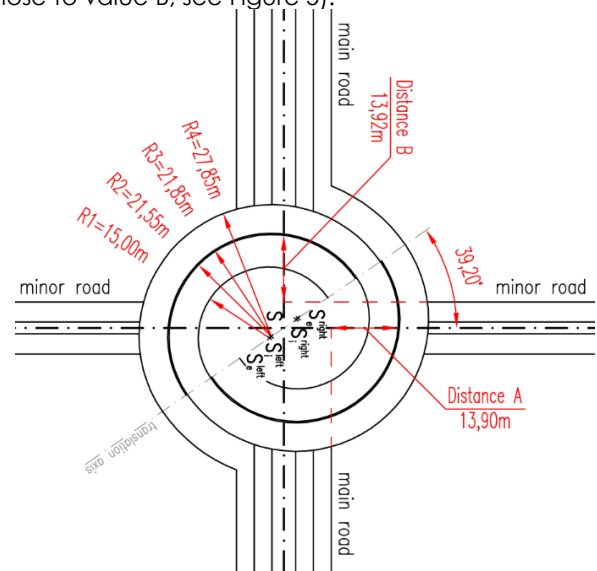

Figure 5 Verification of translation axis position

Step 5 – rounding of entry and exit edges (see Figure 6).

Entry:

- The outer edge of the armpit – simple curve $R=20.0$ m
- The inner edge of the armpit – simple curve $R=12.0$ m

Exit:

- The outer edge of the roadway – compound curve with radii $R1:R2:R3 = 40:20:60$ m

In the area of connection of the legs to the circulating carriageway is appropriate to slightly bias approaching lanes at the entries and exits (around 5° from the axis of leg). This ensures that approaching vehicles lower their speed and facilitates passage of large vehicles and put the entries further from exits. This adjustment has the positive influence on the capacity.

Table 1 Tabulated sizes of design elements for egg roundabout (see also Figure 6)

| Feature of Turbo-roundabout | Symbol | Dimensions | | | |
|---|------------|------------------|------------------|------------------|------------------|
| | | Small | Small standard | Standard | Large |
| Inscribed diameter of Turbo-roundabout [m] | D | < 56.0 | 56.0 – 60.0 | 60.0 – 65.0 | > 65.0 |
| Inside roadway, inner edge [m] | R1 | 10.500 | 12.000 | 15.000 | 20.000 |
| Inside roadway, outer edge [m] | R2 | 17.850 | 18.975 | 21.550 | 25.950 |
| Outside roadway, inner edge [m] | R3 | 18.150 | 19.275 | 21.850 | 26.250 |
| Outside roadway, outer edge [m] | R4 | 24.550 | 25.525 | 27.850 | 31.900 |
| Width of inside roadway [m] | W1 | 8.30 | 7.70 | 7.10 | 6.25 |
| Width of outside roadway [m] | W2 | 6.40 | 6.25 | 6.00 | 5.65 |
| Width of inner lane [m] | α_1 | 7.80 | 7.20 | 6.60 | 5.75 |
| Width of outer lane [m] | α_2 | 5.90 | 5.75 | 5.50 | 5.15 |
| Guide strip [m] | v | 0.25 | 0.25 | 0.25 | 0.25 |
| Lane divider [m] | d | 0.30 | 0.30 | 0.30 | 0.30 |
| Outer shift (distance of outer centers) [m] | Pe | 8.60 | 8.00 | 7.40 | 6.55 |
| Inner shift (distance of inner centers) [m] | Pi | 6.70 | 6.55 | 6.30 | 5.95 |
| Entry radius [m] | Ri | 20.00 | 20.00 | 20.00 | 20.00 |
| Exit radius [m] | Re1 | 40.0; 20.0; 60.0 | 40.0; 20.0; 60.0 | 40.0; 20.0; 60.0 | 40.0; 20.0; 60.0 |
| Exit radius of lane divider [m] | Re2 | 40.0; 20.0; 60.0 | 40.0; 20.0; 60.0 | 40.0; 20.0; 60.0 | 40.0; 20.0; 60.0 |
| Passage speed [2] [km/h] | v_1 | 19-27 | 20-28 | 20-29 | 20-30 |

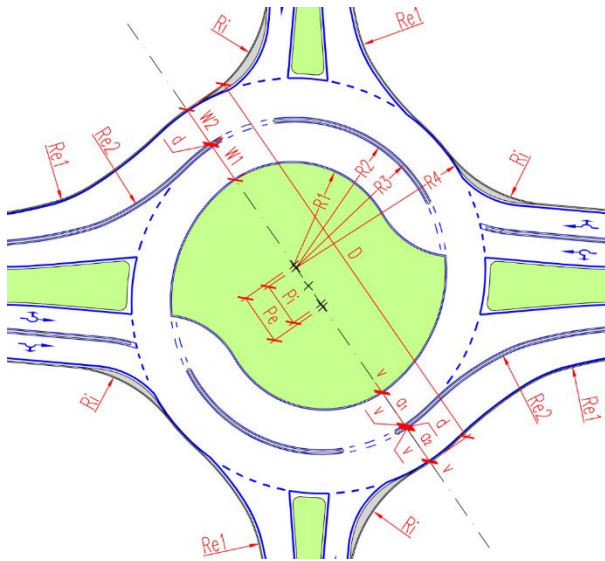

Figure 6 Dimensions stated in Table 1

4.0 CONCLUSION

The proposed width arrangement was in the end checked on different size types of turbo-roundabouts by the largest design vehicles that can be found on Czech road-network (16.5 m long semitrailer and 18.0 m long articulated bus). One of the results can be seen in Figure 7, there is 16.5 m long semitrailer. It is clear from the picture that the design vehicle can pass through the roundabout with enough safe distance from the edges of the roadway. Figure 8 clearly shows that if the circulating lanes are not widened enough, the driver traverses the raised lane divider or the vehicle can even cross to the adjacent lane and the danger of collision can occur.

It is clear from Figure 9 why it is important to use raised lane divider. By using only road marking, drivers tend to shorten their way at the circulating carriageway and cross from one lane to another and this can lead to a collision with another vehicle.

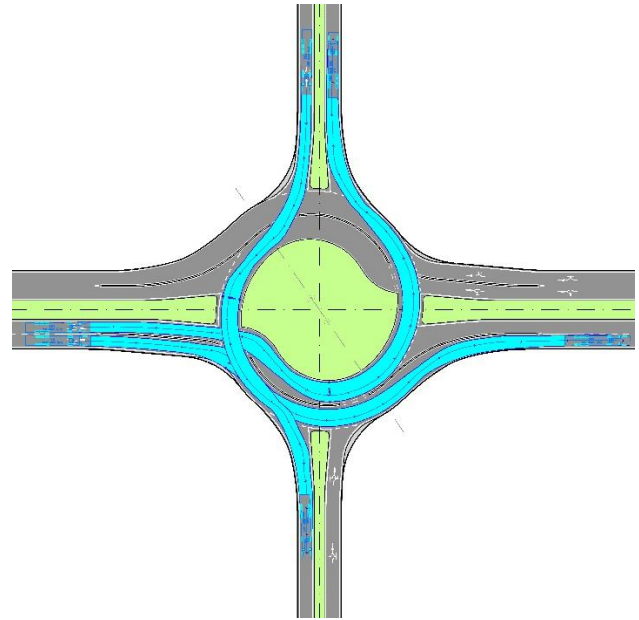

Figure 7 Checking of chosen geometry by swept paths of the design vehicle



Figure 8 Traversing of lane divider by a semitrailer [3]



Figure 9 Incorrect passage through the roundabout with no raised lane divider.

The difference from foreign constructions is that overrun area is not a part of circulating carriageway. There are two reasons for this. Firstly, the deflection of passing trajectory is, considering the inscribed

diameter which was used, so big that there is no need to extend it for passenger cars to maintain their speed. Secondly, there are problems with durability of overrun area, because quite soon, cobblestones are being damaged and this part of roadway is degraded.

Acknowledgement

This paper has been worked out under the project No. LO1408 "AdMaS UP - Advanced Materials, Structures and Technologies", supported by Ministry of

Education, Youth and Sports under the „National Sustainability Programme I”.

References

- [1] OVERKAMP, D. P. a W. VAN DER WIJK. DHV. 2009. Roundabouts - Application And Design: A Practical Manual. Amersfoort. 9.
- [2] CSN 73 6102. 2012. Design of Intersections On Highways. Praha.
- [3] FORTUIJN, L. G. H. 2004. Pedestrian and Bicycle-Friendly Roundabouts; Dilemma of Comfort and Safety. Available from:<http://www.mnt.ee/failid/SlowTrRoundb.pdf>.