

## STUDY ON THE PERFORMANCE OF TWO TOPOLOGY MULTILEVEL INVERTER

N.S.M.Nazar<sup>a</sup>, S. Thanakodi<sup>a</sup>, N.A.Othman<sup>b</sup>, H.D.M.Hidzir<sup>a</sup>, M.S.Mat<sup>a</sup>

<sup>a</sup>Department of Electrical & Electronic Engineering, Faculty of Engineering, Universiti Pertahanan Nasional Malaysia

<sup>b</sup>Institute of High Voltage and High Current, Faculty of Electrical Engineering, Universiti Teknologi Malaysia, 81310, UTM Johor Bahru, Johor

### Article history

Received

7 August 2015

Received in revised form

17 November 2015

Accepted

19 January 2016

\*Corresponding author  
nazatul.shima@upnm.edu.my

### Graphical abstract

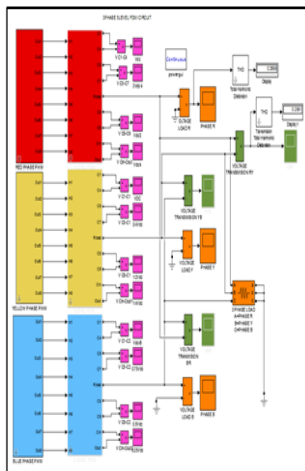

### Abstract

It has been accepted that conventional inverters have limitation dealing with high voltage and high power applications. Lately, multilevel inverters are popular for high power applications due to its improved harmonic profile and increased power ratings. There are various literatures regarding topology and control techniques of multilevel inverters. This paper presents the performance of two Flying Capacitor Multilevel Inverter (FCMI) topologies particularly a 3-level and 5-level multilevel inverters. Besides that, concept of the topologies and its modulation techniques were described. Sinusoidal pulse width modulation (SPWM) techniques were utilized in this paper as the topologies control strategy. Two control parameters, namely the amplitude modulation index,  $m_a$  and the frequency modulation index,  $m_f$  were varied in order to control the output voltage of the inverters. The model and simulation study were carried out using Matlab/Simulink software. Analyses on the performance of the two topologies were based on the fundamental voltage, output voltage waveform, output harmonic spectrum and total harmonic distortion (THD). It's found that the five level FCMI have shown better performance in terms of THD compared to the three level FCMI in all conditions of varied  $m_a$  and  $m_f$ . Based on the study also, five level FCMI shows a better voltage output waveform; close to a sinusoidal waveform compared to the three level FCMI.

Keywords - Flying Capacitor Multilevel Inverter (FCMI), Sinusoidal Pulse Width Modulation (SPWM), multilevel inverter and Total Harmonic Distortion (THD).

© 2016 Penerbit UTM Press. All rights reserved

## 1.0 INTRODUCTION

As the concern over global warming increases, renewable energy source become more significant in term of energy source. It is believed that the power usage of electricity energy can be expanded further by connecting renewable energy sources (RE) to the power system, which may give some new advantages or new threats will appear. Most of the current electricity transmissions utilize alternating current (AC) signal as its transmission and this will be a challenge to integrate renewable energy sources to the grid as it produces direct current (DC).

The term "multilevel inverter" was rooted years ago. Multilevel inverters offer various applications in voltage ranging from medium to high such as in renewable sources, industrial drives, laminator, blowers, fans, and conveyors [1]. Small voltage step result in making the multilevel inverters withstand better voltage, fewer harmonics, high electromagnetic compatibility, reduced switching loss, and better power quality [1].

Several topologies of multilevel inverter were developed to improve the AC output voltage for inverter and reduce stress on the switching components. The preferred multilevel inverters are those able to produce more accurate sine waveform

of AC voltage, low harmonic distortion and consist of fewer components. Some of famous multilevel inverters are diode clamped, cascade multilevel inverter with separate DC source, and flying capacitor [2]. Each type of multilevel inverters has different arrangement of components and voltage source value. Furthermore, each type of multilevel inverter has its own advantages and disadvantages.

Diode clamped inverters were the pioneer multilevel inverters topologies. The main objective of the diode clamped multilevel inverters was introduced to convert DC voltage to AC voltage. Advantages of this topology can be used as a filter to increase the voltages level and resulting in lower harmonic distortion. The topology also was able to yield higher efficiency when operating at the fundamental frequency.

Cascade Multilevel Inverter with Separate DC Source (CISS) is a combination of several single phase full bridge inverters. The function of this multilevel inverter is to generate the output voltage from several DC sources. This is the simplest inverter compared to the other two multilevel inverters. Advantages of this topology are the same numbers of voltage levels at the output terminals can be obtained and cascaded H-bridge inverters require the lowest number of components. Also, the capability of this inverter to soft switching prevents the usage of bulky snubber circuits which also reduces the losses [3-5].

Meanwhile, Flying Capacitor Multilevel Inverter (FCMI) topology is a new method compared to diode-clamped and cascade H-bridge topologies. FCMI was upgraded from diode clamped topology where the diode was replaced with capacitor. It is worth to mention that, the FCMI circuit consists of a lot of capacitors in its development since FCMI need to clamp the device voltage to one capacitor voltage level [6]. The capacity of the voltage increases between two consecutive legs of the clamping capacitors. Hence, to able the sinusoidal output waveform, the output voltage in staircase waveform should be applied by increasing the number of level inverter with accurate switching method [7]. Advantages of this topology are the capabilities to provide buffer during power outages is possible because of the presence of storage capacitors. Also, redundancy in the switching states is available which helps in regulating the capacitor voltages. Thus, the number of the levels of inverter is increased; filters can be used due to low harmonic contents.

This paper presents the performance of two topologies namely 3-level and 5-level multilevel inverter based on the fundamental voltage, output voltage waveform, output harmonic spectrum and total harmonic distortion (THD).

**2.0 METHODOLOGY**

This paper was divided into two parts. The first part is modeling the FCMI inverting circuit up to 5-level while

the second part is modeling 3-level and 5-level FCMI for single phase and three phase using matlab/simulink software.

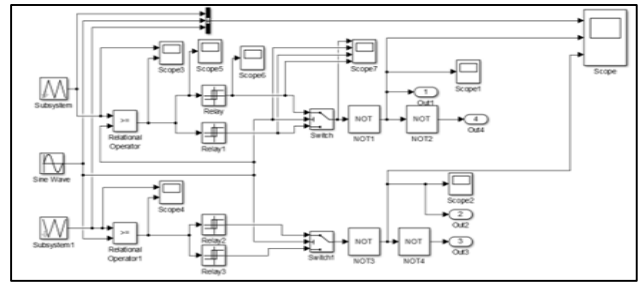

Figure 1 3-Level PWM

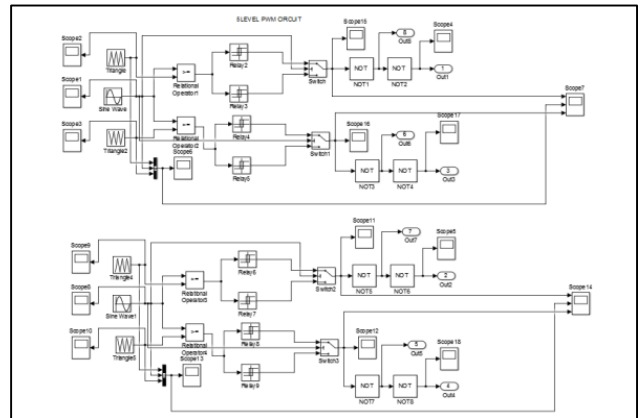

Figure 2 5-Level PWM

Figure 1 and 2 show the 3-level and 5-levels PWM control circuit techniques, respectively. The components used for both PWM are the same but differ in the number of floors. Both levels used the same block for the PWM technique with a phase shift signal at 50Hz frequency. Carrier signal from the signal block is a triangle. This repeating block sequence will generate the signal. Triangle block should be set correctly so that the desired signal can be produced.

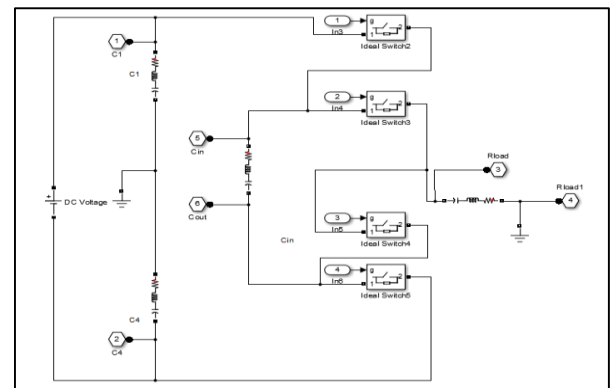

Figure 3 3-Level FCMI Circuit

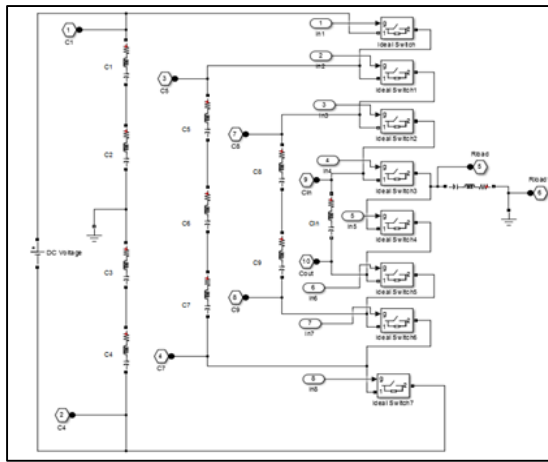

Figure 4 5-Level FCMI Circuit

Figure 3 and 4 shows the development of the 3-Level and 5-Level FCMI circuit, respectively. The numbers of components used are the same but differ in the number of level of the multilevel inverter that will be developed.

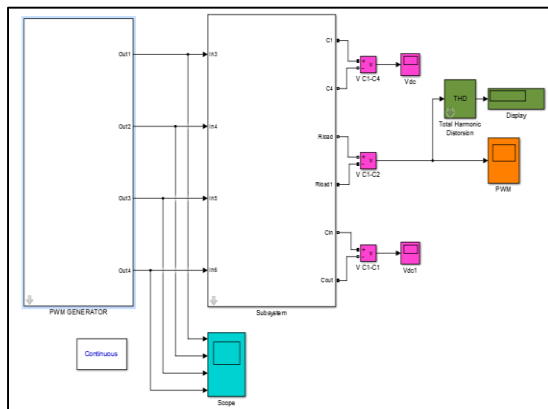

Figure 5 3-Level Single Phases FCMI Circuit

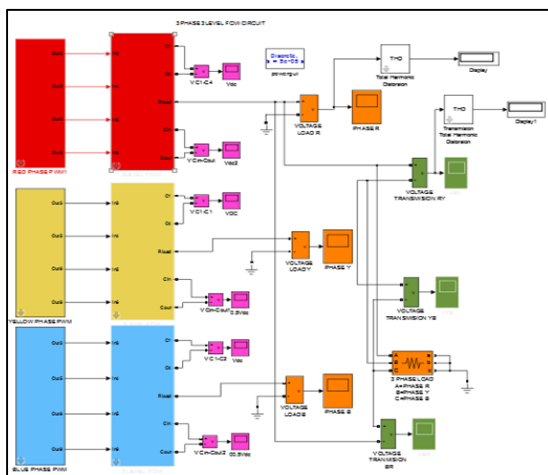

Figure 6 3-Level Three Phase FCMI Circuit

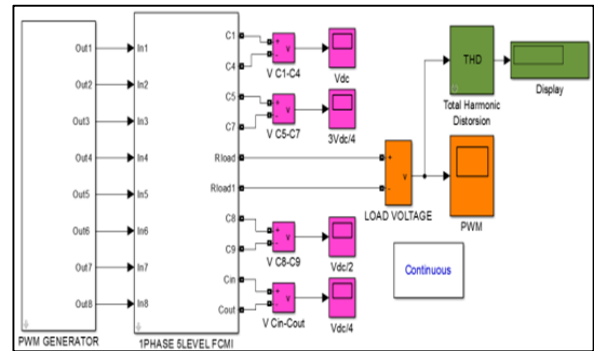

Figure 7 5-Level Single Phases FCMI Circuit

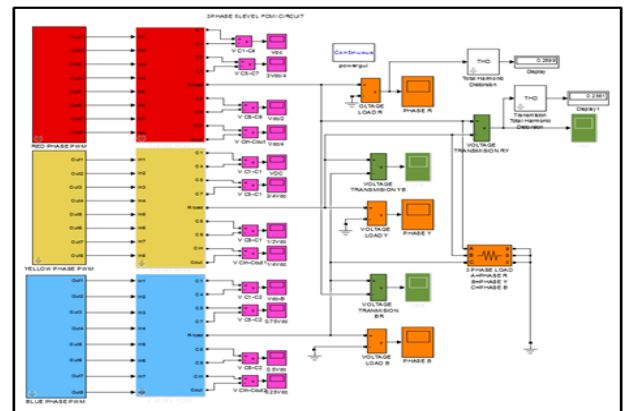

Figure 8 5-Level Three Phase FCMI Circuit

Figure 5 to 8 shows the 3-level and 5-level of single and three phases FCMI circuit used to simulate with the  $m_a$  and  $m_f$  parameter to obtain the desired results for this paper.

### 3.0 RESULTS

Figure 9 shows the voltage waveform of 5-level three phase FCMI. The capability of the 5-level three phase FCMI achieve the maximum level of output voltage shows that three phase circuit is more efficient than single phase circuit where it can synthesis more level of output voltage. More level of output voltages means that the waveform is near to the sinusoidal waveform shape.

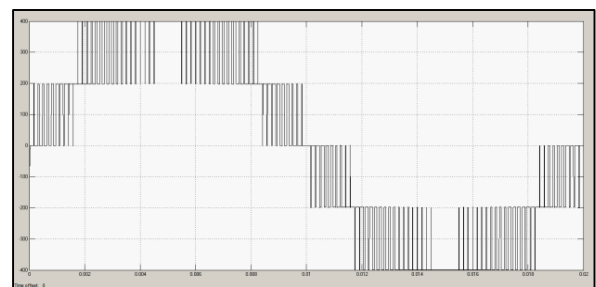

Figure 9 Voltage Waveform 5-Level Three Phase FCMI

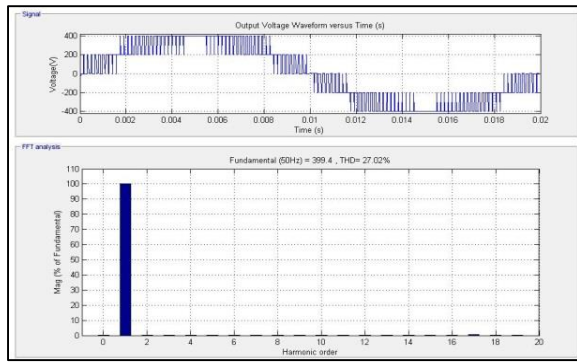

Figure 10 5-Level Three Phase FCMI FFT Analysis

Figure 10 shows the 5-level three phase FCMI FFT analysis. Based on Figure 10 by applying SPWM technique both the even and odd values of  $m_f$  will cause the resulting harmonic spectrum in the same odd order. The presence of harmonics in 5-level FCMI is lower because the harmonic components will eliminate the harmonics in the line voltage.

3level-FCMI			5level-FCMI		
Single phase		Three phase	Single Phase		Three phase
ma	mf	THD	ma	mf	THD
0.2	35	3.424	0.2	35	1.9880
	60	3.420		60	2.5910
0.4	35	2.316	0.4	35	1.2410
	60	2.315		60	1.4050
0.6	35	1.800	0.6	35	0.9814
	60	1.800		60	1.0380
0.8	35	1.477	0.8	35	0.7896
	60	1.477		60	0.8139
1.0	35	1.243	1.0	35	0.6710
	60	1.243		60	0.6968

Figure 11 The Influence of  $m_a$  and  $m_f$  on THD

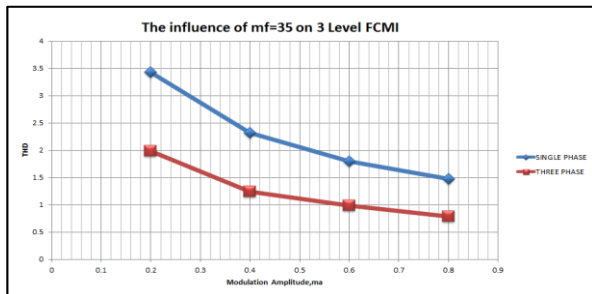

Figure 12 The Influence  $m_f=35$  on 3-Level FCMI

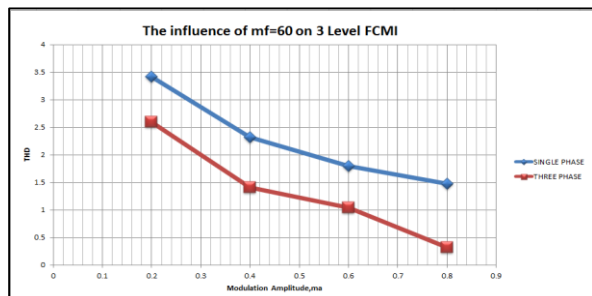

Figure 13 The Influence  $m_f=60$  on 3-Level FCMI

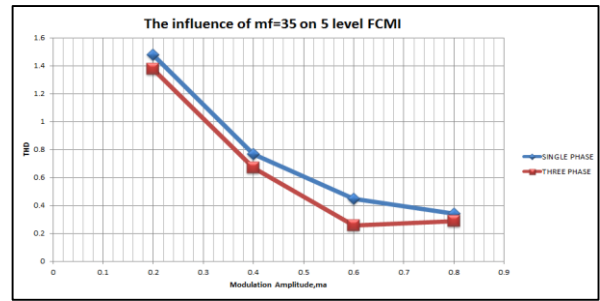

Figure 14 The Influence  $m_f=35$  on 5-Level FCMI

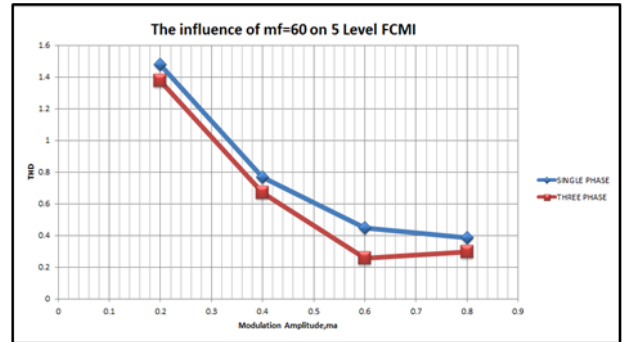

Figure 15 The Influence  $m_f=60$  on 5-Level FCMI

From Table 1, Figure 12 to Figure 15 was obtained to analyze the influence of  $m_f$  with different  $m_f$  value on the 3-level FCMI and 5-level FCMI for single phase and three phases. The  $m_a$  value was set to  $m_a=0.2, 0.4, 0.6, 0.8,$  and  $1.0$ . This result shows the effect of the different  $m_f$  (odd and even value) to the output voltage waveform with the constant value of  $m_a$  that been used.

The fundamental voltages for 3 phase FCMI circuit are higher than the phase voltage. This allows the use of 3 phase FCMI circuit for the high voltage inverter in the industrial applications. Theoretically, the higher value of  $m_a$ , result in lower percentage of distortion factor. This shows that higher value of  $m_a$  represents the increasing of quality at the output voltage waveform. From the simulation analysis, the percentage of distortion factor is decreased as the  $m_a$  value increases.

In conclusion, the selection of  $m_a$  and  $m_f$  is really important in the simulation part to obtain desired results. The optimum output voltage can be generated by using higher value of  $m_a$  and  $m_f$  for PWM switching technique. The 5-level FCMI is much better than the 3-level FCMI in order to obtain lower THD.

#### 4.0 CONCLUSION

This paper presents an overall summary of topology, control technique and multilevel inverter operation especially FCMI. This paper also discussed on SPWM control strategy only for FCMI. It is accepted that the

FCMI 5-level 3 phase circuit is much effective in producing the sinusoidal output voltage compared to the 1 phase FCMI circuit where line voltage can synthesize more voltage levels compared to the load voltage causes the wave approaches the sinusoidal.

In addition, the harmonic spectrum of the 3 phase FCMI circuit is much better than 1 phase FCMI circuit for SPWM switching technique. The FCMI 5-level circuit is much better because less value of THD than the FCMI 3-level circuit. Based on the THD value of output, it can be concluded that as the level of multilevel inverters and the  $m_a$  value increases, lower value of THD can be produced. The lower value of THD indicates the quality of output waveform is near to the desired sinusoidal output. Therefore, the objectives of this study have been achieved. However, this study can be improved and upgraded for future usage.

## References

- [1] Mika, I., Ossi, L. and Marko, K. 2005. Two-level and three-level Converter Comparison in Wind Power Application. Lappeeranta University of Technology, Finland.
- [2] Urmila B. and Subbarayudu, D. 2010. Multilevel Inverter: A Comparative Study of Pulse Width Modulation Techniques. *International Journal of Scientific & Engineering Research*. 1(3): 1-5.
- [3] Rashid, M. H. 2004. Power Electronics: Circuits, devices and applications. Third Edition. Prentice Hall.
- [4] Rodriguez, J., Lai, J.S. and Peng, F.Z. 2002. Multilevel Inverter: A Survey of Topologies, Controls and Applications. *IEEE Transactions on Industrial Electronics*. 49(4): 724-738.
- [5] Panagis Stergiopoulos, P. Marabes, P. and Manias, S. 2008. Comparison of State of the Art Multilevel Inverters. *IEEE Power Electronics Specialists Conference*. 4296-4301.
- [6] Murugesan, G., Jagabar, S.M. and Praveen, M. 2011. A New Multilevel Inverter Topology Using Less Number of Switches. *International Journal of Engineering Science and Technology (IJEST)*. 3(2): 157-160
- [7] Tolbert, L.M., Peng, F.Z., Habetler, T.G. 1999. Novel Multilevel Inverter Carrier-Based PWM Method. *IEEE Transaction on Industry Application*. 35(5): 1-7
- [8] Spring, 2004. Topic 7: Pulse Width Modulation Techniques for Voltage-Fed Inverters. ECE 8830 Electric Drives.
- [9] Crowley, I.F., Leung H.F. and Bitar, S.J. 2011. PWM Techniques: A Pure Sine Wave Inverter. 2010-2011 Worcester Polytechnic Institute Major Qualifying Project.
- [10] Ebadpour, M., Sharifian, M. B. B. and Hosseini, S. H. 2011. A New Structure of Multilevel Inverter with Reduced Number of Switches for Electric Vehicle Applications. *Energy and Power Engineering*.