

EFFECT OF WATER CURRENT ON UNDERWATER GLIDER VELOCITY AND RANGE

Muhammad Yasar Javaid^a, Mark Ovinis^{a*}, Fakhruddin Mohd Hashim^a, Adi Maimun^b, Yasser M. Ahmed^{b,c}, Barkat Ullah^a

^aDepartment of Mechanical Engineering, Universiti Teknologi PETRONAS, Perak, Malaysia

^bMarine Technology Centre, Faculty of Mechanical Engineering, Universiti Teknologi Malaysia, Johor Bahru, Malaysia

^cDepartment of Naval Architecture and Marine Engineering, Faculty of Engineering, Alexandria University, Alexandria, Egypt

Article history

Received

11 December 2015

Received in revised form

19 January 2016

Accepted

16 February 2016

*Corresponding author
mark_ovinis@petronas.com.my

Graphical abstract

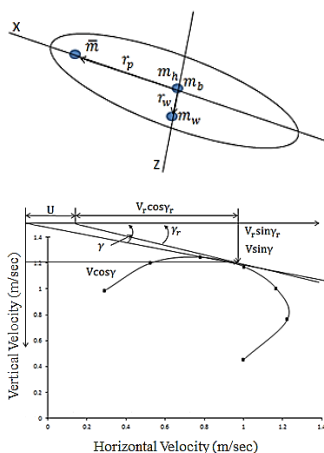

Abstract

An autonomous underwater glider speed and range is influenced by water currents. This is compounded by a weak actuation system for controlling its movement. In this work, the effects of water currents on the speed and range of an underwater glider at steady state glide conditions are investigated. Extensive numerical simulations have been performed to determine the speed and range of a glider with and without water current at different net buoyancies. The results show that the effect of water current on the glider speed and range depends on the current relative motion and direction. In the presence of water current, for a given glide angle, glide speed can be increased by increasing the net buoyancy of the glider.

Keywords: Underwater glider, Dynamic model, Water current, Glider performance

© 2016 Penerbit UTM Press. All rights reserved

1.0 INTRODUCTION

Underwater gliders are attractive because of their low cost, autonomy, and capability. The propulsion of an underwater glider is by means of shifting its center of gravity and changes in its buoyancy. While this method of propulsion is attractive for long-range, extended duration deployments, it is especially susceptible to ocean currents. Furthermore, to achieve maximum endurance, gliders are normally designed for low speeds, which increase their susceptibility to ocean currents. Ocean current varies dramatically with increasing depth [1], and will influence the velocity of the glider and its working range [2]. The magnitude of water current near the

surface of the sea may be significant, which will have an impact on the glide path of weak self-propelled vehicles such as gliders.

Woolsey and Thomasson [3, 4] developed a nonlinear dynamic model of rigid vehicle motion subjected to non-uniform flow. Their findings showed that the glide path is significantly affected, especially when the fluid flow is dense and particularly at low relative speed. Shuangshuang [5] investigated the dynamic motion model that incorporates the internal moving mass and general actuation system of an underwater glider in non-uniform and unsteady flow of water current. These models were based on Lagrangian principle and Lamb theory [6], related to a moving cylinder under the dense and rotational

flow. These models, however, were used to predict the relative flow speed to unmanned vehicles by using adaptive filtering parameter techniques. Graver and Mahmoudian *et al.* [7, 8] derived the dynamic model of a glider including the linear translational motion of an internal moving mass to control the attitude of the glider, without considering the effect of water current. These dynamic models incorporate cylindrical buoyancy control actuation, which is applicable to existing gliders such as the Slocum [9], Spray [10] and Seaglider [11]. Zhang *et al.*, [12] derived the nonlinear dynamic model of a gliding robotic fish based on Newton's Law. This model consists of linear moving mass in steady state condition without any water currents. In this study, Zhang's dynamic model for the translational motion of a glider at steady state condition is extended to include the effect of water current.

This work is organized as follows: In the first section, a brief overview of the dynamic model of the glider, considered as a rigid body point mass subjected to internal and external control input forces, is presented. This model is subjected to currents to investigate the glider performance in terms of range and sink rate. In the second section, the dynamics of the glider i.e. the glide angle, velocity and angle of attack in the presence of water current is investigated. The results are compared to gliders not subjected to water currents.

2.0 METHODOLOGY

2.1 Dynamic Equations Of Motion

The glider is considered as a rigid body point mass (m_G) immersed in a fluid with uniform density. As gliders are by design neutrally buoyant, the glider mass, m_g equals the mass of the displaced fluid, m . In general, if $(m_0 = m_G - m)$ is positive, the glider will tend to sink, while if m_0 becomes negative, the glider will tend to float.

2.2 Kinematics

Let's assume that the position vector of a glider in an inertial frame of reference is $[i_x, j_y, k_z]$ and the position vector of the origin to the body frame of reference is $[b_x, b_y, b_z]$, as shown in Figure 1.

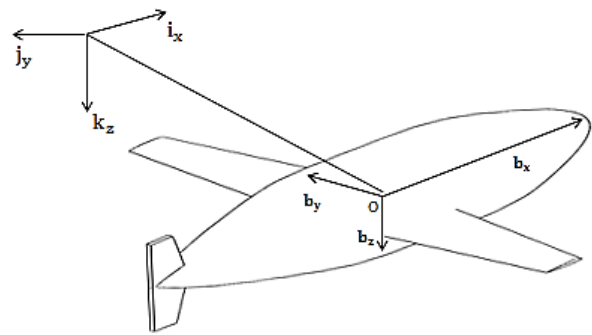

Figure 1 Glider coordinate orientation

The orientation of the glider is then mapped with a rotational matrix, R from the body frame of reference to the inertial frame of reference. Let the linear velocity $v = [v_x, v_y, v_z]^T$ and the angular velocity $\omega = [\omega_x, \omega_y, \omega_z]^T$ in body frame of reference. The corresponding kinematic equations are

$$\dot{R} = R\hat{\omega}_b \tag{1}$$

$$\dot{b} = Rv_b \tag{2}$$

2.3 Dynamic

The glider is considered as a rigid body for the dynamic model, with an internal moving mass to control the motion of the glider. The internal moving mass, \bar{m} , is shown in Figure 2.

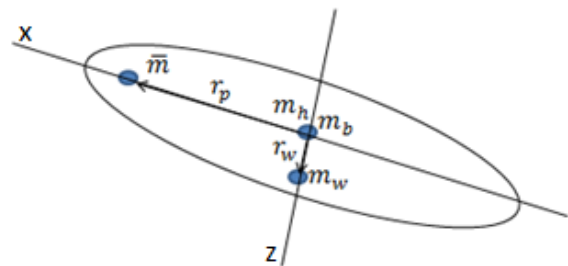

Figure 2 Mass distribution of a glider

The total glider masses can be express as $m_G = m_h + m_w + m_b + \bar{m}$. m_h is total uniform hull mass, m_w is fixed mass to balance the center of gravity and buoyancy with position vector r_w , m_b is ballast mass and \bar{m} is pitch control mass sliding with respect to r_p along the glider nose along the x-axis, as shown in Figure 2. Zhang [13] simplified the dynamic model of underwater glider with external forces based on Newton's Second Law. The

translation of a rigid body is described by applying Newton's laws as

$$F = \frac{dMv_i}{dt} = M \frac{dv_b}{dt} + \omega_b \times Mv_b \quad (3)$$

Here 'M' is totaling mass including glider mass and added mass i.e. $M = m_G I + M_f$ where I is the identity matrix and M_f is the added mass matrix.

Zhang et al. [12] simplified the dynamic model by reducing it to motion along the longitudinal plane, as given in Eq. 3 - 5.

$$\dot{X} = v_x \cos\theta + v_z \sin\theta \quad (4)$$

$$\dot{Z} = -v_x \sin\theta + v_z \cos\theta \quad (5)$$

$$\dot{\theta} = \omega_y \quad (6)$$

$$\dot{v}_x = \frac{1}{m + \bar{m}} \left(-(m + \bar{m})v_z \omega_y - m_0 g \sin\theta + L \sin\alpha - D \cos\alpha \right) \quad (7)$$

$$\dot{v}_z = \frac{1}{m + \bar{m}} \left(-(m + \bar{m})v_x \omega_y - m_0 g \cos\theta - L \cos\alpha - D \sin\alpha \right) \quad (8)$$

$$\dot{\omega}_y = \frac{1}{J_y} \left((M - m_w) g_r \sin\theta - \bar{m} g_r \cos\theta \right) \quad (9)$$

Here, v_x and v_z are the glider velocity along x-axis and z-axis respectively, θ the pitch angle, ω_y the glider angular velocity along the y-axis, $\alpha = \tan^{-1}(v_z/v_x)$ the angle of attack, D and L the drag and lift coefficient of the glider. ' M_{DLy} ' is the moment force along xz-plane, J_y the total inertia force, as shown in Figure 3.

2.4 Point Mass Model

Lanchester [14, 15] derived the dynamic equation of aircraft in the longitudinal plane including the velocity vector and glide angle. These equations are integral-able with simple assumptions as Equations 4-9 are transformed from the body frame (v_x, v_z) to polar inertial coordinates (V, γ) as shown in Equation 10 - 13. The velocity 'V' represents the total velocity vector of the glider with respect to glide angle γ . Leonard and Bhatta [16] used Lanchester's [14, 15] equations for the dynamic modelling of an underwater glider as a Phugoid-mode model and simplified the dynamic behavior to four state variables ($V, \gamma, \alpha, \omega$). These four states are

$$\dot{V} = \frac{1}{m_1} \left(-D - m_0 g \sin\gamma \right) \quad (10)$$

$$\dot{\gamma} = \frac{1}{m_1 V} \left(L - m_0 g \cos\gamma \right) \quad (11)$$

$$\dot{\alpha} = \omega_y - \frac{1}{m_1 V} \left(L - m_0 g \cos\gamma \right) \quad (12)$$

$$\dot{\omega}_y = \frac{M_{DLy}}{J_y} \quad (13)$$

In the dynamic model, the total added mass of the glider along the longitudinal plane is considered as ($m_1 = m_3 = m_1$). m_0 is the net buoyancy, which is positive along the direction of gravity. V & γ are the total velocity vector and glide path respectively. D is the drag force, which is positive in the direction opposite the velocity vector of the glider. L is the lift force perpendicular to the velocity vector of the glider. M_{DLy} and J_y is the moment and the total inertia along the y-axis, as shown in Figure 3.

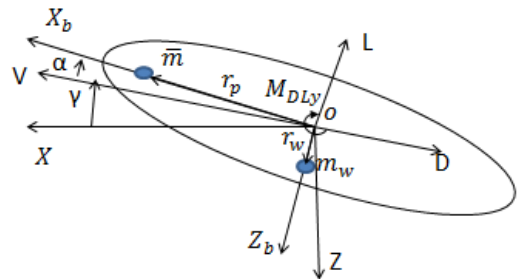

Figure 3 Forces and moments balance

2.5 Point Mass Model with Water Current

The effect of water current on the longitudinal dynamic equations is considered here. First, the velocity of glider relative to the glide angle under the influence of water current, as shown in Figure 4, is determined.

$$\Delta\gamma = \gamma - \gamma_r$$

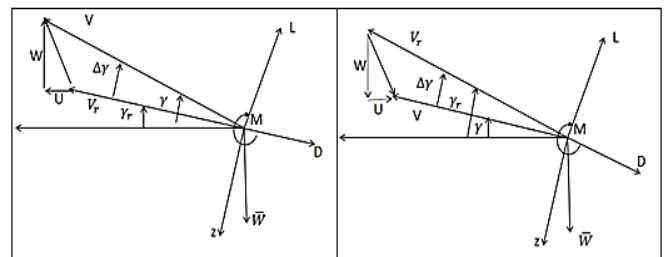

Figure 4 Equilibrium Force Diagram

Next, the horizontal, 'U' and vertical water current 'W' are considered.

$$\dot{X} = V_r \cos \gamma \pm U \quad (14)$$

$$\dot{Z} = V_r \sin \gamma \pm W \quad (15)$$

Where X is the horizontal position, Z is the vertical position and \dot{Z} the glider sink rate. γ is the glide path and V the glider velocity without water current. The corresponding dynamic equations are:

$$\dot{V} = \frac{1}{m_1} (L \sin(\Delta\gamma) - D \cos(\Delta\gamma) - m_0 g \sin \gamma) \quad (16)$$

$$\dot{\gamma} = \frac{1}{m_1 V} (L \cos(\Delta\gamma) + D \sin(\Delta\gamma) - m_0 g \cos \gamma) \quad (17)$$

$$\dot{\alpha} = \omega_y - \frac{1}{m_1 V} (L \cos(\Delta\gamma) + D \sin(\Delta\gamma) - m_0 g \cos \gamma) \quad (18)$$

$$\dot{\omega}_y = \frac{M_{DLy}}{J_y} \quad (19)$$

When there is no water current, $\gamma = \gamma_r$, $\cos(\Delta\gamma) = 1$ and $\sin(\Delta\gamma) = 0$ then the equation 16 and 17 is

$$\dot{V} = \frac{1}{m_1} (-D - m_0 g \sin \gamma), \quad \dot{\gamma} = \frac{1}{m_1 V} (L - m_0 g \cos \gamma)$$

2.6 Hydrodynamic Forces

The hydrodynamic forces of the glider are similar to aircraft aerodynamic forces and moments [17, 18]. However, buoyancy and added mass are significant in the dynamics of underwater gliders due to the high relative density of water (800 times greater than air). Hydrodynamics forces are related to the angle of attack and velocity of the glider as shown in below Equations.

$$D = \frac{1}{2} \rho S V^2 C_d = (K_{D0} + K_D \alpha^2) V^2$$

$$L = \frac{1}{2} \rho S V^2 C_l = (K_{L0} + K_L \alpha) V^2$$

$$M = \frac{1}{2} \rho S V^2 C_m = (K_{M0} + K_M \alpha) V^2$$

Where C_d , C_l and C_m are the drag, lift and moment coefficients respectively 'S' the characteristic area, ' ρ ' density of water. K_{D0} , K_D are drag coefficients, K_{L0} , K_L lift coefficients and K_{M0} , K_M are moments coefficients. These coefficients are usually evaluated using CFD simulation, wind tunnel tests or theoretical parameter identification, or combination of these methods.

3.0 RESULTS AND DISCUSSION

In this study, the glide velocity of newly build autonomous underwater glider for various glide angles was determined based on its hydrodynamic coefficients as shown in Figure 5. In addition, the effect of water current on the glider in steady state conditions at different glide angles and angles of attack were evaluated.

The hydrodynamic forces and moments coefficients of the glider were first determined using ANSYS Fluent [19]. In this work, a rectangular shaped fluid domain is created around the glider, as described in ITTC [20]. The upstream boundary of the fluid domain is $2L_{glider}$ away from the glider body and the downstream location is $6L_{glider}$ from the glider. The width and height of the fluid domain are $10D_{glider}$. The refined unstructured mesh was generated using ANSYS workbench. For numerical simulation, a low Reynolds turbulence model is used to investigate the hydrodynamic coefficients, because the Reynolds number for submerged vehicles vary between 1×10^5 to 1×10^6 [21]. The hydrodynamic coefficients are determined at different angles of attack for a constant fluid speed and fluid domain. Hydrodynamic coefficients are a function of angle of attack; the drag coefficient is a quadratic function of the angle of attack while moment and lift are linear functions of the angle of attack. The hydrodynamic coefficients are shown in Table 1.

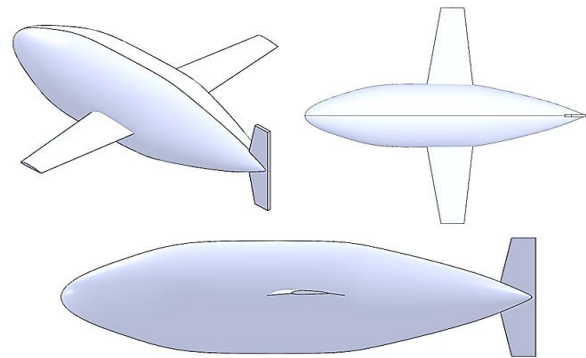

Figure 5 Autonomous Underwater Gliders

Table 1 Lift and Drag coefficients based on CFD simulation

Parameters	Values	Description
K_{D0}	0.3293	Coefficient of drag force
K_D	3.562	
K_{L0}	0.2017	Coefficient of lift force
K_L	6.62	
K_{M0}	0.01575	Coefficient of moment
K_M	2.442	

The steady state dynamic equations of the point mass model are simplified by setting the derivatives equal to zero. The glide angle for maximum range and velocity of glider, without considering any water current, is therefore

$$\gamma_r = \tan^{-1} \left(-\frac{D}{L} \right) \tag{20}$$

$$V_r = \sqrt{\frac{2m_0 g \cos(\gamma_r)}{K_{L0} + K_L \alpha}} \tag{21}$$

The relationship between the optimal angle of attack and glide angle with hydrodynamic coefficients from the Equation 4-6 [7] is

$$\alpha = \frac{1}{2K_D} \left(-K_L \tan(\theta) - \sqrt{(K_L \tan(\theta))^2 - 4K_D(K_D \tan(\theta) + K_{D0})} \right) \tag{22}$$

Figure 6 shows the glider polar plot i.e. glider vertical velocity versus glider horizontal velocity. The glider polar curve shows that the horizontal velocity at equilibrium conditions with the water current (U) influences the glide angle. The equilibrium glide velocity (V_r) has direct function of glide angle (γ_r) which affects the glider operational range and sink rate. The glider sink rate is the function of its vertical velocity, as illustrated in Figure 6. In this study, the horizontal water current speed values considered were between -0.1 m/s to 0.1 m/s.

Figure 7 shows that the sink rate of the glider decreases when the horizontal water current, U value increases.

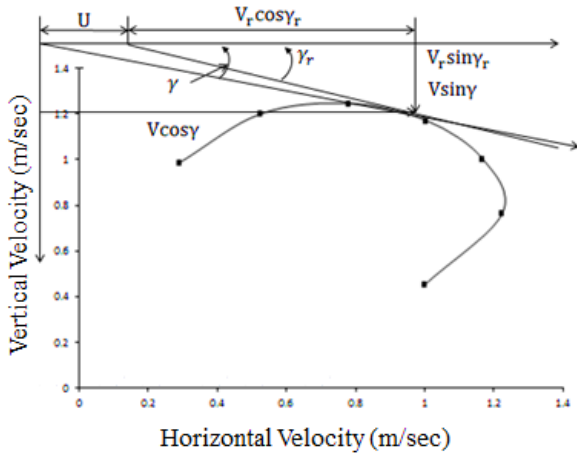

Figure 6 Glide Polar in presence of Horizontal water current (U)

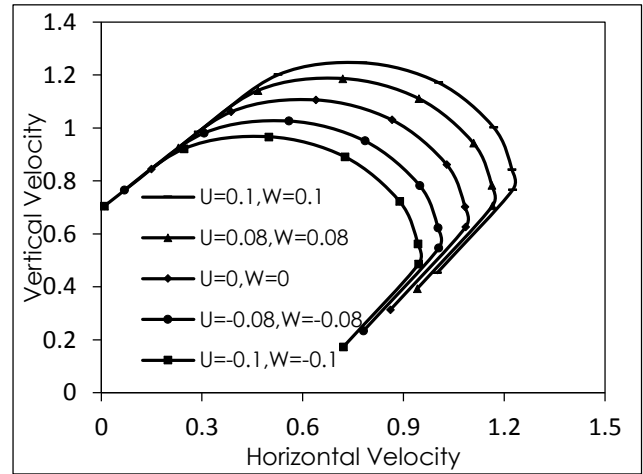

Figure 7 Horizontal velocities versus vertical velocity (Glide Polar)

Glide angle would influence the velocity, and as a result, operational range of the glider, as shown in Figure 8. The range or horizontal velocity of the glider increases with decreasing glide angle because range is directly related to the horizontal component of the glider velocity at steady state condition.

Figure 9 is shows that water current has a significant effect on the horizontal velocity of the glider. The maximum horizontal speed and range of glider will be achieved at the equilibrium glide angle of 33°. The speed of the glider has bearings on the retarding force and net buoyancy required to control the dynamics of the glider. Retarding force also depends on the wetted area and the required buoyancy actuation forces. In this study, the horizontal velocity of the glider with constant net buoyancy changes by up to 17% when the magnitude of water current varies from -0.1 to 0.1 m/s.

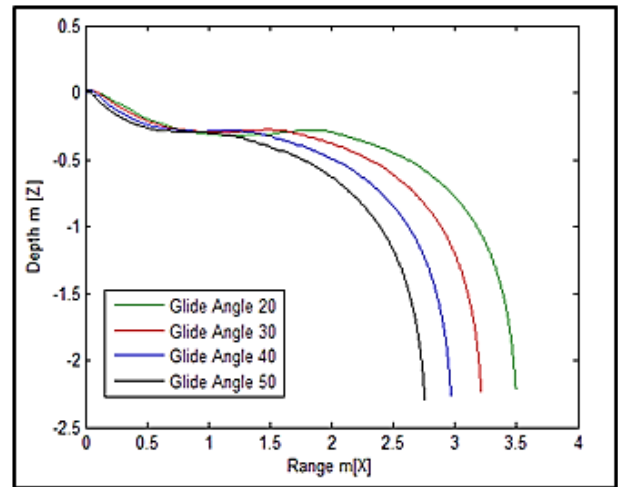

Figure 8 Depths vs range of glide at glide angle

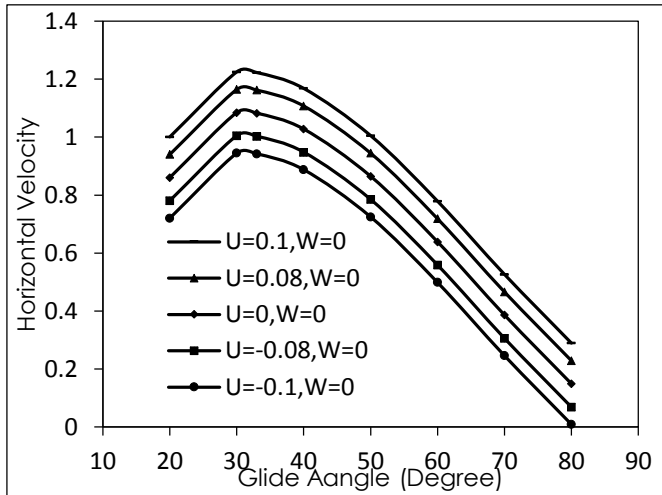

Figure 9 Glider Horizontal Velocity versus glide angle with level of Water Current

The horizontal speed of the glider is changes considerably with water current at very high glide angles, with a decrease or increase of up to 16%, depending on the direction and magnitude of the current.

The angle of attack is the angle between the velocity vector of the glider and body axis along the nose of the glider. It will be affected by the direction and magnitude of the water current. The maximum horizontal speed of the glider is achieved at equilibrium angle of attack of 60, as shown in Figure 10. However, a maximum glider horizontal velocity is not analogous to the maximum horizontal range. The range and endurance of the glider will be limited due to the pumping work required [22, 23] to regulate the velocity of the glider to achieve the desired trajectory when subjected to water currents. Figure 11 shows that the depth or sink rate of glider increases with increased net buoyancy but the range of glider decreases. The net buoyancy of the glider affects the glide angle, which affects the glider sink rate and range.

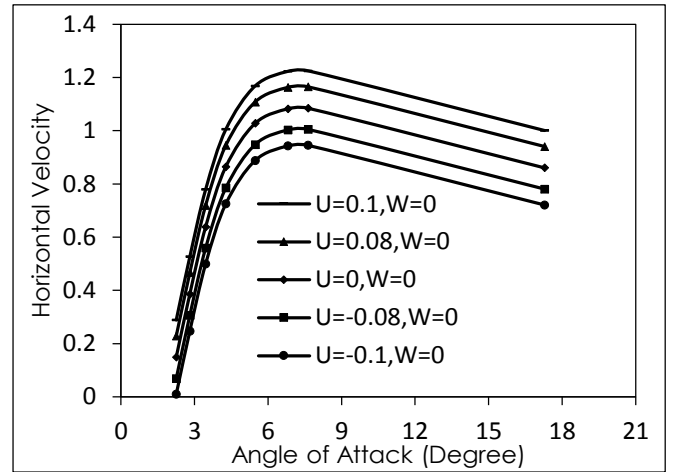

Figure 10 Horizontal Glider Velocity versus angle of attack

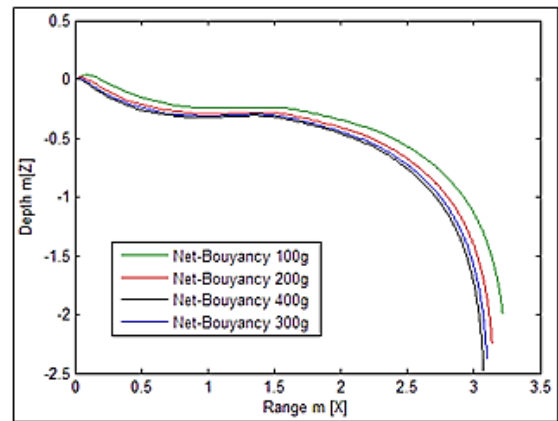

Figure 11 Depths vs range of glide at change of net-buoyancy

4.0 CONCLUSION

An underwater glider is a weak self-propelled unmanned underwater vehicle is affected by water current, specifically its speed and glide angle. The performance of a glider subjected to water currents at steady state conditions was analyzed numerically. The simulation results show that glide angle is an important factor in controlling range and gliding depth against water current. The maximum horizontal speed of glider is achieved at 33° glide angle. Beyond 33° glide angle, the sink rate increases but horizontal speed and range decreases.

Acknowledgements

Authors are thankful to Universiti Teknologi PETRONAS for providing the resources required for this work.

References

- [1] Korgen, B. J., Bodvarsson, G., and Kulm, L. 1970. Current Speeds Near The Ocean Floor West Of Oregon. *Deep Sea Research and Oceanographic Abstracts*. 353-357.
- [2] Woolsey, C. A. 2009. Optimal Underwater Glider Trajectories In Depth-Varying Currents.
- [3] Woolsey, C. 2011. Vehicle Dynamics In Currents. Technical Report VaCAS-2011-01, Virginia Center for Autonomous Systems, Virginia Tech, Blacksburg, VA.
- [4] Thomasson, P. G. and Woolsey, C. A. 2013. Vehicle Motion In Currents. *Oceanic Engineering, IEEE Journal of*. 38: 226-242.
- [5] Fan, S. and Woolsey, C. A. 2014. Dynamics Of Underwater Gliders In Currents. *Ocean Engineering*. 84: 249-258.
- [6] Lamb, H. 1945. *Hydrodynamics*. 1932. Article. 257:440-442.
- [7] Graver, J. G. 2005. Underwater Gliders: Dynamics. Control And Design. Citeseer.
- [8] Mahmoudian, N., Geisbert, J., and Woolsey, C. 2010. Approximate Analytical Turning Conditions For Underwater Gliders: Implications For Motion Control And Path Planning. *Oceanic Engineering, IEEE Journal of*. 35: 131-143.
- [9] Webb, D. C., Simonetti, P. J., and Jones, C. P. 2001. SLOCUM: An Underwater Glider Propelled By Environmental Energy. *Oceanic Engineering, IEEE Journal of*. 26: 447-452.
- [10] Sherman, J., Davis, R. E., Owens, W., and Valdes, J. 2001. The Autonomous Underwater Glider. *Oceanic Engineering, IEEE Journal of*. 26: 437-446.
- [11] Eriksen, C. C., Osse, T. J., Light, R. D., Wen, T., Lehman, T. W., Sabin, P. L., et al. 2001. Seaglider: A Long-Range Autonomous Underwater Vehicle For Oceanographic Research. *Oceanic Engineering, IEEE Journal of*. 26: 424-436.
- [12] Zhang, F., Thon, J., Thon, C., and Tan, X. 2014. Miniature Underwater Glider: Design and Experimental Results.
- [13] Zhang, F., Thon, J., Thon, C., and Tan, X. 2012. Miniature Underwater Glider: Design, Modeling, And Experimental Results. Robotics and Automation (ICRA). 2012 *IEEE International Conference on*. 4904-4910.
- [14] Lanchester, F. W. 1909. *Aerodnetics*. Constable & Company Limited.
- [15] Von Mises, R. 1959. *Theory of Flight*. Courier Corporation.
- [16] Bhatta P. and Leonard N. E. 2008. Nonlinear Gliding Stability And Control For Vehicles With Hydrodynamic Forcing. *Automatica*. 44: 1240-1250.
- [17] Graver, J. G., Bachmayer, R., Leonard, N. E., and Fratantoni, D. M. 2003. Underwater Glider Model Parameter Identification. *Proceedings of the 13th International Symposium on Unmanned Untethered Submersible Technology*.
- [18] Javaid Muhammad Yasar, O. M., Nagarajan, T., Syed Saad Azhar Ali, Ullah Barkat. 2015. Study on Wing Aspect Ratio on the Performance of a Gliding Robotic Fish. *Applied Mechanics and Materials*. 789: 248-253.
- [19] Fluent F. I. 6.1 User's Guide.
- [20] Bertram, V. 2011. *Practical Ship Hydrodynamics*. Elsevier.
- [21] Zhang, S., Yu, J., Zhang, A., and Zhang, F. 2013. Spiraling Motion Of Underwater Gliders: Modeling, Analysis, And Experimental Results. *Ocean Engineering*. 60: 1-13.
- [22] Muhammad Yasar, Javaid, Mark, Ovinis, Nagarajan; Thirumalaiswamy, Fakhruddin B M, Hashim, Adi, Maimun, and Barkat Ullah. 2015. Dynamic Motion Analysis of a Newly Developed Autonomous Underwater Glider with Rectangular and Tapered Wing. *Indian Journal of Geo-Marine Sciences*. 44(12):1928-1936.
- [23] Javaid, M. Y., Ovinis, M., Nagarajan, T., and Hashim, F. B. 2014. Underwater Gliders: A Review. *MATEC Web of Conferences*. 02020.